

---

# Molecular Pathology of Gynecologic Cancer

---

*Edited by*

Antonio Giordano, MD, PhD

Alessandro Bovicelli, MD, PhD

Robert J. Kurman, MD, PhD



 HUMANA PRESS

# MOLECULAR PATHOLOGY OF GYNECOLOGIC CANCER

# CURRENT CLINICAL ONCOLOGY

Maurie Markman, MD, SERIES EDITOR

---

- Intraperitoneal Cancer Therapy*, edited by WILLIAM C. HELM AND ROBERT EDWARDS, 2007
- Molecular Pathology of Gynecologic Cancer*, edited by ANTONIO GIORDANO, ALESSANDRO BOVICELLI, AND ROBERT KURMAN, 2007
- Colorectal Cancer: Evidence-Based Chemotherapy Strategies*, edited by LEONARD B. SALTZ, 2007
- High-Grade Gliomas: Diagnosis and Treatment*, edited by GENE H. BARNETT, 2006
- Cancer in the Spine: Comprehensive Care*, edited by ROBERT F. MCLAIN, KAI-UWE LEWANDROWSKI, MAURIE MARKMAN, RONALD M. BUKOWSKI, ROGER MACKLIS, AND EDWARD C. BENZEL, 2006
- High-Grade Gliomas: Diagnosis and Treatment*, edited by GENE H. BARNETT, 2006
- Squamous Cell Head and Neck Cancer*, edited by DAVID J. ADELSTEIN, 2005
- Hepatocellular Cancer: Diagnosis and Treatment*, edited by BRIAN I. CARR, 2005
- Biology and Management of Multiple Myeloma*, edited by JAMES R. BERENSON, 2004
- Cancer Immunotherapy at the Crossroads: How Tumors Evade Immunity and What Can Be Done*, edited by JAMES H. FINKE AND RONALD M. BUKOWSKI, 2004
- Treatment of Acute Leukemias: New Directions for Clinical Research*, edited by CHING-HON PUI, 2003
- Allogeneic Stem Cell Transplantation: Clinical Research and Practice*, edited by MARY J. LAUGHLIN AND HILLARD M. LAZARUS, 2003
- Chronic Leukemias and Lymphomas: Biology, Pathophysiology, and Clinical Management*, edited by GARY J. SCHILLER, 2003
- Colorectal Cancer: Multimodality Management*, edited by LEONARD SALTZ, 2002
- Breast Cancer: A Guide to Detection and Multidisciplinary Therapy*, edited by MICHAEL H. TOROSIAN, 2002
- Melanoma: Biologically Targeted Therapeutics*, edited by ERNEST C. BORDEN, 2002
- Cancer of the Lung: From Molecular Biology to Treatment Guidelines*, edited by ALAN B. WEITBERG, 2001
- Renal Cell Carcinoma: Molecular Biology, Immunology, and Clinical Management*, edited by RONALD M. BUKOWSKI AND ANDREW NOVICK, 2000
- Current Controversies in Bone Marrow Transplantation*, edited by BRIAN J. BOLWELL, 2000
- Regional Chemotherapy: Clinical Research and Practice*, edited by MAURIE MARKMAN, 2000
- Intraoperative Irradiation: Techniques and Results*, edited by L. L. GUNDERSON, C. G. WILLETT, L. B. HARRISON, AND F. A. CALVO, 1999

# MOLECULAR PATHOLOGY OF GYNECOLOGIC CANCER

---

*Edited by*

**ANTONIO GIORDANO, MD, PhD**

*Sbarro Institute for Cancer Research and Molecular Medicine,  
Temple University, Philadelphia, PA  
Departments of Human Pathology and Oncology,  
University of Siena, Siena, Italy*

**ALESSANDRO BOVICELLI, MD, PhD**

*Sbarro Institute for Cancer Research and Molecular Medicine,  
Temple University, Philadelphia, PA  
Department of Obstetrics and Gynecology,  
University of Bologna, Bologna, Italy*

**ROBERT J. KURMAN, MD, PhD**

*Departments of Gynecology-Obstetrics and Pathology,  
Johns Hopkins University, Baltimore MD*



**HUMANA PRESS**  
TOTOWA, NEW JERSEY

© 2007 Humana Press Inc.  
999 Riverview Drive, Suite 208  
Totowa, New Jersey 07512

**humanapress.com**

For additional copies, pricing for bulk purchases, and/or information about other Humana titles, contact Humana at the above address or at any of the following numbers: Tel: 973-256-1699; Fax: 973-256-8341; E-mail: [humana@humanapr.com](mailto:humana@humanapr.com) or visit our website at <http://humanapr.com>

All rights reserved. No part of this book may be reproduced, stored in a retrieval system, or transmitted in any form or by any means, electronic, mechanical, photocopying, microfilming, recording, or otherwise without written permission from the Publisher.

All articles, comments, opinions, conclusions, or recommendations are those of the author(s), and do not necessarily reflect the views of the publisher.

Due diligence has been taken by the publishers, editors, and authors of this book to assure the accuracy of the information published and to describe generally accepted practices. The contributors herein have carefully checked to ensure that the drug selections and dosages set forth in this text are accurate and in accord with the standards accepted at the time of publication. Notwithstanding, as new research, changes in government regulations, and knowledge from clinical experience relating to drug therapy and drug reactions constantly occurs, the reader is advised to check the product information provided by the manufacturer of each drug for any change in dosages or for additional warnings and contraindications. This is of utmost importance when the recommended drug herein is a new or infrequently used drug. It is the responsibility of the treating physician to determine dosages and treatment strategies for individual patients. Further it is the responsibility of the health care provider to ascertain the Food and Drug Administration status of each drug or device used in their clinical practice. The publisher, editors, and authors are not responsible for errors or omissions or for any consequences from the application of the information presented in this book and make no warranty, express or implied, with respect to the contents in this publication.

This publication is printed on acid-free paper.   
ANSI Z39.48-1984 (American National Standards Institute) Permanence of Paper for Printed Library Materials.

Production Editor: Rhukeya J. Hussain

Cover illustration: "Crazy Cells"  
Photo supplied by Lello Esposito ([www.lelloesposito.com](http://www.lelloesposito.com))

#### Photocopy Authorization Policy:

Authorization to photocopy items for internal or personal use, or the internal or personal use of specific clients, is granted by Humana Press Inc., provided that the base fee of US \$30.00 is paid directly to the Copyright Clearance Center at 222 Rosewood Drive, Danvers, MA 01923. For those organizations that have been granted a photocopy license from the CCC, a separate system of payment has been arranged and is acceptable to Humana Press Inc. The fee code for users of the Transactional Reporting Service is: [978-1-58829-453-1 • 1-58829-453-6/07 \$30.00].

Printed in the United States of America. 10 9 8 7 6 5 4 3 2 1  
eISBN-13: 978-1-59745-346-2  
eISBN-10: 1-59745-346-3

#### Library of Congress Cataloging-in-Publication Data

Molecular pathology of gynecologic cancer / edited by Antonio Giordano, Alessandro Bovicelli, Robert J. Kurman.  
p. : cm. -- (Current clinical oncology)

Includes bibliographical references and index.

ISBN-13: 978-1-58829-453-1 (alk. paper)

ISBN-10: 1-58829-453-6 (alk. paper)

1. Generative organs, Female--Cancer--Molecular aspects. I. Giordano, Antonio, MD. II. Bovicelli, Alessandro. III. Kurman, Robert J. IV. Series: Current clinical oncology (Totowa, N.J.)

[DNLM: 1. Genital Neoplasms, Female--genetics. 2. Genital Neoplasms, Female--etiology. 3. Genital Neoplasms, Female--physiopathology. 4. Mutation. WP 145 M718 2007]

RC280.G5M65 2007

616.99'465--dc22

2006039396

*In Memory of Carla*

---

# Preface

---

The study of molecular oncology has unequivocally demonstrated that tumors arise because cells accumulate a series of genetic alterations that impedes the correct transfer of the information necessary for carrying out the processes of replication, differentiation, and cell death. Generally, in order for tumors to arise, it is necessary that cells undergo multiple genetic alterations, and epidemiological studies suggest that numerous decades are necessary for a cell to accumulate all the mutations necessary for the development of the neoplasia. The multitude of genetic errors and their differing relationship in the single transformed cells explain the diversity of tumoral diseases and suggest the opportunity to identify specific therapies for individual tumors.

The study of molecular oncology has resulted in knowledge of the genetic errors that impede the correct transfer of information. This has enabled the researcher to identify the ideal targets to hit so that tumoral cells are selectively destroyed and, as a consequence, to suggest the way to put a successful therapeutic strategy into practice.

As a result of this knowledge and the great commitment of the experimental and clinical researchers, great advances have been made in selectively hitting tumoral targets with so-called “intelligent” drugs .

In order to eradicate cancer in its entirety, however, further efforts are needed, because there are multiple incorrect messages in tumors, many of which are still unknown.

Identifying and cataloging the communication errors and the incorrect messages for each type of tumor will require many years of study and research.

Fortunately, with the bad news that cancer is generated by a series of genetic alterations, the study of molecular oncology has also furnished some good news:

1. The communication errors at the basis of the formation of tumors substantially generate incorrect messages through signals (biochemical mechanisms) common to many cells;
2. The new technology developed following knowledge of genomics, proteomics, and bioimages furnishes the means to shorten the time necessary for identifying the errors of communication.

Therefore, a problem such as the multiplicity of targets cannot only be reduced to an accessible number of targets but can also become an opportunity.

The common intention of the authors of *Molecular Pathology of Gynecologic Cancer* is to shed light on all the most recent acquisitions in oncologic gynecology obtained using an innovative multidisciplinary approach practiced by clinicians and experimental researchers who are in constant partnership.

**Antonio Giordano, MD, PhD**  
**Giovan Giacomo Giordano, MD, PhD**  
**Alessandro Bovicelli, MD, PhD**  
**Robert J. Kurman, MD, PhD**

---

# Contents

---

Preface .....	vii
Contributors .....	xi
Color Plates .....	xiii
<b>I INTRODUCTION</b>	
1 The Cell Cycle and the Molecular Biology of Cancer .....	3
<i>Giuseppina D'Andrilli, Alessandro Bovicelli, and Antonio Giordano</i>	
<b>II OVARIAN CANCER</b>	
2 Ovarian Serous Carcinogenesis: A Proposed Model .....	17
<i>Ie-Ming Shih and Robert J. Kurman</i>	
3 Molecular Markers in Epithelial Ovarian Cancer .....	29
<i>Pat J. Morin</i>	
<b>III ENDOMETRIAL CANCER</b>	
4 Introduction to Endometrial Cancer .....	51
<i>Richard J. Zaino</i>	
5 Endometrial Carcinogenesis: <i>An Integrated, Molecular, Histological,</i> <i>and Functional Model of a Dualistic Disease</i> .....	73
<i>George L. Mutter</i>	
6 Endometrial Carcinoma—Molecular Genetic Aspects .....	91
<i>Lora Hedrick Ellenson</i>	
<b>IV CERVICAL CANCER</b>	
7 Natural History of HPV Infection in Adolescents and Relationship to Cervical Cancer .....	103
<i>Anna-Barbara Moscicki</i>	
8 Molecular Genetics of Cervical Cancer .....	113
<i>Valeria Masciullo and Antonio Giordano</i>	
9 Prevention and Treatment of Cervical Cancer by Vaccination .....	125
<i>Hannah H. Alphas, T-C Wu, and Richard B. S. Roden</i>	
<b>V GESTATIONAL TROPHOBLASTIC DISEASE</b>	
10 Pathogenesis of Gestational Trophoblastic Lesions .....	157
<i>Ie-Ming Shih and Robert J. Kurman</i>	
<b>VI HEREDITARY ISSUES IN GYNECOLOGICAL CANCER</b>	
11 Hereditary Issues in Ovarian Cancer .....	169
<i>Christina S. Chu and Stephen C. Rubin</i>	



---

12	Hereditary Factors in Endometrial Cancer .....	195
	<i>Henry T. Lynch, Murray Joseph Casey, Joseph A. Knezetic, Trudy G. Shaw, Jane F. Lynch, and Chhanda Bewtra</i>	
VII	THE MULTIDISCIPLINARY THERAPEUTIC APPROACH TO GYNECOLOGICAL CANCER IN THE NEW MILLENIUM	
13	The Holistic Approach to Female Cancer Patients .....	219
	<i>Alessandro Bovicelli, Pier Paolo Claudio, and Antonio Giordano</i>	
Index	.....	223

---

# Contributors

---

- HANNAH H. ALPHS, BS • *Department of Pathology, Johns Hopkins University School of Medicine, Baltimore, MD*
- Chhanda Bewtra, MD • *Department of Pathology, Creighton University Medical Center, Omaha, NE*
- ALESSANDRO BOVICELLI, MD, PhD • *Sbarro Institute for Cancer Research and Molecular Medicine, Temple University, Philadelphia, PA and Department of Obstetrics and Gynecology, University of Bologna, Bologna, Italy*
- MURRAY JOSEPH CASEY, MD • *Department of Obstetrics and Gynecology, Creighton University School of Medicine, Omaha, NE*
- CHRISTINA S. CHU, MD • *Division of Gynecologic Oncology, Department of Obstetrics and Gynecology, University of Pennsylvania Medical Center, Philadelphia, PA*
- PIER PAOLO CLAUDIO, MD, PhD • *Sbarro Institute for Cancer Research and Molecular Medicine, Temple University, Philadelphia, PA*
- GIUSEPPINA D'ANDRILLI, MD, PhD • *Sbarro Institute for Cancer Research and Molecular Medicine, Temple University, Philadelphia, PA*
- LORA HEDRICK ELLENSON, MD • *Department of Pathology and Laboratory Medicine, Weill Medical College of Cornell University, New York, NY*
- ANTONIO GIORDANO, MD, PhD • *Sbarro Institute for Cancer Research and Molecular Medicine, Temple University, Philadelphia, PA and Departments of Human Pathology and Oncology, University of Siena, Siena, Italy*
- GIOVAN GIACOMO GIORDANO, MD, PhD • *Sbarro Institute for Cancer Research and Molecular Medicine, Temple University, Philadelphia, PA*
- Joseph A. Knezetic, PhD • *Department of Preventive Medicine, Creighton University School of Medicine, Omaha, NE*
- ROBERT J. KURMAN, MD, PhD • *Departments of Gynecology-Obstetrics and Pathology, Johns Hopkins University, Baltimore MD*
- HENRY T. LYNCH, MD • *Medical Oncology and Genetic Consultation, Department of Preventive Medicine, Creighton University School of Medicine, Omaha, NE*
- Jane F. Lynch, BSN • *Department of Preventive Medicine, Creighton University School of Medicine, Omaha, NE*
- VALERIA MASCIULLO, MD, PhD • *Sbarro Institute for Cancer Research and Molecular Medicine, Temple University, Philadelphia, PA*
- PAT J. MORIN, PhD • *Laboratory of Cellular and Molecular Biology, National Institute on Aging, Baltimore, MD*
- ANNA-BARBARA MOSCICKI, MD • *Division of Adolescent Medicine, Department of Pediatrics, School of Medicine, University of California at San Francisco, San Francisco, CA*

GEORGE L. MUTTER, MD • *Department of Pathology, Brigham and Women's Hospital, Boston, MA*

RICHARD B. S. RODEN, PhD • *Departments of Pathology, Gynecology-Obstetrics, and Oncology, Johns Hopkins University School of Medicine, Baltimore, MD*

STEPHEN C. RUBIN, MD • *Division of Gynecologic Oncology, Department of Obstetrics and Gynecology, University of Pennsylvania Medical Center, Philadelphia, PA*

Trudy G. Shaw, MA • *Medical Oncology and Genetic Consultation, Creighton University School of Medicine, School of Medicine, Omaha, NE*

IE-MING SHIH, MD, PhD • *Department of Pathology, Johns Hopkins University School of Medicine, Baltimore, MD*

T-C WU, MD, PhD • *Departments of Pathology, Oncology, Obstetrics and Gynecology, and Molecular Microbiology and Immunology, The Johns Hopkins Medical Institutions, Baltimore, MD*

RICHARD J. ZAINO, MD • *Department of Pathology, Milton S. Hershey Medical Center of Pennsylvania State University, Hershey, PA*

---

# Color Plates

---

Color plates follow p. 50

- COLOR PLATE 1 A schematic model of the normal mammalian cell cycle. (Chapter 1, Fig. 1; *see* full caption on p. 4 and discussion on p. 3.)
- COLOR PLATE 2 HPV genome organization. (Chapter 9, Fig. 1; *see* full caption on p. 128 and discussion on p. 127.)
- COLOR PLATE 3 HPV structure. (Chapter 9, Fig. 2; *see* full caption on p. 128 and discussion on p. 127.)
- COLOR PLATE 4 HPV life cycle. (Chapter 9, Fig. 3; *see* full caption on p. 131 and discussion on p. 130.)
- COLOR PLATE 5 Examples of abnormal cervical cytopathology. (Chapter 9, Fig. 4; *see* full caption on p. 132 and discussion on p. 131.)
- COLOR PLATE 6 Summary of strategies to prevent and treat cervical cancer. (Chapter 9, Fig. 6; *see* discussion on p. 147.)

# I

---

## INTRODUCTION

---

# 1

---

## The Cell Cycle and the Molecular Biology of Cancer

---

*Giuseppina D'Andrilli, MD, PhD,  
Alessandro Bovicelli, MD, PhD,  
and Antonio Giordano, MD, PhD,*

### *CONTENTS*

INTRODUCTION  
FUTURE DIRECTIONS  
REFERENCES

---

## 1. INTRODUCTION

Human malignant tumors are characterized by abnormal proliferation resulting from alterations in cell-cycle regulatory mechanisms. The regulatory pathways controlling cell-cycle phases include several oncogenes and tumor suppressor genes, which display a range of abnormalities with potential usefulness as markers of evolution or treatment response in cancer. This chapter summarizes the current knowledge about these aberrations in malignant transformation.

### *1.1. Cell Cycle: The Importance of its Control*

Cancer is frequently considered to be a disease of the cell cycle. Alterations in different families of cell-cycle regulators cooperate in tumor development. Molecular analysis of human tumors has shown that cell-cycle regulators are frequently mutated in human neoplasms, which underscores how important the maintenance of cell cycle commitment is in the prevention of human cancer. Mammalian cell division is precisely regulated in a timely manner by a family of protein kinases, the cyclin-dependent kinases (CDKs), which is a group of serine/threonine kinases that form active heterodimeric complexes following binding to cyclins, their regulatory subunits. Regulation of CDK activity occurs at multiple levels, including cyclin synthesis and degradation, phosphorylation and dephosphorylation, CDK inhibitor (CKI) protein synthesis, binding and degradation, and subcellular localization. Orderly progression through the cell cycle involves coordinated activation of the CDK protein by binding to the cyclin partner. A succession of kinases (CDK4, CDK6, CDK2, and CDC2) are

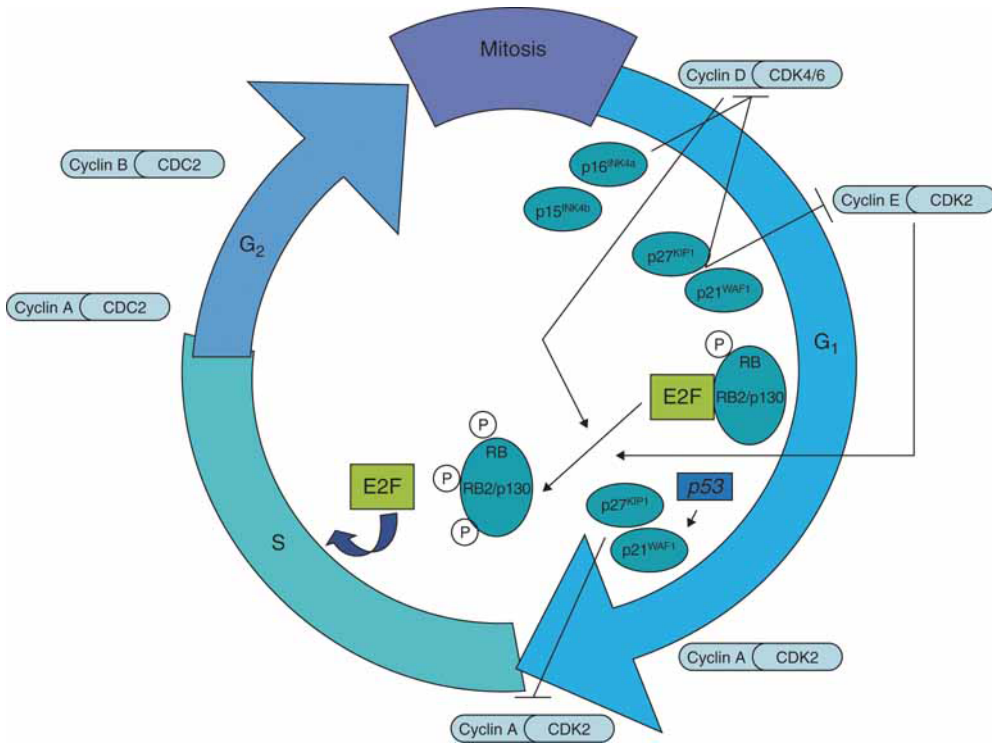

**Fig. 1 (Color Plate 1, following p. 50).** A schematic model of the normal mammalian cell cycle.  $G_1$  to S transition in normal cells requires phosphorylation of the retinoblastoma proteins by CDKs, which causes the release of E2F transcription factors controlling various genes required for DNA synthesis during S phase. The CKIs  $p21^{WAF1}$  and  $p27^{KIP1}$  act by binding to cyclin–CDK2 complexes to inhibit their catalytic activity and induce cell cycle arrest, whereas  $p16^{INK4a}$  inhibits CDK4/6. Wild-type  $p53$  activates the transcription of  $p21$  gene.

expressed along with a succession of cyclins (D, E, A, and B) as cells go from  $G_1$  to S and then to  $G_2$  and finally, to M phase (Fig. 1; see Color Plate 1, following p. 50).

Different CDK–cyclin complexes operate during different phases of the cell cycle. Active CDK–cyclin complexes phosphorylate target substrates, including members of the “pocket protein” family (pRb, p107, and pRb2/p130) (1,2).  $G_1/S$  transition in normal cells requires phosphorylation of the retinoblastoma protein pRb and the related proteins pRb2/p130 and p107 by CDKs, which causes the release of E2F transcription factors controlling various genes required for DNA synthesis and cell-cycle control.

Endogenous inhibition of CDKs is also caused by two families of regulatory proteins induced under mitogenic stimuli: (1) the INK4 family, consisting of  $p16^{INK4a}$ ,  $p15^{INK4b}$ ,  $p18^{INK4c}$ , and  $p19^{INK4d}$ , which specifically inhibit CDK4 and CDK6 (3) and (2) the CIP/KIP family including  $p21^{CIP1/WAF1}$ ,  $p27^{KIP1}$ , and  $p57^{KIP2}$ , which cause a broader range of inhibition and act in a concentration-dependent manner (4). All CKIs cause  $G_1$  arrest when overexpressed in cells by association and inhibition of the CDKs. INK4 proteins dissociate cyclin D/CDK complexes and redistribute the CIP/KIP proteins to CDK2, producing a double inhibition. At low concentrations, CIP/KIP family proteins enhance CDK4 association with cyclin D, increasing the activity of the complex. Whereas at high concentrations they inhibit kinase activity, presumably by increasing the stoichiometry in the CDK complexes (5). The best-studied events of the

cell cycle are the  $G_1$  phase preceding the DNA synthesis (S) phase and the mechanism that drives the cell across the restriction (R) point in late  $G_1$ , which is crucial for the cell's destiny toward division, differentiation, senescence, or apoptosis. Several studies suggest that traversal of the R point within the  $G_1$  phase is the key event in cell-cycle regulation, and that the rest of cell-cycle progression occurs almost automatically once the R point has been overcome (6). Several proteins can inhibit the cell cycle in  $G_1$  phase; if DNA damage occurs, p53 accumulates in the cell and induces the p21-mediated inhibition of cyclin D/CDK. The frequent loss of  $G_1$  regulation in human cancer has revealed targets for possible therapeutic intervention. D-type cyclins are transcribed in the  $G_1$  phase of the cell cycle. The isoforms D1, D2, and D3 are functionally equivalent, and are expressed in a tissue-specific manner. CDK4 and CDK6 are activated by D cyclins to phosphorylate the retinoblastoma protein pRb, a known cell proliferation regulator. The members of the INK4 family exert their inhibitory activity by binding to the CDK4 and CDK6 kinases and preventing their association with D-type cyclins.

Genetic analysis of human tumors has revealed that some of the molecules most often altered in cancer are those involved in the control of the  $G_1/S$  transition of the cell cycle, a time when cells become committed to a new round of cell division. During the  $G_1/S$  transition, the cyclin E/CDK2 and cyclin D/CDK4 complexes promote progression and are each inhibited by the associated CKI p27<sup>kip1</sup>. The transition to S phase is triggered by the activation of the cyclin D/CDK complex, which phosphorylates pRb.

In contrast to  $G_1$  regulators, less is known about the genes, which regulate the S,  $G_2$ , and M phases of the cell-cycle like cyclin A- and cyclin B-kinase complexes and their inhibitors. The significance of cell cycle regulatory genes in carcinogenesis is underlined by the fact that most of them have been identified as proto-oncogenes or tumor suppressor genes.

In S phase, phosphorylation of components of the DNA replication machinery by cyclin A-CDK is believed to be important for initiation of DNA replication and to restrict the initiation to only once per cell cycle. Transition from  $G_2$  to M phase involves destruction of cyclin A and ascendancy of cyclin B. The protein phosphatase CDC25 removes inhibitory phosphates from CDK1/cyclin B complexes. During the normal cell cycle, negative regulation by phosphorylation of cyclin B/CDC2 prevents premature mitotic entry before the completion of S phase.

### ***1.2. Alterations in the Cell Cycle Leading to Malignant Transformation***

The knowledge about the molecular mechanisms required for tumor formation has greatly increased during the last 40 years. Key molecular mechanisms required for malignant transformation have been identified. Tumor growth is a dynamic process in which it is difficult to identify a unique event that caused the process. It is well-established that numerous events together contributed to the acquisition of the malignant phenotype. It is commonly accepted that a thorough understanding of the molecular mechanisms that lead to uncontrolled proliferation of cancer cells will allow the identification of targets that can be therapeutically manipulated to arrest or kill tumor cells. For many years, considerable effort has been made to understand the machinery that controls normal cell cycles, thereby aiding the identification of molecules or processes altered in tumor cell cycles. Alterations in the machinery that controls the decision to progress from a resting state into the cell cycle (the so-called  $G_0/G_1$  transition) or to progress from  $G_1$  into S phase are found in virtually all tumor cells.



### 1.3. Alterations of the $G_1$ to S Regulatory Machinery in Cancer

#### 1.3.1. CYCLIN E

Cyclin E–CDK2 has long been considered an essential and master regulator of progression through  $G_1$  phase of the cell cycle. Cyclin E–CDK2 activity is the highest in  $G_1$ /S cells and the lowest in quiescent cells (7–9). This periodicity results from many factors including transcriptional and post-transcriptional control of cyclin E abundance, the binding of CIP/KIP CKIs (10), and modification of CDK2 activity by inhibitory and activating phosphorylations. These multiple layers of control ensure that cyclin E activity is tightly regulated during normal cell cycles. In contrast, cyclin E–CDK2 is often deregulated in cancer cells, and this likely contributes to the development of cancer. Many cancers overexpress cyclin E protein or mRNA including carcinomas (breast, lung, cervix, endometrium, gastrointestinal tract), lymphoma, leukemia, sarcomas, and adrenocortical tumors (11–20). Several mechanisms deregulate cyclin E expression in tumors. A large number of oncogenes function within the mitogenic signal transduction pathways that regulate the pRb pathway, and oncogenic mutations within these pathways may increase cyclin E abundance through increased E2F activity. The most common means of activating cyclin E expression in cancers might thus involve mutations in regulatory pathways, rather than within cyclin E itself.

#### 1.3.2. CYCLIN D1

The improper formation of cyclin D1 complexes with CDK4/6 or other aberrant hyperactivation of these complexes could act equivalently to pRb loss to render a cell insensitive to a need for mitogenic signaling. Such aberrant CDK activation or loss of pRb has obvious implications for cancer cell generation and, indeed, pRb loss or hyperactivation of CDK4 and/or CDK6 is found in most human tumor cells. Hyperactivation of CDK4 and CDK6 can be achieved through deregulated expression of D-type cyclins, loss of p16<sup>INK4a</sup> or other members of the INK4 family more commonly involved in differentiation or transforming growth factor-signaling (21), or mutation-based insensitivity to the inhibitory effects of p16<sup>INK4a</sup>. Hence, every element of the core pRb pathway (p16<sup>INK4a</sup>, D-type cyclins, CDK4/6, and pRb itself) represents a potential oncogene or a tumor suppressor.

Molecular analysis of human cancers strongly support this notion. For instance, amplification or rearrangement of the *cyclin D1* gene located on chromosome 11q13 as well as overexpression of cyclin D1 protein has been described in a wide spectrum of human cancers, such as squamous cell carcinomas of head and neck, esophagus, tongue and larynx, carcinomas of uterine cervix, astrocytomas, nonsmall-cell lung cancers, soft-tissue sarcomas, and others (22–27). The best-documented of these alterations is a frequent involvement of cyclin D1 in pathogenesis of human breast cancer. Thus, approx 15–20% of human mammary carcinomas contain amplification of the *cyclin D1* gene (28–30), whereas cyclin D1 protein is overexpressed in more than 50% of human breast cancers (31–35). Cyclin D1 overexpression is seen at the earliest stages of breast cancer progression, such as ductal carcinoma *in situ*, but not in premalignant lesions (such as atypical ductal hyperplasia). Hence, overexpression of cyclin D1 can serve as a marker of malignant transformation of mammary epithelial cells (36). Once cyclin D1 overexpression is acquired by the tumor cells, it is maintained at the same level throughout breast cancer progression from ductal carcinoma *in situ* to invasive carcinoma and is preserved even in metastatic lesions (31,35).

### 1.3.3. CYCLIN D2 AND CYCLIN D3

*Cyclin D2* and *D3* genes are also amplified and the encoded proteins are overexpressed in many human cancers. *Cyclin D2* is involved in B-cell lymphocytic leukemias and lymphoplasmacytic lymphomas (37), chronic lymphocytic leukemias (38) as well as in testicular and ovarian germ cell tumors. *Cyclin D3* overexpression has been found in glioblastomas, renal cell carcinomas, pancreatic adenocarcinomas, and several B-cell malignancies, such as diffuse large B-cell lymphomas or multiple myelomas (39–43).

### 1.3.4. CDK4

Similarly, overexpression of CDK4 is found (often as consequence of gene amplification) in breast cancers (44), in gliomas, glioblastomas multiforme, sarcomas, and urinary bladder cancers (45–49). Moreover, in several human malignancies, the kinase activity of CDK4 is hyperactivated because of the loss, mutation, or silencing of the gene encoding the CDK4 inhibitor, p16<sup>INK4a</sup> (50–54). Yet, another set of tumors, including retinoblastoma, osteosarcoma, small-cell lung carcinoma, and bladder carcinoma, is associated with the loss of the pRb protein (55). Cyclin A is a particularly interesting member of the cyclin family because it can activate two different CDKs and functions in both S phase and mitosis. In mitosis, the precise role of cyclin A is still obscure, but it might contribute to the control of cyclin B stability. Consistent with its role as a key cell-cycle regulator, expression of cyclin A is found to be elevated in a variety of tumors.

### 1.3.5. ALTERATIONS OF THE CKIs

CKIs are negative regulators of the cell cycle. Thus, perturbation in their activity results in severe dysregulation of cell proliferation and failure to suppress tumor growth (56). The INK4 CKIs are lost through mutation, deletion, and/or promoter methylation in a variety of human neoplasms and in this sense are true tumor suppressor genes (21). On the contrary, the CIP/KIP CKI p27<sup>kip1</sup> does not fit the classic tumor suppressor paradigm in humans, as mutations in the *p27<sup>kip1</sup>* gene in human tumors are extremely rare (57). However, p27<sup>kip1</sup> has been defined “tumor suppressor protein” because inactivation of its function has been implicated in the development of human tumor (58).

Two different mechanisms have been implicated in *p27<sup>kip1</sup>* inactivation during the process of human carcinogenesis: downregulation of its expression and exclusion from the nuclear compartment. A drastic reduction in the level of p27<sup>kip1</sup> protein (or even a complete loss) is observed in approx 50% of all types of human cancer (59). Reduced p27<sup>kip1</sup> expression has been associated with the development of human epithelial tumors originating from the majority of human organs, including lung (60), breast (61), colon (62), ovary (63), esophagus (64), thyroid (65), and prostate (66). Loss of p27<sup>kip1</sup> expression is detected also in a subset of malignancies originated from the central nervous system (67) and from the lymphoid tissue (68).

In most human tumors the loss of p27<sup>kip1</sup> protein results from altered proteasome-mediated degradation (62). Fast, specific, and timely proteolysis of cell-cycle regulators by the ubiquitin–proteasome system represents an important mechanism, which ensures proper progression through the cell division in a unidirectional and irreversible manner (69). A finding that is crucial for its clinical implications is that low or absent p27<sup>kip1</sup> expression represents an important marker of disease progression in a number of tumor types (60,63,66).

Cytoplasmic sequestration of p27<sup>kip1</sup> in tumors has been identified only recently as a mechanism, whereby cancer cells promote cancerogenesis in humans. Displacement of p27<sup>kip1</sup> into the cytoplasm has been shown to contribute to the anchorage-independent growth of human transformed fibroblasts. It is performed by maintaining high cyclin–CDK activity in the nucleus (70), and the increased proliferation associated with the loss of the tuberous sclerosis complex-2 gene product (tuberin), a GTPase-activating protein for Rap1a and Rab5 GTPases (71).

#### ***1.4. p53 Pathway in Cancer***

Cells contain numerous pathways designed to protect them from the genomic instability or toxicity that can result when their DNA is damaged. The p53 tumor suppressor is particularly important for regulating passage through G<sub>1</sub> phase of the cell cycle, whereas other checkpoint regulators are important for arrest in S and G<sub>2</sub> phase. The phase of the cell cycle in which the cells arrest depends on their p53 status. Cells with wild-type p53 arrest predominantly in the G<sub>1</sub> phase, whereas cells with mutant p53 fail to arrest in G<sub>1</sub>, but rather accumulate in the S and G<sub>2</sub> phases. Once repair is complete, cells might recover, proliferate, and divide. Premature progression through the cell cycle can be lethal.

Wild-type p53 can prevent abrogation of arrest by elevating levels of p21<sup>waf1</sup> and by decreasing levels of cyclins A and B. p21<sup>waf1</sup> regulates cyclin E/CDK2 and cyclin A/CDK2 complexes, both of which phosphorylate pRb. Thus, it contributes to the transition into the S phase and cell-cycle progression, even in the absence of growth signals.

The accumulation of p21<sup>waf1</sup> followed by inhibition of cyclin E/CDK2 and cyclin A/CDK2 complexes blocks the progression from G<sub>1</sub> to S phase (72). Moreover, p21<sup>waf1</sup> is also involved in the apoptotic process by increasing the phosphorylation and inactivation of pRb. During tumorigenesis, tumor cells frequently lose checkpoint controls, which causes the development of the tumor. However, these defects also represent an Achilles heel that can be targeted to improve current therapeutic strategies. Virtually, all human tumors deregulate either pRb or p53 pathways, and often both simultaneously. The importance of these pathways in cellular growth control is underscored by the observation that members of these pathways are found mutated in all human cancers. For example, many studies have pointed out the aberrant expression and prognostic significance of individual proteins in either the pRb (particularly cyclin D1, p16<sup>INK4a</sup>, and pRb) or the p53 (p53 and p21<sup>waf1</sup>) pathways in nonsmall-cell lung cancer (73).

#### ***1.5. pRb Pathway in Cancer***

The protein product of the retinoblastoma gene, pRb, and the related p107 and p130 proteins regulate transitions between cell proliferation and terminal differentiation. A common relevant biological activity shared by the three members of this family is the ability to negatively control the cell cycle (74–77). In fact, they negatively modulate the transition between the G<sub>1</sub> and S phases, using mechanisms mostly related to inactivation of transcription factors, such as those of the E2F family, that promote the cell entrance into the S phase. pRb, p107, and p130 all bind to E2F, a transcription factor that regulates the expression of numerous genes needed for cell-cycle entry and DNA synthesis (78). pRb associates with each member of the E2F family, except E2F5 and E2F6, whereas p107 binds E2F4 exclusively, and p130 binds both E2F4 and E2F5 (79),

switching from E2F5 in  $G_0$  to E2F4 complexes as the cell re-enters the  $G_1$  phase (80,81). Complex formation between E2F and pRb families is cell-cycle-dependent: CDKs phosphorylate the pRb family in late  $G_1$ , liberating free E2F (82,83). The three members are active in complexes at different time of the cell cycle: pRb2/p130 is primarily active in arrested  $G_0$  or differentiated cells (84), active pRb is found in quiescent and differentiated cells as well as in mid to late  $G_1$ , and p107 complexes are the most abundant in cycling cells, in  $G_1/S$  and S phase complexes (81). The full-length pRB protein contains 16 consensus CDK-phosphorylation sites. Phosphorylation at specific sites inhibits the binding of pRB to cellular proteins, thereby disrupting the antiproliferative activity of RB (85,86). Therefore, overexpression of proteins which causes excessive or deregulated phosphorylation of pRB is a common event in human tumors (10,87,88). The pRb-, p107-, and pRb2/p130–E2F complexes can each be disrupted by viral oncoproteins (E1A, SV40, and E7), resulting in the deregulation of E2F transcriptional activity (89,90).

p107 is mostly predominant during the late  $G_1$  phase through  $G_2/M$  and its expression is strictly regulated by its E2F dependent promoter. In contrast to p107, lack of pRb2/p130 expression has been observed in several different tumor types supporting its bonafide tumor suppressor function. During the last 10 years, a large number of studies have examined the diagnostic and prognostic significance of pRb expression in various tumors. Almost all studies report decreased pRb expression in a broad spectrum of tumors. pRb is lower in more aggressive myelogenous leukemia (91–93), as well as in nonsmall-cell lung carcinoma (94,95), in papillary thyroid carcinoma (96), in bladder (97), prostate (98,99) and ovarian (100) carcinomas, malignant astrocytoma (101), non-Hodgkin's lymphoma (102), and other types of cancer. The loss or decreased expression of pRb2/p130 was found in lung carcinomas (95,103), endometrial cancer (104–106), choroidal melanoma (107), non-Hodgkin lymphoma (108), vulvar cancer (109), prostatic (110) and ovarian carcinomas (111).

### ***1.6. Alterations of the $G_2$ to M Regulatory Machinery in Cancer***

The  $G_2/M$  checkpoint prevents cells from initiating mitosis when they experience DNA damage during  $G_2$ , or when they progress into  $G_2$  with some unrepaired damage inflicted during previous S or  $G_1$  phases (112,113). The accumulation of cells in  $G_2$  might also reflect a contribution of the so-called DNA-replication checkpoint that may detect some of the persistent DNA lesions from the previous S phase as being inappropriately or not fully replicated DNA.

The critical target of the  $G_2/M$  checkpoint is the mitosis-promoting activity of the cyclin B/CDK1 kinase. Its activation after various stresses is inhibited by ataxia telangiectasia mutated (ATM)/ATM and Rad3-related (ATR), Checkpoint kinase CHK1/CHK2, and/or p38-kinase-mediated subcellular sequestration, degradation, and/or inhibition of the CDC25 family of phosphatases that normally activate CDK1 at the  $G_2/M$  boundary (113–115). In addition, other upstream regulators of CDC25C and/or cyclin B/CDK1, such as the Polo-like kinases PLK3 and PLK1 seem to be targeted by DNA-damage-induced mechanisms (113).

The maintenance phase of the  $G_2/M$  checkpoint probably partly depends on the transcriptional programs regulated by *BRCA1* and *p53*, leading to the upregulation of cell-cycle inhibitors such as the CKI p21<sup>waf1</sup>, GADD45a (growth arrest and DNA-damage-inducible 45- $\alpha$ ), and 14–3–3 sigma proteins (113,116). The fact that even tumors

defective in other checkpoints, such as those with mutant *p53*, tend to selectively accumulate in G<sub>2</sub> after DNA damage, indicates that *p53*-independent mechanisms are sufficient to sustain the G<sub>2</sub>/M arrest. At the same time, this phenomenon has inspired efforts to interfere with the G<sub>2</sub>/M checkpoint as a potential strategy to sensitize cancer cells, which are deficient in their G<sub>1</sub>/S checkpoint pathways, to radiation- or drug-induced DNA damage (117).

## 2. FUTURE DIRECTIONS

Understanding the complex molecular mechanism that regulates cell-cycle progression and is involved in tumor development and progression, still remains the major goal in cancer research. Indeed, an increased knowledge of the alteration in both pRb and *p53* pathways will be useful to design appropriate anticancer treatments. A better knowledge of the epigenetic mechanism affecting key regulators of cell cycle could open up a new dimension to manage a variety of human cancers.

Animal models and human-cancer-susceptibility syndromes will continue to teach us about the physiological roles of the genes and pathways involved in DNA-damage responses. Many questions remain, such as how the cross-talk between the signaling pathways discussed here, and the processes of DNA repair and apoptosis operate. As these pathways seem to be major determinants of cellular responses to the types of cytotoxic agent that are used to treat tumors, these insights might teach new ways to treat tumors more effectively. Similarly, because these response pathways seem to be major protectors from cancer development, the study of these pathways could lead to effective and new approaches to the reduction of cancer development. In addition to the prevention of cancer and more effective treatment of malignancies, insights into the mechanisms involved in these response pathways may even shed light on the processes of aging and senescence.

## REFERENCES

1. Stiegler P, Kasten M, Giordano A. The RB family of cell cycle regulatory factors. *J Cell Biochem Suppl* 1998; 30–31: 30–36.
2. Paggi MG, Giordano A. Who is the boss in the retinoblastoma family? The point of view of Rb2/p130, the little brother. *Cancer Res* 2001; 61(12): 4651–4654.
3. Carnero A, Hannon GJ. The INK4 family of CDK inhibitors. *Curr Top Microbiol Immunol* 1998; 227: 43–55.
4. Hengst L, Reed SI. Inhibitors of the Cip/Kip family. *Curr Top Microbiol Immunol* 1998; 227: 25–41.
5. Sherr CJ, Roberts JM. CDK inhibitors: positive and negative regulators of G1-phase progression. *Genes Dev* 1999; 13(12): 1501–1512.
6. Lundberg AS, Weinberg RA. Control of the cell cycle and apoptosis. *Eur J Cancer* 1999; 35(4): 531–539.
7. Dulic V, Lees E, Reed SI. Association of human cyclin E with a periodic G1-S phase protein kinase. *Science* 1992; 257(5078): 1958–1961.
8. Koff A, Giordano A, Desai D, et al. Formation and activation of a cyclin E-cdk2 complex during the G1 phase of the human cell cycle. *Science* 1992; 257(5077): 1689–1694.
9. Ekholm SV, Zickert P, Reed SI, et al. Accumulation of cyclin E is not a prerequisite for passage through the restriction point. *Mol Cell Biol* 2001; 21(9): 3256–3265.
10. Sherr CJ, Roberts JM. Inhibitors of mammalian G1 cyclin-dependent kinases. *Genes Dev* 1995; 9(10): 1149–1163.
11. Wolowiec D, Mekki Y, Ffrench P, et al. Differential expression of cell proliferation regulatory proteins in B- and T-lineage acute lymphoblastic leukaemias. *Br J Haematol* 1996; 95(3): 518–523.

12. Yasui W, Akama Y, Kuniyasu H, et al. Expression of cyclin E in human gastric adenomas and adenocarcinomas: correlation with proliferative activity and p53 status. *J Exp Ther Oncol* 1996; 1(2): 88–94.
13. Iida H, Towatari M, Tanimoto M, et al. Overexpression of cyclin E in acute myelogenous leukemia. *Blood* 1997; 90(9): 3707–3713.
14. Molendini L, Benassi MS, Magagnoli G, et al. Prognostic significance of cyclin expression in human osteosarcoma. *Int J Oncol* 1998; 12(5): 1007–1011.
15. Dong Y, Sui L, Tai Y, et al. Prognostic significance of cyclin E overexpression in laryngeal squamous cell carcinomas. *Clin Cancer Res* 2000; 6(11): 4253–4258.
16. Fukuse T, Hirata T, Naiki H, et al. Prognostic significance of cyclin E overexpression in resected non-small cell lung cancer. *Cancer Res* 2000; 60(2): 242–244.
17. Erlanson M, Landberg G. Prognostic implications of p27 and cyclin E protein contents in malignant lymphomas. *Leuk Lymphoma* 2001; 40(5–6): 461–470.
18. Muller-Tidow C, Metzger R, Kugler K, et al. Cyclin E is the only cyclin-dependent kinase 2-associated cyclin that predicts metastasis and survival in early stage non-small cell lung cancer. *Cancer Res* 2001; 61(2): 647–653.
19. Schraml P, Bucher C, Bissig H, et al. Cyclin E overexpression and amplification in human tumours. *J Pathol* 2003; 200(3): 375–382.
20. Tissier F, Louvel A, Grabar S, et al. Cyclin E correlates with malignancy and adverse prognosis in adrenocortical tumors. *Eur J Endocrinol* 2004; 150(6): 809–817.
21. Ortega S, Malumbres M, Barbacid M. Cyclin D-dependent kinases, INK4 inhibitors and cancer. *Biochim Biophys Acta* 2002; 1602(1): 73–87.
22. Lammie GA, Peters G. Chromosome 11q13 abnormalities in human cancer. *Cancer Cells* 1991; 3(11): 413–420.
23. Reissmann PT, Koga H, Figlin RA, Holmes EC, Slamon DJ. Amplification and overexpression of the cyclin D1 and epidermal growth factor receptor genes in non-small-cell lung cancer. Lung Cancer Study Group. *J Cancer Res Clin Oncol* 1999; 125(2): 61–70.
24. Rodrigo JP, Garcia LA, Ramos S, Lazo PS, Suarez C. EMS1 gene amplification correlates with poor prognosis in squamous cell carcinomas of the head and neck. *Clin Cancer Res* 2000; 6(8): 3177–3182.
25. Cheung TH, Yu MM, Lo KW, Yim SF, Chung TK, Wong YF. Alteration of cyclin D1 and CDK4 gene in carcinoma of uterine cervix. *Cancer Lett* 2001; 166(2): 199–206.
26. Fujii M, Ishiguro R, Yamashita T, Tashiro M. Cyclin D1 amplification correlates with early recurrence of squamous cell carcinoma of the tongue. *Cancer Lett* 2001; 172(2): 187–192.
27. Vielba R, Bilbao J, Ispizua A, et al. p53 and cyclin D1 as prognostic factors in squamous cell carcinoma of the larynx. *Laryngoscope* 2003; 113(1): 167–172.
28. Lammie GA, Fantl V, Smith R, et al. D11S287, a putative oncogene on chromosome 11q13, is amplified and expressed in squamous cell and mammary carcinomas and linked to BCL-1. *Oncogene* 1991; 6(3): 439–444.
29. Buckley MF, Sweeny KJ, Hamilton JA, et al. Expression and amplification of cyclin genes in human breast cancer. *Oncogene* 1993; 8(8): 2127–2133.
30. Dickson C, Fantl V, Gillett C, et al. Amplification of chromosome band 11q13 and a role for cyclin D1 in human breast cancer. *Cancer Lett* 1995; 90(1): 43–50.
31. Bartkova J, Lukas J, Muller H, Lutzhoft D, Strauss M, Bartek J. Cyclin D1 protein expression and function in human breast cancer. *Int J Cancer* 1994; 57(3): 353–361.
32. Bartkova J, Lukas J, Strauss M, Bartek J. Cyclin D1 oncoprotein aberrantly accumulates in malignancies of diverse histogenesis. *Oncogene* 1995; 10(4): 775–778.
33. Gillett C, Fantl V, Smith R, et al. Amplification and overexpression of cyclin D1 in breast cancer detected by immunohistochemical staining. *Cancer Res* 1994; 54(7): 1812–1827.
34. McIntosh GG, Anderson JJ, Milton I, et al. Determination of the prognostic value of cyclin D1 overexpression in breast cancer. *Oncogene* 1995; 11(5): 885–891.
35. Gillett C, Smith P, Gregory W, et al. Cyclin D1 and prognosis in human breast cancer. *Int J Cancer* 1996; 69(2): 92–99.
36. Weinstat-Saslow D, Merino MJ, Manrow RE, et al. Overexpression of cyclin D mRNA distinguishes invasive and in situ breast carcinomas from non-malignant lesions. *Nat Med* 1995; 1(12): 1257–1260.
37. Delmer A, Ajchenbaum-Cymbalista F, Tang R, et al. Over-expression of cyclin D1 in chronic B-cell malignancies with abnormality of chromosome 11q13. *Br J Haematol* 1995; 89(4): 798–804.
38. Motokura T, Arnold A. Cyclin D and oncogenesis. *Curr Opin Genet Dev* 1993; 3(1): 5–10.

39. Buschges R, Weber RG, Actor B, Lichter P, Collins VP, Reifenger G. Amplification and expression of cyclin D genes (CCND1, CCND2 and CCND3) in human malignant gliomas. *Brain Pathol* 1999; 9(3): 435–442; discussion 432–433.
40. Ito Y, Takeda T, Wakasa K, Tsujimoto M, Matsuura N. Expression and possible role of cyclin D3 in human pancreatic adenocarcinoma. *Anticancer Res* 2001; 21(2A): 1043–1048.
41. Shaughnessy J Jr, Gabrea A, Qi Y, et al. Cyclin D3 at 6p21 is dysregulated by recurrent chromosomal translocations to immunoglobulin loci in multiple myeloma. *Blood* 2001; 98(1): 217–223.
42. Filipits M, Jaeger U, Pohl G, et al. Cyclin D3 is a predictive and prognostic factor in diffuse large B-cell lymphoma. *Clin Cancer Res* 2002; 8(3): 729–733.
43. Hedberg Y, Davoodi E, Ljungberg B, Roos G, Landberg G. Cyclin E and p27 protein content in human renal cell carcinoma: clinical outcome and associations with cyclin D. *Int J Cancer* 2002; 102(6): 601–607.
44. An HX, Beckmann MW, Reifenger G, Bender HG, Neideracher D. Gene amplification and overexpression of CDK4 in sporadic breast carcinomas is associated with high tumor cell proliferation. *Am J Pathol* 1999; 154(1): 113–118.
45. Khatib ZA, Matsushime H, Valentine M, Shapiro DN, Sherr CJ, Look AT. Coamplification of the CDK4 gene with MDM2 and GLI in human sarcomas. *Cancer Res* 1993; 53(22): 5535–5541.
46. Schmidt EE, Ichimura K, Reifenger G, Collins VP. CDKN2 (p16/MTS1) gene deletion or CDK4 amplification occurs in the majority of glioblastomas. *Cancer Res* 1994; 54(24): 6321–6324.
47. He J, Olson JJ, James CD. Lack of *p16INK4* or retinoblastoma protein (pRb), or amplification-associated overexpression of *cdk4* is observed in distinct subsets of malignant glial tumors and cell lines. *Cancer Res* 1995; 55(21): 4833–4866.
48. Wei G, Lonardo F, Ueda T, et al. CDK4 gene amplification in osteosarcoma: reciprocal relationship with INK4A gene alterations and mapping of 12q13 amplicons. *Int J Cancer* 1999; 80(2): 199–204.
49. Simon R, Struckmann K, Schraml P, et al. Amplification pattern of 12q13-q15 genes (MDM2, CDK4, GLI) in urinary bladder cancer. *Oncogene* 2002; 21(16): 2476–2483.
50. Cairns P, Mao L, Merlo A, et al. Rates of p16 (MTS1) mutations in primary tumors with 9p loss. *Science* 1994; 265(5170): 415–417.
51. Nobori T, Miura K, Lois A, Takabayashi K, Carson DA. Deletions of the cyclin-dependent kinase-4 inhibitor gene in multiple human cancers. *Nature* 1994; 368(6473): 753–756.
52. Spruck CH 3rd, Gonzalez-Zulueta M, Shibata A, et al. p16 gene in uncultured tumours. *Nature* 1994; 370(6486): 183–184.
53. Herman JG, Merlo A, Mao L, et al. Inactivation of the CDKN2/p16/MTS1 gene is frequently associated with aberrant DNA methylation in all common human cancers. *Cancer Res* 1995; 55(20): 4525–4530.
54. Borg A, Sandberg T, Nilsson K, et al. High frequency of multiple melanomas and breast and pancreas carcinomas in CDKN2A mutation-positive melanoma families. *J Natl Cancer Inst* 2000; 92(15): 1260–1266.
55. Thomas DM, Yang HS, Alexander K, Hinds PW. Role of the retinoblastoma protein in differentiation and senescence. *Cancer Biol Ther* 2003; 2(2): 124–130.
56. Sgambato A, Cittadini A, Faraglia B, Weinstein IB. Multiple functions of p27(Kip1) and its alterations in tumor cells: a review. *J Cell Physiol* 2000; 183(1): 18–27.
57. Kawamata N, Morosetti R, Miller CW, et al. Molecular analysis of the cyclin-dependent kinase inhibitor gene p27/Kip1 in human malignancies. *Cancer Res* 1995; 55(11): 2266–2269.
58. Blain SW, Massague J. Breast cancer banishes p27 from nucleus. *Nat Med* 2002; 8(10): 1076–1078.
59. Slingerland J, Pagano M. Regulation of the cdk inhibitor p27 and its deregulation in cancer. *J Cell Physiol* 2000; 183(1): 10–17.
60. Esposito V, Baldi A, De Luca A, et al. Prognostic role of the cyclin-dependent kinase inhibitor p27 in non-small cell lung cancer. *Cancer Res* 1997; 57(16): 3381–3385.
61. Catzavelos C, Bhattacharya N, Ung YC, et al. Decreased levels of the cell-cycle inhibitor p27Kip1 protein: prognostic implications in primary breast cancer. *Nat Med* 1997; 3(2): 227–230.
62. Loda M, Cukor B, Tam SW, et al. Increased proteasome-dependent degradation of the cyclin-dependent kinase inhibitor p27 in aggressive colorectal carcinomas. *Nat Med* 1997; 3(2): 231–234.
63. Masciullo V, Sgambato A, Pacilio C, et al. Frequent loss of expression of the cyclin-dependent kinase inhibitor p27 in epithelial ovarian cancer. *Cancer Res* 1999; 59(15): 3790–3794.
64. Singh SP, Lipman J, Goldman H, et al. Loss or altered subcellular localization of p27 in Barrett's associated adenocarcinoma. *Cancer Res* 1998; 58(8): 1730–1735.
65. Baldassarre G, Belletti B, Bruni P, et al. Overexpressed cyclin D3 contributes to retaining the growth inhibitor p27 in the cytoplasm of thyroid tumor cells. *J Clin Invest* 1999; 104(7): 865–874.

66. Tsihlias J, Kapusta LR, DeBoer G, et al. Loss of cyclin-dependent kinase inhibitor p27Kip1 is a novel prognostic factor in localized human prostate adenocarcinoma. *Cancer Res* 1998; 58(3): 542–548.
67. Mizumatsu S, Tamiya T, Ono Y, et al. Expression of cell cycle regulator p27Kip1 is correlated with survival of patients with astrocytoma. *Clin Cancer Res* 1999; 5(3): 551–557.
68. Erlanson M, Portin C, Linderholm B, Lindh J, Roos G, Landberg G. Expression of cyclin E and the cyclin-dependent kinase inhibitor p27 in malignant lymphomas-prognostic implications. *Blood* 1998; 92(3): 770–777.
69. Yamasaki L, Pagano M. Cell cycle, proteolysis and cancer. *Curr Opin Cell Biol* 2004; 16(6): 623–628.
70. Orend G, Hunter T, Ruoslahti E. Cytoplasmic displacement of cyclin E-cdk2 inhibitors p21Cip1 and p27Kip1 in anchorage-independent cells. *Oncogene* 1998; 16(20): 2575–2583.
71. Soucek T, Yeung RS, Hengstschlager M. Inactivation of the cyclin-dependent kinase inhibitor p27 upon loss of the tuberous sclerosis complex gene-2. *Proc Natl Acad Sci USA* 1998; 95(26): 15,653–15,658.
72. Yamasaki L. Role of the RB tumor suppressor in cancer. *Cancer Treat Res* 2003; 115: 209–239.
73. Burke L, Flieder DB, Guinee DG, et al. Prognostic implications of molecular and immunohistochemical profiles of the Rb and p53 cell cycle regulatory pathways in primary non-small cell lung carcinoma. *Clin Cancer Res* 2005; 11(1): 232–241.
74. Zhu L, van den Heuvel S, Helin K, et al. Inhibition of cell proliferation by p107, a relative of the retinoblastoma protein. *Genes Dev* 1993; 7(7A): 1111–1125.
75. Goodrich DW, Wang NP, Qian YW, Lee EY, Lee WH. The retinoblastoma gene product regulates progression through the G1 phase of the cell cycle. *Cell* 1991; 67(2): 293–302.
76. Starostik P, Chow KN, Dean DC. Transcriptional repression and growth suppression by the p107 pocket protein. *Mol Cell Biol* 1996; 16(7): 3606–3614.
77. Claudio PP, Howard CM, Baldi A, et al. p130/pRb2 has growth suppressive properties similar to yet distinctive from those of retinoblastoma family members pRb and p107. *Cancer Res* 1994; 54(21): 5556–5560.
78. Nevins JR. Toward an understanding of the functional complexity of the E2F and retinoblastoma families. *Cell Growth Differ* 1998; 9(8): 585–593.
79. Dyson N. The regulation of E2F by pRB-family proteins. *Genes Dev* 1998; 12(15): 2245–2262.
80. Moberg K, Starz MA, Lees JA. E2F-4 switches from p130 to p107 and pRB in response to cell cycle reentry. *Mol Cell Biol* 1996; 16(4): 1436–1449.
81. Slansky JE, Farnham PJ. Introduction to the E2F family: protein structure and gene regulation. *Curr Top Microbiol Immunol* 1996; 208: 1–30.
82. Weinberg RA. The retinoblastoma protein and cell cycle control. *Cell* 1995; 81(3): 323–330.
83. Mittnacht S. Control of pRB phosphorylation. *Curr Opin Genet Dev* 1998; 8(1): 21–27.
84. Smith EJ, Leone G, DeGregori J, Jakoi L, Nevins JR. The accumulation of an E2F-p130 transcriptional repressor distinguishes a G0 cell state from a G1 cell state. *Mol Cell Biol* 1996; 16(12): 6965–6976.
85. Knudsen ES, Wang JY. Differential regulation of retinoblastoma protein function by specific Cdk phosphorylation sites. *J Biol Chem* 1996; 271(14): 8313–8320.
86. Lundberg AS, Weinberg RA. Functional inactivation of the retinoblastoma protein requires sequential modification by at least two distinct cyclin-cdk complexes. *Mol Cell Biol* 1998; 18(2): 753–761.
87. Bartek J, Bartkova J, Lukas J. The retinoblastoma protein pathway in cell cycle control and cancer. *Exp Cell Res* 1997; 237(1): 1–6.
88. Sherr CJ. Cancer cell cycles. *Science* 1996; 274(5293): 1672–1677.
89. Cobrinik D, Whyte P, Peeper DS, Jacks T, Weinberg RA. Cell cycle-specific association of E2F with the p130 E1A-binding protein. *Genes Dev* 1993; 7(12A): 2392–2404.
90. De Luca A, Baldi A, Esposito V, et al. The retinoblastoma gene family pRb/p105, p107, pRb2/p130 and simian virus-40 large T-antigen in human mesotheliomas. *Nat Med* 1997; 3(8): 913–916.
91. Kornblau SM, Chen N, del Giglio A, O'Brien S, Deisseroth AB. Retinoblastoma protein expression is frequently altered in chronic lymphocytic leukemia. *Cancer Res* 1994; 54(1): 242–246.
92. Kornblau SM, Andreef M, Hu SX, et al. Low and maximally phosphorylated levels of the retinoblastoma protein confer poor prognosis in newly diagnosed acute myelogenous leukemia: a prospective study. *Clin Cancer Res* 1998; 4(8): 1955–1963.
93. Sauerbrey A, Stammer G, Zintl F, Volm M. Expression of the retinoblastoma tumor suppressor gene (RB-1) in acute leukemia. *Leuk Lymphoma* 1998; 28(3–4): 275–283.
94. Brambilla E, Moro D, Gazzeri S, Brambilla C. Alterations of expression of Rb, p16(INK4A) and cyclin D1 in non-small cell lung carcinoma and their clinical significance. *J Pathol* 1999; 188(4): 351–360.



95. Baldi A, Esposito V, De Luca A, et al. Differential expression of the retinoblastoma gene family members pRb/p105, p107, and pRb2/p130 in lung cancer. *Clin Cancer Res* 1996; 2(7): 1239–1245.
96. Omura K, Nagasato A, Kanehira E, et al. Retinoblastoma protein and proliferating-cell nuclear antigen expression as predictors of recurrence in well-differentiated papillary thyroid carcinoma. *J Clin Oncol* 1997; 15(12): 3458–3463.
97. Cordon-Cardo C, Wartinger D, Petrylak D, et al. Altered expression of the retinoblastoma gene product: prognostic indicator in bladder cancer. *J Natl Cancer Inst* 1992; 84(16): 1251–1256.
98. Theodorescu D, Broder SR, Boyd JC, Mills SE, Frierson HF, Jr. p53, bcl-2 and retinoblastoma proteins as long-term prognostic markers in localized carcinoma of the prostate. *J Urol* 1997; 158(1): 131–137.
99. Tamboli P, Amin MB, Xu HJ, Linden MD. Immunohistochemical expression of retinoblastoma and p53 tumor suppressor genes in prostatic intraepithelial neoplasia: comparison with prostatic adenocarcinoma and benign prostate. *Mod Pathol* 1998; 11(3): 247–252.
100. Dong Y, Walsh MD, McGuckin MA, et al. Reduced expression of retinoblastoma gene product (pRB) and high expression of p53 are associated with poor prognosis in ovarian cancer. *Int J Cancer* 1997; 74(4): 407–415.
101. Nakamura M, Konishi N, Tsunoda S, et al. Retinoblastoma protein expression and MIB-1 correlate with survival of patients with malignant astrocytoma. *Cancer* 1997; 80(2): 242–249.
102. Korkolopoulou PA, Angelopoulou MK, Kontopidou FN, et al. Retinoblastoma gene product and P21 (WAF1, CIP1) protein expression in non Hodgkin's lymphomas: a multivariate survival analysis. *Leuk Lymphoma* 2001; 40(5–6): 647–658.
103. Baldi A, Esposito V, De Luca A, et al. Differential expression of Rb2/p130 and p107 in normal human tissues and in primary lung cancer. *Clin Cancer Res* 1997; 3(10): 1691–1697.
104. Susini T, Baldi F, Howard CM, et al. Expression of the retinoblastoma-related gene Rb2/p130 correlates with clinical outcome in endometrial cancer. *J Clin Oncol* 1998; 16(3): 1085–1093.
105. Susini T, Massi D, Paglierani M, et al. Expression of the retinoblastoma-related gene Rb2/p130 is downregulated in atypical endometrial hyperplasia and adenocarcinoma. *Hum Pathol* 2001; 32(4): 360–367.
106. Milde-Langosch K, Goemann C, Methner C, Rieck G, Bamberger AM, Loning T. Expression of Rb2/p130 in breast and endometrial cancer: correlations with hormone receptor status. *Br J Cancer* 2001; 85(4): 546–551.
107. Massaro-Giordano M, Baldi G, De Luca A, Baldi A, Giordano A. Differential expression of the retinoblastoma gene family members in choroidal melanoma: prognostic significance. *Clin Cancer Res* 1999; 5(6): 1455–1458.
108. Leoncini L, Bellan C, Cossu A, et al. Retinoblastoma-related p107 and pRb2/p130 proteins in malignant lymphomas: distinct mechanisms of cell growth control. *Clin Cancer Res* 1999; 5(12): 4065–4072.
109. Zamparelli A, Masciullo V, Bovicelli A, et al. Expression of cell-cycle-associated proteins pRB2/p130 and p27kip in vulvar squamous cell carcinomas. *Hum Pathol* 2001; 32(1): 4–9.
110. Claudio PP, Zamparelli A, Garcia FU, et al. Expression of cell-cycle-regulated proteins pRb2/p130, p107, p27(kip1), p53, mdm-2, and Ki-67 (MIB-1) in prostatic gland adenocarcinoma. *Clin Cancer Res* 2002; 8(6): 1808–1815.
111. D'Andrilli G, Masciullo V, Bagella L, et al. Frequent loss of pRb2/p130 in human ovarian carcinoma. *Clin Cancer Res* 2004; 10(9): 3098–4103.
112. Xu B, Lim DS, Kastan MB. Two molecularly distinct G(2)/M checkpoints are induced by ionizing irradiation. *Mol Cell Biol* 2002; 22(4): 1049–1059.
113. Nyberg KA, Michelson RJ, Putnam CW, Weinert TA. Toward maintaining the genome: DNA damage and replication checkpoints. *Annu Rev Genet* 2002; 36: 617–656.
114. Donzelli M, Draetta GF. Regulating mammalian checkpoints through Cdc25 inactivation. *EMBO Rep* 2003; 4(7): 671–677.
115. Bulavin DV, Higashimoto Y, Popoff IJ, et al. Initiation of a G2/M checkpoint after ultraviolet radiation requires p38 kinase. *Nature* 2001; 411(6833): 102–107.
116. Taylor WR, Stark GR. Regulation of the G2/M transition by p53. *Oncogene* 2001; 20(15): 1803–1815.
117. Zhou BB, Bartek J. Targeting the checkpoint kinases: chemosensitization versus chemoprotection. *Nat Rev Cancer* 2004; 4(3): 216–225.

# II

---

## OVARIAN CANCER

---

# 2

---

## Ovarian Serous Carcinogenesis— A Proposed Model

---

*Ie-Ming Shih, MD, PhD,  
and Robert J. Kurman, MD, PhD*

### CONTENTS

INTRODUCTION
THE CLINICOPATHOLOGICAL BASIS OF THE PROPOSED MODEL
THE PROPOSED TUMORIGENIC MODEL OF OVARIAN CARCINOMA
TYPE I AND TYPE II TUMORS ARE CHARACTERIZED BY UNIQUE MOLECULAR FEATURES
FUTURE PERSPECTIVES IN STUDYING OVARIAN TUMORS
CONCLUSION
REFERENCES

---

### 1. INTRODUCTION

Ovarian cancer is one of the most fatal malignant diseases in women. In 2004, it accounted for approx 16,090 deaths (1). About 25,000 new cases are diagnosed annually, of which approx 75% are diagnosed at an advanced stage. Ovarian cancer is a heterogenous group of tumors, but the most common type is surface epithelial tumors, which are classified into serous, mucinous, endometrioid, clear cell, and Brenner (transitional) tumors corresponding to different types of epithelia in the organs of the female reproductive tract (2–4). The tumors in each of the categories are further subclassified into three groups, benign, intermediate (borderline tumor), and malignant to reflect their clinical behavior.

Despite considerable efforts aimed at elucidating the molecular mechanisms in the development of ovarian carcinoma, its pathogenesis is still largely unknown because of the lack of correlated morphological and molecular genetic studies (5,6). Based on a review of clinicopathological and molecular studies, a model for their development has been proposed. In this model, surface epithelial tumors are broadly divided into two categories designated type I and type II tumors, which correspond to two main pathways of tumorigenesis. Type I tumors are made up of low-grade serous carcinomas, mucinous carcinomas, endometrioid carcinomas, malignant Brenner tumors, and clear cell carcinomas. They tend to be low-grade neoplasms that arise in a stepwise fashion from borderline tumors whereas type II tumors are high-grade neoplasms for which

From: *Current Clinical Oncology: Molecular Pathology of Gynecologic Cancer*  
Edited by: A. Giordano, A. Bovicelli, and R. Kurman © Humana Press Inc., Totowa, NJ

morphologically recognizable precursor lesions have not been identified, so-called “*de novo*” development. This model reconciles the relationship of borderline tumors to invasive carcinoma of different histological types and provides a morphological and molecular framework for studies aimed at elucidating the pathogenesis of ovarian cancer. This chapter will describe the proposed model with special emphasis on serous tumors, as they are the most common surface epithelial tumors.

## 2. THE CLINICOPATHOLOGICAL BASIS OF THE PROPOSED MODEL

In the last several years, attempts have been made to characterize the clinicopathological features of noninvasive and invasive epithelial ovarian tumors of all histological types in an effort to elucidate their pathogenesis and behavior (2,7–9). These studies identified a subset of low-grade serous tumors originally designated “micropapillary serous carcinoma (MPSC)” with characteristic histopathological features, low proliferative activity, and an indolent behavior. These tumors contrast dramatically with the conventional type of serous carcinoma, which is a high-grade aggressive neoplasm that has high proliferative activity (2,7,9). The term “MPSC” was originally proposed to distinguish the noninvasive form of this tumor from the more common noninvasive tumor, termed an “atypical proliferative serous tumor,” both of which have been included under the rubric of “borderline” or “low-malignant potential” (7,9). Subsequent studies have suggested that MPSC is the precursor or *in situ* lesion of invasive low-grade serous carcinoma and therefore, the term “intraepithelial low-grade serous carcinoma” is preferred. Histological transitions from cystadenoma/adenofibromas and atypical proliferative serous tumors to intraepithelial low-grade serous carcinomas are observed in nearly 75% of cases (10). In addition, areas of infiltrative growth (stromal invasion) immediately adjacent to the intraepithelial component are found in a significant proportion of cases (10). The aforementioned histopathological findings strongly suggest that there is a spectrum of tumor progression beginning with a benign serous cystadenoma/adenofibroma, through a proliferative tumor (atypical proliferative serous tumor) to an intraepithelial low-grade serous carcinoma and finally, to an invasive low-grade serous carcinoma.

Usually, patients with low-grade serous carcinomas have an indolent course that might last as long as 20 years (9,10). Approximately 50% of patients with low-grade serous carcinoma ultimately succumb to their disease because of widespread intra-abdominal carcinomatosis. But the tumor generally maintains its low-grade appearance and low proliferative index throughout its course (10). This contrasts with high-grade serous carcinoma, which presents as an aggressive neoplasm that spreads rapidly and is associated with a poor outcome. Analysis of nonserous ovarian tumors including mucinous, endometrioid, clear cell carcinomas, and malignant Brenner tumors reveal that they are often associated with cystadenomas, borderline tumors, and intraepithelial carcinomas (2). Furthermore, it has been long recognized that endometrioid carcinoma and clear cell carcinoma are associated with endometriosis in the ovary or pelvis in 15–50% of cases (11,12). This finding suggests that endometriosis is a precursor of these tumors. In parallel with the aforementioned clinical observation, a recent transvaginal ultrasonography study has shown that approx 50% of ovarian carcinomas develop from pre-existing cystic lesions, whereas the remaining 50% develop in ovaries without an apparent abnormality on ultrasound (13). The former group was mainly

made up of mucinous, endometrioid, clear cell carcinomas, and borderline tumors, whereas the latter group was made up almost exclusively of high-grade serous carcinomas. This distribution corresponds to the type I and type II tumors.

### 3. THE PROPOSED TUMORIGENIC MODEL OF OVARIAN CARCINOMA

The clinicopathological observations described earlier, provide the basis for a proposed model of ovarian carcinogenesis, in which there are two main pathways, corresponding to type I and type II tumors. The tumor types, putative precursor lesions and associated molecular genetic alterations are summarized in Table 1. It should be emphasized that the terms, type I and type II, refer to tumorigenic pathways and are not specific histopathological terms. Type I tumors (low-grade serous carcinoma, mucinous carcinoma, endometrioid carcinoma, malignant Brenner tumor, and clear cell carcinoma) develop in a stepwise fashion from well-recognized precursors, namely “borderline” tumors, which in turn, develop from cystadenomas/adenofibromas (Fig. 1; Table 1) (14). The benign tumors appear to develop from the surface epithelium or inclusion cysts in the case of serous and mucinous tumors and from endometriosis or endometriomas in the case of endometrioid and clear cell tumors. Type I tumors are slow growing as evidenced by the observation that they are large and often confined to the ovary at diagnosis. In contrast, type II tumors are high-grade and usually have spread beyond the ovaries at presentation. Type II carcinomas include what are currently classified as high-grade serous carcinoma (“moderately” and “poorly” differentiated), malignant mixed mesodermal tumors (carcinosarcomas), and undifferentiated carcinoma (Fig. 1; Table 1). Once believed to be mixed tumors consisting of carcinoma and sarcoma, malignant mixed mesodermal tumors (carcinosarcomas) have been shown to be monoclonal (15,16) and accordingly, these tumors are currently considered high-grade carcinomas with a metaplastic sarcomatous component. Type II carcinomas evolve rapidly, disseminate early in their course and are highly aggressive. As these tumors are rarely associated with morphologically recognizable precursor lesions; it has been proposed that they develop “*de novo*” from the surface epithelium or inclusion cysts of the ovary (17). It is likely that conventional high-grade serous carcinoma does not develop “*de novo*,” but from precursor lesions termed “dysplasia” by some in inclusion cysts that undergo rapid transition from a microscopic carcinoma to a clinically diagnosed carcinoma. Although, it is believed that the proposed model accounts for the development of most ovarian carcinomas, it is likely that other pathways of tumorigenesis exist. For example, it is not clear whether some low-grade serous carcinomas (type I) progress to high-grade serous carcinomas and whether there are other subsets of type II carcinomas. Molecular profiling and epidemiological studies will be important to determine whether there are distinct subsets of type II tumors.

### 4. TYPE I AND TYPE II TUMORS ARE CHARACTERIZED BY UNIQUE MOLECULAR FEATURES

Because serous carcinoma is the most common type of ovarian carcinoma, this discussion is focussed on low- and high-grade serous carcinomas as they represent the prototypes of type I and type II carcinomas, respectively. Both low- and high-grade serous carcinomas can be distinguished by unique molecular genetic alterations. Among

**Table 1**  
**Precursors and Molecular Genetic Alterations of Type I and Type II Tumors of the Ovary**

<i>Type I tumors</i>	<i>Precursors<sup>a</sup></i>	<i>Known molecular genetic alterations</i>
Low-grade serous carcinoma	Serous cystadenoma/adenofibroma Atypical proliferative serous tumor Intraepithelial low-grade carcinoma	<i>BRAF</i> and <i>KRAS</i> mutations (~67%)
Mucinous carcinoma	Mucinous cystadenoma Atypical proliferative mucinous tumor Intraepithelial carcinoma	<i>KRAS</i> mutations (>60%)
Endometrioid carcinoma	Endometriosis Endometrioid adenofibroma Atypical proliferative endometrioid tumor Intraepithelial carcinoma	LOH or mutations in <i>PTEN</i> (20%) $\beta$ -catenin gene mutations (16–54%) <i>KRAS</i> mutations (<10%) Microsatellite instability (13–50%)
Clear cell carcinoma	Endometriosis Clear cell adenofibroma Atypical proliferative clear cell tumor Intraepithelial carcinoma	<i>KRAS</i> mutations (5–16%) Microsatellite instability (~13%) TGF- $\beta$ RII mutation (66%) <sup>b</sup>
Malignant Brenner (transitional) tumor	Brenner tumor Atypical proliferative Brenner tumor	Not yet identified
<i>Type II tumors</i>	<i>Precursors</i>	<i>Known molecular genetic alterations</i>
High-grade serous carcinoma	Not yet identified	<i>p53</i> mutations (50–80%) Amplification and overexpression of <i>HER2/neu</i> gene (10%–20%) and <i>AKT2</i> gene (12–18%) Inactivation of <i>p16</i> gene (10–17%)
Undifferentiated carcinoma	Not yet identified	Not yet identified
Malignant mixed mesodermal tumor (carcinosarcomas)	Not yet identified	<i>p53</i> mutations (>90%)

LOH, loss of heterozygosity; TGF, transforming growth factor.

<sup>a</sup>Atypical proliferative serous tumors and intraepithelial low-grade serous carcinoma have been termed “serous borderline” tumors in the literature. Similarly, for mucinous, endometrioid, clear cell, and Brenner tumors, atypical proliferative tumor, and intraepithelial carcinoma have been combined and designated “borderline tumor” in the literature.

<sup>b</sup>Based on preliminary results analyzing three cases (61).

them, the most well-studied molecular alterations are mutations in *KRAS* and *BRAF* oncogenes in low-grade serous carcinoma and mutations in *p53* tumor-suppressor gene in high-grade serous carcinoma. *KRAS* and *BRAF* genes are the upstream regulators in the *RAS/RAF/MEK/ERK/MAP* signal transduction pathway, which plays a critical role

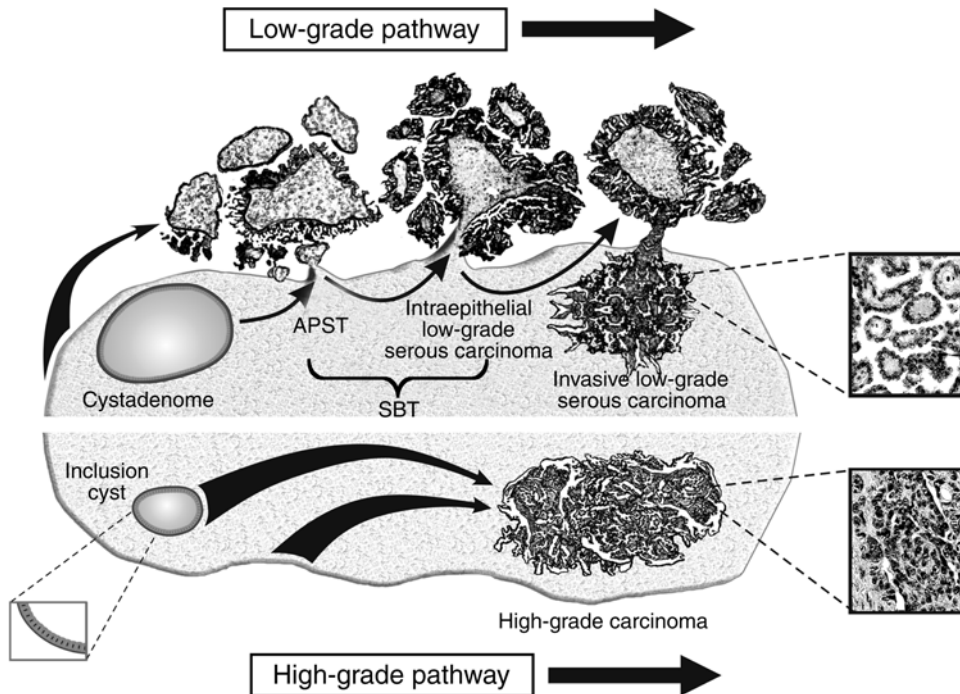

**Fig. 1.** Schematic representation of the dualistic model depicting the development of ovarian serous carcinomas, the most common type of ovarian cancer. Low-grade serous carcinoma represents the prototypic type I tumor and develops in a stepwise fashion from an atypical proliferative tumor through an intraepithelial or *in situ* stage of low-grade serous carcinomas (both of these tumors qualified as “borderline”) before becoming invasive. These tumors are associated with frequent *KRAS* or *BRAF* mutations. High-grade serous carcinoma represents the prototypic type II tumor and develops from the ovarian surface epithelium or inclusion cysts without morphologically recognizable intermediate stages. *KRAS* and *BRAF* mutations have not been found in any of these neoplasms (14,19,68). CIN: chromosomal instability.

in the transmission of growth signals into the nucleus (18). Oncogenic mutations in *BRAF* and *KRAS* result in constitutive activation of this pathway and contribute to neoplastic transformation. Recent studies (14,19) have demonstrated that *KRAS* mutations at codons 12 and 13 occur in 35% of invasive low-grade serous carcinomas and 33% of borderline tumors (atypical proliferative tumor and intraepithelial low-grade carcinoma), but not in high-grade serous carcinomas. Similarly, *BRAF* mutations at codon 599 occur in 30% of low-grade serous carcinomas and 28% of borderline tumors, but not in high-grade serous carcinomas (19). Accordingly, mutations in either *KRAS* or *BRAF* were found in 65% of invasive low-grade serous carcinomas and in 68% of serous borderline tumors (atypical proliferative tumors and intraepithelial low-grade serous carcinomas). In contrast, neither of the genes is mutated in high-grade serous carcinomas (Fig. 2). It is of interest that *BRAF* mutations were found only in tumors with wild-type *KRAS* and vice versa (19). The mutually exclusive nature of *BRAF* mutations at codon 599 and *KRAS* mutations at codons 12 and 13 in ovarian carcinoma is consistent with similar findings in melanoma and colorectal carcinoma (20,21), and lends support to the view that *KRAS* and *BRAF* mutations have an equivalent effect on tumorigenesis. Mutations of *KRAS* and *BRAF* appear to occur very early in the development of low-grade serous carcinoma. To investigate how early mutations of *KRAS*

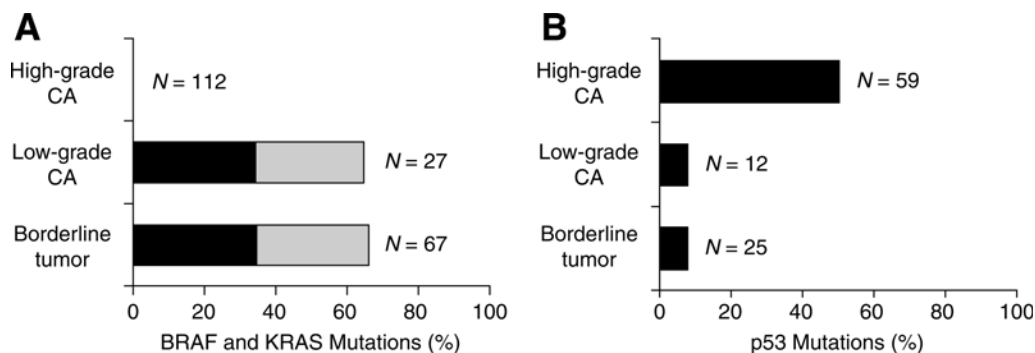

**Fig. 2.** Mutational analysis of *KRAS*, *BRAF*, and *p53* in ovarian serous tumors. **(A)** Mutations in either *KRAS* (black bars) or *BRAF* (gray bars) occur frequently in both serous borderline tumors and invasive low-grade serous carcinomas. The mutations are not detected in all high-grade serous carcinomas examined based on the previous study (19) and additional cases. **(B)** Mutations in *p53* are frequent in high-grade serous carcinoma, but are less frequent in serous borderline tumors and invasive low-grade serous carcinomas.

and *BRAF* occur in the development of serous borderline tumors, Ho et al. compared the mutational status of *KRAS* and *BRAF* in both SBTs and the adjacent epithelium from cystadenomas, the presumed precursor of SBTs. In that study, three of eight SBTs contained mutant *BRAF* and four SBTs contained mutant *KRAS*. All specimens with mutant *BRAF* harbored wild-type *KRAS* and vice versa. Thus, seven (88%) of eight SBTs contained either *KRAS* or *BRAF* mutations. The same mutations detected in SBTs were identified in the cystadenoma epithelium adjacent to the serous borderline tumor (SBTs) in six (86%) of seven informative cases. As compared with SBTs, the cystadenoma epithelium like ovarian surface epithelium lacks cytological atypia. The aforementioned findings provide cogent evidence that mutations of *KRAS* and *BRAF* occur in the epithelium of cystadenomas adjacent to SBTs and strongly suggest that they are very early events in tumorigenesis, preceding the development of SBT (22).

In contrast to low-grade serous carcinoma where mutations in *p53* are rare, mutations in *p53* are common in high-grade serous carcinomas. Most studies have shown that approx 50–80% of advanced stage, presumably high-grade, serous carcinomas have mutant *p53* (23–28). It has also been reported that mutant *p53* is present in 37% of stage I and II, presumably high-grade serous carcinomas (29). In a study of very early microscopic stage I serous carcinomas in ovaries removed prophylactically from women who were *BRCA* heterozygotes, overexpression of *p53*, and mutation of *p53* were found in all early invasive high-grade serous carcinomas as well as in the adjacent “dysplastic” surface epithelium (30). It is likely that inherited mutations in *BRCA* genes predispose the ovarian surface epithelium and inclusion cysts to neoplastic transformation through an increase in genetic instability. Although, sporadic ovarian carcinomas were not analyzed in this study, the clinical and pathological features of *BRCA*-linked ovarian carcinomas and their sporadic counterparts are indistinguishable, suggesting that their histogenesis is similar. Thus, although the molecular genetic findings are preliminary, they suggest that conventional high-grade serous carcinoma, in its very earliest stage resembles advanced stage serous carcinoma at the molecular as well as at the morphological level. Similar to high-grade serous carcinoma, malignant mixed



mesodermal tumors (carcinosarcomas) also demonstrate *p53* mutations in almost all analyzed cases (31–33). It has been reported that the same *p53* mutations occur in the epithelial and the mesenchymal components (31). Moreover, the fact that pure carcinomatous areas are often associated with sarcomatous components suggests a common derivation of both the epithelial and the mesenchymal components in these neoplasms (34). The finding that metastases from these tumors nearly always are made up of carcinoma, has led investigators to suggest that malignant mixed mesodermal tumors are metaplastic carcinomas.

Besides *p53* mutations, high-grade serous carcinomas demonstrate other molecular genetic changes including amplification of HER-2/neu tyrosine kinase gene (35), amplification of AKT2 serine/threonine kinase gene (36,37), amplification of Rsf-1 chromatin remodeling gene (38), and inactivation of the *p16* gene as a result of promoter methylation, mutation, or homozygous deletion of the *p16* gene. These genetic changes are rare in borderline tumors and invasive low-grade serous carcinomas. As these molecular genetic studies were not carefully correlated with the morphological findings and were described simply as “serous carcinomas,” they have been referred to as “presumably high-grade” because the vast majority of serous carcinomas are high grade. In addition to molecular genetic alterations, both low- and high-grade serous carcinomas are characterized by distinct gene expression profiles. For example, transcriptome-wide gene expression profiling has demonstrated that human leukocyte antigen (HLA)-G (39) and apolipoprotein E (apoE) (40) are overexpressed in most high-grade serous carcinomas, but rarely in low-grade serous carcinomas. HLA-G immunoreactivity, ranging from focal to diffuse, has been detected in 45 of 74 (61%) high-grade ovarian serous carcinomas, but in none of the 18 low-grade serous carcinomas or 26 serous borderline tumors (atypical proliferative tumors and noninvasive MPSCs) (39). A similar correlation of HLA-G expression with behavior has been observed in large cell carcinoma of the lung (41). A possible mechanism that explains the association of HLA-G expression with prognosis is that HLA-G appears to facilitate tumor cell evasion of the immune system by protecting malignant cells from lysis by natural killer cells (42).

The genes that are specifically expressed in other types of ovarian carcinomas remain largely unknown. Recently, hepatocyte nuclear factor-1 $\alpha$  and glutathione peroxidase 3 have been reported as molecular markers for ovarian clear cell carcinoma as both genes are highly expressed in ovarian clear cell carcinomas, but rarely in other ovarian carcinomas (43,44). Chromosomal instability as evidenced by allelic imbalance has been studied in high- and low-grade serous carcinomas as well as their precursors (14). A progressive increase in the degree of allelic imbalance of chromosomes 1p, 5q, 8p, 18q, 22q, and Xp was noted when comparing atypical proliferative tumors with intraepithelial and invasive low-grade serous carcinomas. The allelic imbalance patterns in atypical proliferative tumors were also found in intraepithelial low-grade serous carcinomas containing adjacent atypical proliferative tumor components, further supporting the view that atypical proliferative tumors are the precursors of low-grade serous carcinomas. In contrast, all high-grade serous carcinomas including the very earliest tumors showed high levels of allelic imbalance. As allelic imbalance reflects chromosomal instability, the aforementioned findings suggest a step-wise increase in chromosomal instability in the progression to low-grade serous carcinoma, in contrast to the high

level of chromosomal instability in high-grade serous carcinoma, even in their earliest stage of development.

The stepwise progression of type I carcinomas closely simulates the “adenoma-carcinoma” sequence in colorectal cancer. In mucinous carcinoma for example, morphological transitions from cystadenoma to an atypical proliferative tumor, to intraepithelial carcinoma, and invasive carcinoma have been recognized for some time. Also, an increasing frequency of *KRAS* mutations at codons 12 and 13 has been described in cystadenomas, borderline tumors, and mucinous carcinomas, respectively (45–49). In addition, mucinous carcinoma, and the adjacent mucinous cystadenoma, and borderline tumor share the same *KRAS* mutation (45). Similarly, in endometrioid carcinomas, mutation of  $\beta$ -catenin has been reported in approximately one-third of cases (50,51), and mutations of *KRAS* can also be observed, albeit at a lesser frequency (nearly 10%) in most studies (11,19,49,52,53). On the other hand, mutation of the tumor suppressor, *PTEN*, occurs in 20% of endometrioid carcinomas, rising to 46% in these tumors with 10q23 loss of heterozygosity (54). Moreover, similar molecular genetic alterations including loss of heterozygosity at 10q23 and mutations in *PTEN* have been reported in endometriosis, atypical endometriosis, and ovarian endometrioid carcinoma in the same specimen (54–59). The molecular genetic findings together with the morphological data showing a frequent association of endometriosis with endometrioid adenofibromas and atypical proliferative (borderline) tumors, adjacent to invasive well-differentiated endometrioid carcinoma provide evidence of stepwise tumor progression in the development of endometrioid carcinoma. The importance of the genetic changes is highlighted by a recent report showing that inactivation of *PTEN* and activating mutation of *KRAS* are sufficient to induce the development of ovarian endometrioid carcinoma in a mouse model (60). Clear cell carcinoma is also frequently associated with endometriosis, clear cell adenofibromas, and atypical proliferative (borderline) clear cell tumors. But molecular evidence for the stepwise progression model is lacking because molecular markers specific to clear cell neoplasms have only recently been identified (43,44). Mutations in transforming growth factor- $\beta$  receptor type II has been found in two of three clear cell carcinomas, but rarely in other histological types of ovarian carcinomas (61). Microsatellite instability is present in endometrioid and clear cell carcinoma, but is only rarely detected in serous and mucinous tumors (62,63). These findings provide further evidence of the close relationship of endometrioid and clear cell carcinoma and point to a common precursor lesion for these two neoplasms.

## 5. FUTURE PERSPECTIVES IN STUDYING OVARIAN TUMORS

The tumorigenesis model described here provides a framework for future molecular and clinical studies of ovarian cancer (64). There are several research directions that need to be addressed in order to better understand the pathogenesis of ovarian carcinoma. The most critical include the introduction of new molecular genetic tools and population-based studies of ovarian serous borderline tumors. First, the key molecular events that are involved in the development of different subtypes of ovarian carcinoma are largely unknown. Several elegant studies have used gene expression profiling as the discovery tool and have identified a myriad of candidate markers associated in ovarian cancer. Although, this expression-based approach is intriguing, these studies alone can not distinguish the cancer “driving” genes that directly propel tumor progression from a

larger number of “passenger” genes that are concurrently overexpressed, but lack biological relevance in tumor development. This is because gene expression is dynamic and depends on both genetic and epigenetic programs in tumor cells. In contrast, molecular genetic changes, such as alterations in DNA copy number (e.g., amplifications and deletions), and point mutations are inheritable in nature and are the result of Darwinian selection because of the growth advantage conferred by these alterations in tumors (65). The success of the human genome database and sequence assembly has accelerated cancer genome studies, and it is providing precise data that will facilitate chromosomal mapping and localization of potential oncogenes and tumor suppressors. For example, recent development of innovative technologies, such as digital Karyotyping, array-based comparative genomic hybridization (CHG), and representational oligonucleotide microarray analysis (ROMA) provide molecular platforms that detect DNA copy-number changes at a genome-wide scale with excellent resolution (66). In addition, an automated capillary sequencing platform and other new techniques have become available for large-scale mutational analyses of human cancers. Many research groups have started to apply these new technologies to ovarian cancer with the expectation that they will facilitate the discovery of new tumor-related genes that play a casual role in the development of ovarian cancer.

The pathogenesis, behavior, and clinical management of ovarian borderline tumors, especially, the serous borderline tumors need to be defined. These gaps in the knowledge are largely because of the fact that most studies of SBTs are small, have short follow-up, and are from tertiary care centers. The few population-based studies that have been performed suffer from lack of a uniform pathology review, which results in misclassification as the diagnoses come from community hospitals where pathologists have limited experience with these tumors. In August 2003, an NIH/NCI workshop on ovarian borderline tumors concluded that much of the confusion and controversy surrounding these tumors were because of lack of population-based studies, in which tumors have been uniformly classified and lack of studies with long-term follow-up (67).

Mortality in patients with SBTs is limited to those with extraovarian disease, but the management of these patients remains controversial. Generally, women with noninvasive implants are followed conservatively whereas those with invasive implants are treated with chemotherapy. Unfortunately, some women with noninvasive implants develop recurrences, and invasive implants typically do not respond to conventional cytotoxic chemotherapy. Accordingly, new types of treatment are necessary for these tumors.

## 6. CONCLUSION

The pathogenesis of ovarian carcinoma, the most lethal gynecological malignancy, is unknown largely because of the lack of a tumor progression model. This chapter reviews a newly proposed pathogenesis model. In this model, surface epithelial tumors are divided into two broad categories designated type I and type II tumors, which correspond to two main pathways of tumorigenesis. Type I tumors tend to be low-grade neoplasms that arise in a stepwise fashion from borderline tumors, whereas type II tumors are high-grade neoplasms for which morphologically recognizable precursor lesions have not been identified, so-called “*de novo*” development. This model provides a morphological and molecular genetic framework for future studies aimed at elucidating the pathogenesis of ovarian cancer. Unraveling the complex molecular pathways in

the development of ovarian carcinomas will not only shed light on the pathogenesis of ovarian cancer, but will also provide the scientific basis for the development of new diagnostic tests and novel target-based therapy for this devastating disease.

## REFERENCES

1. Jemal A, Tiwari RC, Murray T, et al. Cancer statistics 2004. *CA Cancer J Clin* 2004; 54: 8–29.
2. Seidman JD, Russell P, Kurman RJ. Surface epithelial tumors of the ovary. Blaustein's pathology of the female genital tract. (Kurman RJ, ed.), New York, Springer Verlag, 2002, pp. 791–904.
3. Scully RE. International histological classification of tumors: histological typing of ovarian tumors. World Health Organization, Geneva, 1999.
4. Scully RE. World Health Organization international histological classification of tumours. New York, NY, Springer, 1999.
5. Dubeau L. Ovarian Cancer. The metabolic and molecular bases of inherited disease. (Scriver CR, Beaudet AL, Sly WS, et al., eds.), McGraw-Hill, 2001, pp. 1091–1096.
6. Berek JS, Martinez-Maza O. Molecular and biologic factors in the pathogenesis of ovarian cancer. *J Reprod Med* 1994; 39: 241–248.
7. Burks RT, Sherman ME, Kurman RJ. Micropapillary serous carcinoma of the ovary. A distinctive low-grade carcinoma related to serous borderline tumors. *Am J Surg Pathol* 1996; 20: 1319–1330.
8. Riopel MA, Ronnett BM, Kurman RJ. Evaluation of diagnostic criteria and behavior of ovarian intestinal- type mucinous tumors: atypical proliferative (borderline) tumors and intraepithelial, microinvasive, invasive, and metastatic carcinomas. *Am J Surg Pathol* 1999; 23: 617–635.
9. Seidman JD, Kurman RJ. Subclassification of serous borderline tumors of the ovary into benign and malignant types. A clinicopathologic study of 65 advanced stage cases. *Am J Surg Pathol* 1996; 20: 1331–1345.
10. Sehdev AES, Sehdev PS, Kurman RJ. Noninvasive and invasive micropapillary serous carcinoma of the ovary: a clinicopathologic analysis of 135 cases. *Am J Surg Pathol* 2003; 27: 725–736.
11. Okuda T, Otsuka J, Sekizawa A, et al. p53 mutations and overexpression affect prognosis of ovarian endometrioid cancer but not clear cell cancer. *Gynecol Oncol* 2003; 88: 318–325.
12. Modesitt SC, Tortolero-Luna G, Robinson JB, Gershenson D, Wolf JK. Ovarian and extraovarian endometriosis-associated cancer. *Obstet Gynecol* 2002; 100: 788–795.
13. Horiuchi A, Itoh K, Shimizu M, et al. Toward understanding the natural history of ovarian carcinoma development: a clinicopathological approach. *Gynecol Oncol* 2003; 88: 309–317.
14. Singer G, Kurman RJ, Chang H-W, Cho SKR, Shih I-M. Diverse tumorigenic pathways in ovarian serous carcinoma. *Am J Pathol* 2002; 160: 1223–1228.
15. Masuda A, Takeda A, Fukami H, Yamada C, Matsuyama M. Characteristics of cell lines established from a mixed mesodermal tumor of the human ovary. Carcinomatous cells are changeable to sarcomatous cells. *Cancer* 1987; 60: 1697–2703.
16. Moritani S, Moriya T, Kushima R, Sugihara H, Harada M, Hattori T. Ovarian carcinoma recurring as carcinosarcoma. *Pathol Int* 2001; 51: 380–384.
17. Bell DA, Scully RE. Early de novo ovarian carcinoma. A study of fourteen cases. *Cancer* 1994; 73: 1859–1864.
18. Peyssonnaud C, Eychene A. The Raf/MEK/ERK pathway: new concepts of activation. *Biol Cell* 2001; 93: 53–62.
19. Singer G, Oldt R 3rd, Cohen Y, et al. Mutations in BRAF and KRAS characterize the development of low-grade ovarian serous carcinoma. *J Natl Cancer Inst* 2003; 95: 484–486.
20. Davies H, Bignell GR, Cox C, et al. Mutations of the BRAF gene in human cancer. *Nature* 2002; 417: 949–954.
21. Rajagopalan H, Bardelli A, Lengauer C, Kinzler KW, Vogelstein B, Velculescu VE. Tumorigenesis: RAF/RAS oncogenes and mismatch-repair status. *Nature* 2002; 418: 934.
22. Ho C-L, Kurman RJ, Dehari R, Wang T-L, Shih I-M. Mutations of BRAF and KRAS precede the development of ovarian serous borderline tumors. *Cancer Res* 2004; 64: 6915–6918.
23. Chan W-Y, Cheung K-K, Schorge JO, et al. Bcl-2 and p53 Protein Expression, Apoptosis, and p53 Mutation in Human Epithelial Ovarian Cancers. *Am J Pathol* 2000; 156: 409–417.
24. Kohler MF, Marks JR, Wiseman RW, et al. Spectrum of mutation and frequency of allelic deletion of the p53 gene in ovarian cancer. *J Natl Cancer Inst* 1993; 85: 1513–1519.
25. Milner J, Medcalf EA, Cook AC. Tumor suppressor p53: analysis of wild-type and mutant p53 complexes. *Mol Cell Biol* 1991; 11: 12–19.

26. Kupryjanczyk J, Thor AD, Beauchamp R, et al. p53 gene mutations and protein accumulation in human ovarian cancer. *Proc Natl Acad Sci USA* 1993; 90: 4961–4965.
27. Berchuck A, Carney M. Human ovarian cancer of the surface epithelium. *Biochem Pharmacol* 1997; 54: 541–544.
28. Wen WH, Reles A, Runnebaum IB, et al. p53 mutations and expression in ovarian cancers: correlation with overall survival. *Int J Gynecol Pathol* 1999; 18: 29–41.
29. Shelling AN, Cooke I, Ganesan TS. The genetic analysis of ovarian cancer. *Br J Cancer* 1995; 72: 521–527.
30. Pothuri B, Leitao M, Barakat R, et al. Genetic analysis of ovarian carcinoma histogenesis. Abstract in Society of Gynecologic Oncologists, 32nd Annual Meeting 2001. Nashville, TN.
31. Gallardo A, Matias-Guiu X, Lagarda H, et al. Malignant mullerian mixed tumor arising from ovarian serous carcinoma: a clinicopathologic and molecular study of two cases. *Int J Gynecol Pathol* 2002; 21: 268–272.
32. Kounelis S, Jones MW, Papadaki H, Bakker A, Swalsky P, Finkelstein SD. Carcinosarcomas (malignant mixed mullerian tumors) of the female genital tract: comparative molecular analysis of epithelial and mesenchymal components. *Hum Pathol* 1998; 29: 82–87.
33. Abeln EC, Smit VT, Wessels JW, de Leeuw WJ, Cornelisse CJ, Fleuren GJ. Molecular genetic evidence for the conversion hypothesis of the origin of malignant mixed mullerian tumours. *J Pathol* 1997; 183: 424–431.
34. Sreenan JJ, Hart WR. Carcinosarcomas of the female genital tract. A pathologic study of 29 metastatic tumors: further evidence for the dominant role of the epithelial component and the conversion theory of histogenesis. *Am J Surg Pathol* 1995; 19: 666–674.
35. Ross JS, Yang F, Kallakury BV, Sheehan CE, Ambros RA, Muraca PJ. HER-2/neu oncogene amplification by fluorescence in situ hybridization in epithelial tumors of the ovary. *Am J Clin Pathol* 1999; 111: 311–316.
36. Cheng JQ, Godwin AK, Bellacosa A, et al. AKT2, a putative oncogene encoding a member of a subfamily of protein- serine/threonine kinases, is amplified in human ovarian carcinomas. *Proc Natl Acad Sci USA* 1992; 89: 9267–9271.
37. Bellacosa A, de Feo D, Godwin AK, et al. Molecular alterations of the AKT2 oncogene in ovarian and breast carcinomas. *Int J Cancer* 1995; 64: 280–285.
38. Shih IM, Sheu J, Santillan A, et al. Amplification of a chromatin remodeling gene, Rsf-1/HBXAP, in ovarian carcinoma. *Proc Natl Acad Sci USA* 2005; 102: 14,004–14,009.
39. Singer G, Rebmann V, Y-C C, Chen et al. HLA-G is a potential tumor marker in malignant ascites. *Clin Cancer Res* 2003; 9: 4460–4464.
40. Chen Y-C, Pohl G, Wang T-L, et al. Apolipoprotein E is required for cell proliferation and survival in ovarian cancer. *Cancer Res* 2005; 65: 331–337.
41. Urošević M, Kurrer MO, Kamarashev J, et al. Human leukocyte antigen G up-regulation in lung cancer associates with high-grade histology, human leukocyte antigen class I loss and interleukin-10 production. *Am J Pathol* 2001; 159: 817–824.
42. Urošević M, Willers J, Mueller B, Kempf W, Burg G, Dummer R. HLA-G protein up-regulation in primary cutaneous lymphomas is associated with interleukin-10 expression in large cell T-cell lymphomas and indolent B-cell lymphomas. *Blood* 2002; 99: 609–617.
43. Tsuchiya A, Sakamoto M, Yasuda J, et al. Expression profiling in ovarian clear cell carcinoma: identification of hepatocyte nuclear factor-1beta as a molecular marker and a possible molecular target for therapy of ovarian clear cell carcinoma. *Am J Pathol* 2003; 163: 2503–2512.
44. Hough CD, Sherman-Baust CA, Pizer ES, et al. Large-scale serial analysis of gene expression reveals genes differentially expressed in ovarian cancer. *Cancer Res* 2000; 60: 6281–6287.
45. Mok SC, Bell DA, Knapp RC, et al. Mutation of K-ras protooncogene in human ovarian epithelial tumors of borderline malignancy. *Cancer Res* 1993; 53: 1489–1492.
46. Ichikawa Y, Nishida M, Suzuki H. Mutation of KRAS protooncogene is associated with histological subtypes in human mucinous ovarian tumors. *Cancer Res* 1994; 54: 33–35.
47. Enomoto T, Weghorst CM, Inoue M, Tanizawa O, Rice JM. K-ras activation occurs frequently in mucinous adenocarcinomas and rarely in other common epithelial tumors of the human ovary. *Am J Pathol* 1991; 139: 777–785.
48. Caduff RF, Svoboda-Newman SM, Ferguson AW, Johnston CM, Frank TS. Comparison of mutations of Ki-RAS and p53 immunoreactivity in borderline and malignant epithelial ovarian tumors. *Am J Surg Pathol* 1999; 23: 323–328.

49. Gemignani ML, Schlaerth AC, Bogomolny F, et al. Role of KRAS and BRAF gene mutations in mucinous ovarian carcinoma. *Gynecol Oncol* 2003; 90: 378–381.
50. Wu R, Zhai Y, Fearon ER, Cho KR. Diverse mechanisms of beta-catenin deregulation in ovarian endometrioid adenocarcinomas. *Cancer Res* 2001; 61: 8247–8255.
51. Moreno-Bueno G, Gamallo C, Perez-Gallego L, deMora JC, Suarez A, Palacios J. beta-Catenin expression pattern, beta-catenin gene mutations, and microsatellite instability in endometrioid ovarian carcinomas and synchronous endometrial carcinomas. *Diagn Mol Pathol* 2001; 10: 116–122.
52. Cuatrecasas M, Erill N, Musulen E, Costa I, Matias-Guiu X, Prat J. K-ras mutations in nonmucinous ovarian epithelial tumors: a molecular analysis and clinicopathologic study of 144 patients. *Cancer* 1998; 82: 1088–1095.
53. Hogdall EV, Hogdall CK, Blaakaer J, et al. K-ras alterations in Danish ovarian tumour patients. From the Danish “Malova” Ovarian Cancer study. *Gynecol Oncol* 2003; 89: 31–36.
54. Obata K, Morland SJ, Watson RH, et al. Frequent PTEN/MMAC mutations in endometrioid but not serous or mucinous epithelial ovarian tumors. *Cancer Res* 1998; 58: 2095–2097.
55. Sato N, Tsunoda H, Nishida M, et al. Loss of heterozygosity on 10q23.3 and mutation of the tumor suppressor gene PTEN in benign endometrial cyst of the ovary: possible sequence progression from benign endometrial cyst to endometrioid carcinoma and clear cell carcinoma of the ovary. *Cancer Res* 2000; 60: 7052–7056.
56. Saito M, Okamoto A, Kohno T, et al. Allelic imbalance and mutations of the PTEN gene in ovarian cancer. *Int J Cancer* 2000; 85: 160–165.
57. Thomas EJ, Campbell IG. Molecular genetic defects in endometriosis. *Gynecol Obstet Invest* 2000; 50: 44–50.
58. Obata K, Hoshi H. Common genetic changes between endometriosis and ovarian cancer. *Gynecol Obstet Invest* 2000; 50: 39–43.
59. Bischoff FZ, Simpson JL. Heritability and molecular genetic studies of endometriosis. *Hum Reprod Update* 2000; 6: 37–44.
60. Dinulescu DM, Ince TA, Quade BJ, Shafer SA, Crowley D, Jacks T. Role of K-ras and Pten in the development of mouse models of endometriosis and endometrioid ovarian cancer. *Nat Med* 2005; 11: 63–70.
61. Francis-Thickpenny KM, Richardson DM, van Ee CC, et al. Analysis of the TGF-beta functional pathway in epithelial ovarian carcinoma. *Br J Cancer* 2001; 85: 687–691.
62. Fujita M, Enomoto T, Yoshino K, et al. Microsatellite instability and alterations in the hMSH2 gene in human ovarian cancer. *Int J Cancer* 1995; 64: 361–366.
63. Gras E, Catus L, Arguelles R, et al. Microsatellite instability, MLH-1 promoter hypermethylation, and frameshift mutations at coding mononucleotide repeat microsatellites in ovarian tumors. *Cancer* 2001; 92: 2829–2836.
64. Shih I-M, Kurman RJ. Ovarian tumorigenesis- a proposed model based on morphological and molecular genetic analysis. *Am J Pathol* 2004; 164: 1511–1518.
65. Kinzler KW, Vogelstein B. *The Genetic Basis of Human Cancer*. Toronto, McGraw-Hill, 2002.
66. Shih Ie M, Wang TL. Apply innovative technologies to explore cancer genome. *Curr Opin Oncol* 2005; 17: 33–38.
67. Berman JJ. Borderline Ovarian Tumor Workshop, Bethesda, Maryland, August 27–28, 2003. *Hum Pathol* 2004; 35: 907–909.
68. Singer G, Shih Ie M, Truskinovsky A, Umudum H, Kurman RJ. Mutational Analysis of K-ras Segregates Ovarian Serous Carcinomas into Two Types: Invasive MPSC (Low-grade Tumor) and Conventional Serous Carcinoma (High-grade Tumor). *Int J Gynecol Pathol* 2003; 22: 37–41.

# 3

---

## Molecular Markers in Epithelial Ovarian Cancer

---

*Pat J. Morin, PhD*

### CONTENTS

INTRODUCTION  
EARLY STAGE DETECTION OF OVARIAN CANCER  
MARKERS FOR OVARIAN CANCER PROGNOSIS, OUTCOME,  
OR DRUG RESISTANCE  
CONCLUSIONS  
REFERENCES

---

### 1. INTRODUCTION

More than 50% of the women diagnosed with epithelial ovarian cancer will succumb to their disease. This high death rate is because of two substantial clinical problems:

1. A typically late detection of the disease.
2. The common resistance of ovarian tumors to current therapeutic strategies.

Indeed, the 5-year survival rate of patients with stage I disease is more than 90%, whereas patient diagnosed with stage III or IV disease have lower than a 30% survival rate (1). Unfortunately, because of the lack of distinctive symptoms and reliable biomarkers, the vast majority of ovarian cancer patients are diagnosed with late stage disease. In addition, at diagnosis, about half the tumors are intrinsically resistant to chemotherapy, and up to half of the tumors initially responsive will develop resistance. Clearly, identification of biomarkers useful in early detection would have a significant impact on cancer survival. Moreover, the existence of markers that would be predictive of outcome may allow for improved, more targeted therapy. In this chapter, recent advances in the identification of biomarkers applicable to detection and prognosis (molecular correlates) of epithelial ovarian cancer will be discussed. Because sporadic ovarian cancer represents more than 90% of all the cases, concentration will be on sporadic cancers as opposed to hereditary cancers, which arise in families at risk (such as *BRCA1/2* families).

### 2. EARLY STAGE DETECTION OF OVARIAN CANCER

Because of the fact that ovarian cancer is relatively rare in the general population, (incidence of 16 cases per 100,000 women per year), any screening method must have

From: *Current Clinical Oncology: Molecular Pathology of Gynecologic Cancer*  
Edited by: A. Giordano, A. Bovicelli, and R. Kurman © Humana Press Inc., Totowa, NJ

an extremely high specificity in order to avoid detecting a large number of false-positives. For example, a screening test with a specificity of 99% and a sensitivity of 99% would detect approx 30 false-positives for each real case of ovarian cancer, leading to a positive predictive value of only 3–5%. For these reasons, it is accepted that a good ovarian cancer marker will require a specificity of more than 99.6% to achieve any clinical relevance for screening of the general population (2). On the other hand, in high-risk populations, screening tests with inferior sensitivity and specificity may still be useful. Generally, it is now believed that the ideal test will be multiparametric, involving multiple different markers or detection techniques (3).

### 2.1. CA 125/*Muc16*

An antibody that reacted with an ovarian cancer antigen was identified almost 25 years ago (4) and named OC125. The recognized antigen, a glycoprotein initially named CA 125, was found to be shed into culture supernatant and a serum-based radioimmunoassay was quickly developed (5). Cloning the *CA 125* gene turned out to be extremely difficult, but the feat was finally accomplished in 2001 and the complementary DNA was found to have striking similarities to mucin molecules. For this reason, the gene encoding CA 125 was named *MUC16*. Because the CA 125 protein is secreted, it was hypothesized early that a blood test based on this protein may be useful for early detection of ovarian cancer.

The serum CA 125 assay has been evaluated for ovarian cancer screening, as a tool to differentiate benign from malignant ovarian masses, and as an indicator of tumor status during and after chemotherapy (6,7). Using the assay, it was initially shown that 99% of healthy women have less than 35 U/mL CA 125, whereas 82% of sera from women with epithelial ovarian cancer had levels higher than 35 U/mL (5). Interestingly, in 90% of the cases, levels of CA 125 corresponded to tumor volume when studied longitudinally. CA 125 has also been observed elevated in a variety of benign diseases, including endometriosis. Unfortunately, CA 125 is typically not sufficiently specific or sensitive for screening of the general population. For example, only 50% of stage I patients have CA 125 higher than 35 U/mL (8). In addition, benign gynecological conditions can lead to unacceptably high levels of false-positive tests (low specificity) in premenopausal women, although this problem is less significant in postmenopausal women.

It has been suggested that combining CA 125 with other screening methods, such as transvaginal ultrasonography may improve specificity (9), but the results did not reach the levels that would allow for screening of the general population. It has been suggested that monitoring CA 125 levels in patients for a period of time may lead to improved sensitivity for early detection by providing a baseline and clarifying trends (10,11). However, it is believed that up to 20% of ovarian cancers do not express CA 125, suggesting a maximum theoretical sensitivity of 80% for this marker, regardless of the improvement on detection. It is likely that the theoretical sensitivity of CA 125 for early stage ovarian will be smaller, possibly down to 50%. In addition, the relatively low specificity would lead to many false-positive and a large number of unnecessary surgeries. Combining CA 125 with other markers, such as CA19-9, CA72-4, and CA15-3 has been shown to improve sensitivity of detection (12).

The use of CA 125 as a marker might be most useful in monitoring recurrent ovarian cancer (13). It has indeed been observed that CA 125 tracks disease accurately



in more than 80% of ovarian cancer patients. However, this aspect of CA 125 as a biomarker is more relevant to the next section dealing with prognosis factors and will be discussed later.

### ***2.2. He4/Whey Acidic Protein (WAP)-Type Four-Disulfide Core2***

From the beginning of the gene-expression profiling era, it was hypothesized that detailed knowledge of gene expression in cancer might lead to the identification of candidate tumor markers. Microarrays, serial analysis of gene expression, and EST analysis have been used to study a variety of human tumors, including ovarian cancer. HE4/WAP-type four-disulfide core (WFDC)2 was one of the first new ovarian cancer candidates identified using complementary DNA arrays (14,15). This finding was confirmed soon afterwards using serial analysis of gene expression (16). HE4/WFDC2 contains two WFDC domains, which are known to function as protease inhibitors, although no protease inhibition activity has yet been identified for HE4. A blinded study with ovarian cancer patients and controls recently demonstrated that HE4 has similar specificity and sensitivity as CA 125, although the HE4/WFDC2 assay appeared to be less likely to yield false-positive in patients with nonmalignant diseases (17). Therefore, HE4/WFDC2, in combination with CA 125 or other markers may represent a promising approach for general screening of the population (18). Screening trials are currently being conducted to investigate this possibility.

### ***2.3. Kallikreins***

The kallikreins family of serine proteases includes 15 members, which share significant homology, but whose exact physiological functions remain unknown (19). Many members of the kallikrein family have altered expression in ovarian and other cancers. Interestingly, hK3, also known as prostate specific antigen has been widely used for prostate cancer screening and is probably the most useful tumor marker to date. Recently, it has been hypothesized that certain members of the kallikrein family might also be useful for ovarian cancer screening. Specifically, hK6 (20), hK10 (21), and hK11 (22) have all been shown to be elevated in the serum of a majority of ovarian cancer patients. Interestingly, the sensitivity of hK6 and hK10 for early stage (stages I and II) was found to be approx 25% (at 90% specificity), but this figure could be increased to more than 90% when combined with CA 125 (20,21). However, large and detailed clinical studies with exact sensitivity and specificity figures still need to be done. As suggested earlier, because hKs may have different patterns of expression compared with CA 125, a test combining both types of markers might be useful.

### ***2.4. Proteomics and Serum Patterns***

Recently, it was suggested that proteomics patterns in serum may be useful in ovarian cancer detection. A study utilizing mass spectrometry identified protein patterns in the serum of women with ovarian cancer and compared these patterns with those observed in healthy women (23). A specific protein pattern was identified that was capable of recognizing ovarian cancer in a population of women at risk with a sensitivity of 100% and a specificity of 95%, which is probably not sufficient for screening of the general population. It is worth noting that the exact identities of the proteins making up the “pattern” are unknown. Therefore, it is unclear whether the proteins making

up the pattern are produced by the tumor itself or by a host reaction to the tumor. In this case, the results may not be specific for ovarian cancer or even for cancer at all. Another weakness is that the validation in the initial paper was performed on cancers from “at risk” women, and it is unclear whether sporadic ovarian cancers will yield the same pattern, because they are known to have quite a different biology. Finally, the specificity of the assay is not sufficient for screening of the general population. Although, in its infancy, this is a promising approach that may eventually be useful in the detection of ovarian or other cancers.

Another proteomics approach identified specific proteins that are altered in the serum of women with ovarian cancer (24). In that study, three proteins were found to be differentially expressed in the serum (ApoA1 [decreased]; truncated transthyretin [decreased]; a fragment of a-trypsin inhibitor heavy chain H4 [elevated]). When combined with CA 125, these three biomarkers lead to a significant improvement in sensitivity more than CA 125, demonstrating again that combining biomarkers can indeed be desirable. However, the sensitivity of 74% (at a specificity of 97%) was still insufficient for this approach to be successfully applied to the general population.

### ***2.5. Others Markers and Combinations of Markers***

Large-scale gene-expression methods have identified many genes that are overexpressed in ovarian cancer (14–16,25–45). These data have provided a wealth of candidates that may be useful as potential tumor markers, especially, the genes that are known to encode secreted proteins. The candidates identified independently by multiple studies are particularly promising. Among genes encoding secreted proteins, HE4, osteopontin, SLPI, and SPINT1 were identified by multiple studies as upregulated in ovarian cancer (46). These candidates are currently being evaluated by various groups for their potential as screening markers. In addition, many membrane proteins identified by multiple studies may also be useful in diagnosis and therapy. These candidates include Ep-CAM, MUC1, SPINT2, CD9, CLDN3, CLDN4, and HER3.

Because it appears that no single marker is elevated and secreted in all ovarian cancers, it is likely that a combination of markers will be necessary to detect a majority of ovarian cancers. In addition, biomarker-based test may be combined with other techniques, such as transvaginal sonography to attain yet higher specificities and sensitivities (3). As mentioned earlier, a combination of CA 125, CA19-9, CA72-4, and CA15-3 has been shown to improve sensitivity, but the usefulness of the added markers was restricted to initial diagnosis. Thus, it did not provide any advantage in the follow-up and detection of recurrent disease. In addition, using immunohistochemistry, a recent study demonstrated that a combination of four markers (CLDN3, CA 125, MUC1, and VEGF) could identify all 158 ovarian cancers tested, including eight early stage serous cancers (45). It remains to be seen whether this combination of proteins will also be useful when adapted to a blood test for screening the general population.

## **3. MARKERS FOR OVARIAN CANCER PROGNOSIS, OUTCOME, OR DRUG RESISTANCE**

Because of the wide variability in the clinical outcome of ovarian cancer patients, it is clear that the identification of molecular markers that could predict overall survival or response to chemotherapy with better accuracy than the classical prognosis factors

(tumor grade, stage, and so on) might be of significant clinical value. For example, the identification of patients with tumors that have a high probability of developing resistance to conventional chemotherapy might make these patients ideal candidates for alternative or novel therapeutic regimens. In this section, the major molecular markers that have been investigated as possible ovarian cancer prognostic factors are reviewed.

### 3.1. Cell-Cycle Regulators

Cancers are characterized by aberrant proliferation resulting from alterations in cell-cycle regulatory mechanisms. In addition, many oncogenes and tumor suppressor genes have been implicated in pathways regulating the cell cycle, providing a direct mechanistic link between cell-cycle control and tumorigenesis. On the other hand, it is unclear whether any of the cell-cycle components can be used as tumor marker for prognosis. In this section, the current data on the main cell-cycle regulators investigated for their prognostic value in ovarian cancer will be reviewed.

#### 3.1.1. *p53*

The *p53* gene encodes a nuclear phosphoprotein that can bind specific DNA sequences and function as a transcription factor to positively or negatively regulate the transcription of other growth regulatory genes. *p53* is involved in cell-cycle control, DNA damage response, stress response, cell senescence, genomic stability, and apoptosis (47). *p53* is mutated in the germline of Li-Fraumeni patients, a cancer predisposition syndrome and it is believed to be one of the most commonly mutated genes in human cancer, as it is found somatically altered in about 50% of all cancers (48–50). Most missense mutations in *p53* appear to change the conformation of the protein, leading to increased stability and higher steady-state levels. Indeed, a close correlation between *p53* immunoreactivity and *p53* mutation has been shown (51).

Soon after the realization that *p53* was a major player in human cancer, ovarian cancer was also shown to frequently overexpress the *p53* protein and contained mutations in at least 50% of the cases, regardless of stage (52–55). A large number of studies have investigated the prognostic ability of *p53* mutations and/or overexpression in ovarian cancer. There is no consensus on the predictive value of *p53* in the literature. *p53* has been shown to be predictive of overall survival by many groups (56–79). However, when analyzed by multivariate analysis, few of these studies found that *p53* was an independent prognostic marker (58,61,64–66,70,71,74,76,77). On the other hand, a large number of reports have found no predictive value at all for *p53* (53,68,80–96). It has been shown that, in certain cases, *p53* status can be predictive of response to chemotherapy, and could therefore be useful in tailoring treatment to individual patients (60,62,66,67,97–101). *p53* may therefore have a role in determining the sensitivity of ovarian tumors to chemotherapy. This would be consistent with the role of *p53* in DNA damage. However, as is the case for survival, many studies have showed that *p53* status does not appear to affect the response to chemotherapy (56,64,68,74,83,85,89,94,102). Table 1 summarizes these findings.

Overall, because of the lack of reproducibility in various studies, it has been concluded that *p53* does not represent a robust marker for prediction of either survival or response to chemotherapy. The lack of reproducibility may be attributed to several factors, such as difference in the patient cohort (sample size, differences in treatment, grade, and so on) and different techniques for *p53* alteration detection (mutation vs

**Table 1**  
**Studies Evaluating the Prognostic Value of p53**

<i>Exp/mut</i>	<i>Cases</i>	<i>Positive (%)</i>	<i>Prognosis</i>	<i>Survival</i>		<i>Chemotherapy</i>		<i>References</i>
				<i>Univariate</i>	<i>Multivariate</i>	<i>Univariate</i>	<i>Multivariate</i>	
Exp	107	50	No	No				53
Exp	52	29	No	No	No			80
Mut	38	79	No	No	No			87
Exp	38	68	No	No	No			87
Exp	94	50	No	No	No			91
Mut	67	26	No	No	No			92
Exp	55	68	Yes	Yes	No			73
Exp	100		Yes	Yes	No			140
Exp	284	62	Yes	Yes	No			79
Exp	93	35	Yes	Yes	No	No		56
Exp	90	43	Yes	Yes	No			57
Exp	136	44	Yes	Yes	Yes			58
Exp	110	36	Yes	Yes	Yes			59
Exp	61	42	Yes	Yes	Yes	No		74
Exp	33	60	Yes	Yes	Yes	Yes		100
Mut	33	60	Yes	Yes	Yes	Yes		100
Exp	179	44	No	No	No			81
Mut/exp	61	61	No	No	No			93
Exp	83		Yes	Yes	Yes			102
Exp	141	47	Yes	Yes	No	No		62
Mut	68	61	Yes	Yes	Yes	Yes		60
Exp	68	51	Yes	Yes	No	Yes		60
Exp	221	48	No	No	No	Yes		82
Exp	83	29	Yes	Yes	Yes			61
Exp	347	50	Yes	Yes	No			78
Mut	45		No	Yes	No	No	No	94

Exp	187	14	Yes	Yes	Yes	Yes	Yes	Yes	Yes	Yes	Yes	97
Exp	185	49	Yes	Yes	Yes	Yes	Yes	Yes	Yes	No	No	64
Exp	168	57	Yes	No	No	No	No	No	Yes	Yes	Yes	99
Exp	316	34	Yes	Yes	Yes	Yes	Yes	No	No	No	No	63
Exp	85	62	Yes	Yes	Yes	Yes	Yes	No	No	No	No	75
Exp	54	61	No	No	No	No	No	No	No	No	No	109
Exp	43		Yes	Yes	Yes	Yes	Yes	Yes	Yes	Yes	Yes	128
Mut	130	72	Yes	Yes	Yes	Yes	Yes	Yes	Yes	Yes	Yes	65
Mut/exp	171	57/49	Yes	Yes	Yes	Yes	Yes	Yes	Yes	Yes	Yes	77
Exp	66	58	Yes	Yes	No	No	No	No	No	Yes	Yes	98
Mut/Exp	43	53/70	No	No	No	No	No	No	No	No	No	85
Exp	120	Continuum	Yes	Yes	Yes	Yes	Yes	Yes	Yes	Yes	Yes	66
Mut/exp	48	60	Yes	Yes	Yes	Yes	Yes	Yes	Yes	Yes	Yes	103
Mut	73	44	No	No	No	No	No	No	No	No	No	83
Mut	102	39	No	No	No	No	No	No	No	No	No	68
Exp	102	44	Yes	Yes	Yes	Yes	Yes	Yes	Yes	Yes	Yes	68
Exp	103		Yes	Yes	Yes	Yes	Yes	Yes	Yes	Yes	Yes	108
Exp	178	62	Yes	Yes	Yes	Yes	Yes	No	No	Yes	No	67
Mut	178	56	Yes	Yes	Yes	Yes	Yes	No	No	Yes	Yes	67
Exp	50	66	No	No	No	No	No	No	No	No	No	84
Exp	31	48	Yes	Yes	Yes	Yes	Yes	?	?	?	?	69
Exp	109	36	Yes	Yes	Yes	Yes	Yes	Yes	Yes	Yes	Yes	70
Exp	69	49	No	No	No	No	No	No	No	No	No	86
Exp	204	61	No	No	No	No	No	No	No	No	No	89
Exp	134	25	Yes	Yes	Yes	Yes	Yes	No	No	Yes	Yes	101
Exp	229	59	No	No	No	No	No	No	No	No	No	90
Exp	125	66	No	No	No	No	No	No	No	No	No	95
Mut	267	47	No	No	No	No	No	No	No	No	No	88
Exp	73	67	Yes	Yes	Yes	Yes	Yes	Yes	Yes	Yes	Yes	76
Mut	125	77	Yes	Yes	No	No	No	No	No	No	No	95
Mut/exp	178	40/33	No	No	No	No	No	No	No	No	No	96
Exp	868	47	Yes	Yes	Yes	Yes	Yes	Yes	Yes	No	No	72
Exp	134	79	Yes	Yes	Yes	Yes	Yes	Yes	Yes	Yes	Yes	71

overexpression, different antibodies). For example, it has been shown that in a given population of ovarian cancer patients, IHC with some p53 antibodies can have prognostic value, whereas other antibodies could not (76). In addition, although, p53 expression is a good marker of mutation, it is not perfectly correlated (96). This was also demonstrated by the fact that the study of overexpression as compared with mutation of p53 sometimes leads to inconsistent results with respect to prediction, within a given tumor sample (67,68,103).

Although, clearly not a reproducibly strong prognostic factor, p53 has been shown to have the potential to divide tumors into categories for which excellent prognostic factors can be found. For example, p21 appears to be an excellent predictor of survival among tumors that do not express p53 (89). Other examples of this have been reported and will be discussed in the appropriate sections later.

### 3.1.2. p21 (CDKN1A GENE)

CDKN1A encodes a potent cyclin-dependent kinase inhibitor. The p21 protein binds with and inhibits the activity of cyclin-CDK2 or -CDK4 complexes, and thus, functions as a regulator of cell-cycle progression at G<sub>1</sub> (104). The expression of CDKN1A is controlled, among other factors, by the tumor suppressor protein p53, through which the p21 can mediate the p53-dependent cell-cycle G<sub>1</sub> phase arrest in response to a variety of stresses. The majority of the studies published so far have not found a correlation between p21 protein expression and ovarian cancer outcome (66,68,75,76,98,105,106), although some studies have found that reduced p21 expression was associated with reduced survival in multivariate analysis (71,107). p21 appeared particularly useful among p53-negative tumors (89,108), but this was clearly not always the case (66). In addition, p21 could not generally predict response to chemotherapy (66,68), but at least one study reported some predictive value for p21 with respect to platinum sensitivity (89).

### 3.1.3. p27 (CDKN1B)

CDKN1B encodes a cyclin-dependent kinase inhibitor, p27, which shares limited similarity with CDK inhibitor p21. The encoded protein binds with and prevents the activation of cyclin E-CDK2 or cyclin D-CDK4 complexes, and thus, controls the cell-cycle progression at G<sub>1</sub> (104). In contrast to what has been observed for p21, p27 shows promise as a prognostic marker. Indeed, the vast majority of the studies published so far have suggested a predictive value for p27 expression where decreased p27 was associated with poor survival (71,89,109-113). Some studies failed to identify a prognostic value for p27 (105,107), but these studies are clearly in the minority and, at this juncture, p27 represents a promising prognosis factor in ovarian cancer.

### 3.1.4. p16 (CDKN2A) AND OTHER CDKIS

CDKN2A encodes p16, a cyclin-dependent kinase inhibitor specific for CDK4 and thereby involved in regulating the progression of the cell cycle through G<sub>1</sub> (104). Overall, p16 expression does not appear to be an independent prognostic marker in ovarian cancer (71,107,114,115), although p16 methylation (116) and p16 deletion (117) have been associated with disease progression or survival. One study has also found high p16 expression to be associated with lower survival (118). Other CDKs, such as p14 and p57 (Kip2) have also been studied in ovarian cancer, but were not found to provide prognostic information (76,119), although one study reported predictive value for p57 (120).

### 3.1.5. CYCLINS

Cyclin D1 forms a complex with and functions as a regulatory subunit of CDK4 or CDK6, whose activity is required for cell-cycle G<sub>1</sub>/S transition. A number of studies have found that cyclin D1 can be an independent prognostic marker in ovarian cancer (71,121,122). However, the real value of Cyclin D1 as a marker remains unclear, as several studies have failed to find predictive value for this protein (86,114,119,123).

Cyclin E is another protein that is important for progression of the cell cycle that has been implicated in various cancers. It forms a complex with and functions as a regulatory subunit of CDK2, whose activity is required for cell-cycle G<sub>1</sub>/S transition (104). This protein accumulates at the G<sub>1</sub>-S phase boundary and is degraded as cells progress through S phase. Again, similar to cyclin D1 findings, the results have been inconsistent as some studies report that cyclin E has predictive value for ovarian cancer prognosis (119,124), whereas other studies find no predictive value (71,107).

### 3.1.6. pRB

The pRB protein is important in controlling transcriptional mechanisms that mediate the progression of the cell cycle through the first parts of the G<sub>1</sub> phase. The transcriptional effects of Rb are mediated through its ability to repress transcription factors, such as E2F that are required for the expression of genes important for cell-cycle progression. Phosphorylation of pRB by cyclin D1/CDK4, cyclin E/CDK2, or cyclin A/CDK2 is essential for progression through the cell cycle, whereas hypophosphorylated Rb can lead to cell-cycle arrest. Although, the roles of Rb in controlling cell cycle are crucial, its relevance as a prognosis marker in ovarian cancer has not been demonstrated. Some studies have found predictive prognostic value for pRb (62,76,107), but many others have not (71,86,114,125).

## 3.2. Apoptosis

Because of the importance of apoptotic mechanisms in tumorigenesis (for survival in the absence of appropriate factors and during chemotherapy, for example), it has been hypothesized that the expression of various apoptotic proteins may have prognostic significance in ovarian and other cancers.

### 3.2.1. BCL-2 FAMILY

*Bcl-2* is a protooncogene implicated in cell survival through inhibition of apoptosis. Bax and bcl-x are members of the Bcl-2 family, which can counteract the ability of bcl-2 to inhibit apoptosis. Although, most studies show an absence of an overall survival predictive value for Bcl-2 (59,64,68,70,90,98,126,127) and Bax (70,90,126,127), there is evidence that both proteins used in conjunction can have prognostic significance (127). Bcl-2 was found to be a significant prognostic marker (expression of Bcl-2 was associated with improved survival) (64,74). In addition, perhaps surprisingly, expression of these apoptotic proteins is not always associated with a better response to chemotherapy (68,127), although association with response to chemotherapy has been reported for Bcl-2 (90,128) and Bax (98).

### 3.2.2. SURVIVIN

Survivin is an apoptosis inhibitor protein that interacts with the processed form of caspase-3 and inhibits its proteolytic activity, thereby preventing cell death. There have been suggestions that surviving expression might be a prognostic factor in cancer.

Although, survivin was frequently overexpressed in ovarian cancer and may represent a promising target for therapy, it does not appear to be of prognostic value (129,130), despite one study finding a correlation between survivin expression and overall survival (131).

### 3.3. CA 125

As mentioned earlier, CA 125 has shown promise for early detection of ovarian cancer and detection of recurrence. The rate of decline of CA 125 during chemotherapy has also been shown to be a potential prognostic marker. Several reviews have been written on the topic (13,132) and interested readers are referred to these reviews for a detailed discussion.

### 3.4. *ErbB2 (Her2/Neu)*

ERBB2 is a member of the epidermal growth factor receptor family of receptor tyrosine kinases. Activation of this receptor activates downstream signaling pathways, such as those involving mitogen-activated protein kinase, phosphatidylinositol-3 kinase, and angiogenic pathways (133). Amplification and overexpression of ERBB2 is seen in up to a third of ovarian tumors. ERBB2 signaling has been shown to be important in ovarian cancer development. However, ERBB2 overexpression does not appear to be an independent prognostic factor of ovarian cancer patients (72,134–142), although some studies have found that it could independently predict survival in some cases (143–145). Experiments have demonstrated that ERBB2 expression does not appear to affect the response to conventional, cytotoxic therapy (146). However, because a significant proportion of ovarian cancers expresses this protein, therapeutic strategies aimed at inhibiting this receptor, represent a promising approach and may reverse the malignancy induced by HER2/Neu overexpression (147). The monoclonal antibodies Herceptin and Iressa, for example, are currently being investigated for this purpose.

### 3.5. *Kallikreins*

Kallikreins have been found overexpressed or underexpressed in various cancers (19). The early investigations of kallikreins in ovarian cancer have been extremely promising. Indeed, multiple kallikreins (hK4–15) have been shown to be independent prognostic factors in ovarian cancer (20,21,148–162). The results are summarized in Table 2. The expression of certain kallikreins, such as hK8, hK9, hK11, hK13, and hK14, was associated with favorable prognosis (149,151–153,160–162), whereas others, such as hK4, hK5, hK6, hK10, and hK15 were associated with poor prognosis (20,21,148,154,156–159). Interestingly, hK4 expression has been associated with taxol resistance (155). It will be important to continue investigating these very promising markers to determine whether they can be useful in the clinic.

### 3.6. *Gene-Expression Patterns*

As the processes important in tumor initiation, progression, and development of drug resistance have been shown to be multifactorial and involve multiple molecular pathways, it is likely that overall gene-expression profiles will represent a powerful tool for identifying subset of tumors with particular behavior. For example, several studies performed in the last 4 or 5 years have demonstrated the power of microarrays



**Table 2**  
**Prognostic Value of Kallikreins**

<i>Protein</i>	<i>Detection method</i>	<i>Prognosis</i>	<i>Univariate</i>	<i>Multivariate</i>	<i>Reference</i>
hK4	IHC	Drug resistance	Yes	?	155
hK4	Reverse transcriptase polymerase chain reaction (RT-PCR)	Unfavorable	Yes	No	156
hK5	Immunoassay	Unfavorable	Yes	Yes, weak	157
hK5	RT-PCR	Unfavorable	Yes	Grade I, II	158
hK6	Immunoassay	Unfavorable	Yes	Yes	20
hK6	IHC	Unfavorable	Yes	Yes	159
hK8	RT-PCR	Favorable	Yes	No	160
hK8	RT-PCR	Favorable	Yes	Yes	161
hK9	RT-PCR	Favorable	Yes	Yes	162
hK10	Immunoassay	Unfavorable	Yes	Yes	21
hK10	Immunoassay	Unfavorable	Yes	Yes, stage III, IV	148
hK11	Immunoassay	Favorable	Yes	Yes	149
hK11	RT-PCR	Unfavorable	Yes	Yes	150
hK11	Immunoassay	Favorable	Yes	Yes	151
hK13	Immunoassay	Favorable	Yes	Yes	152
hK14	RT-PCR	Favorable	Yes	Yes	153
hK15	RT-PCR	Unfavorable	Yes	Yes	154

to identify cancers of various classes not easily distinguishable using other conventional techniques (163,164).

Recently, this principle was applied to ovarian cancer using affymetrix GeneChip microarrays, Santa Clara, CA (41,165). A 115-gene signature was identified, which could predict poor overall survival and, which maintained independent prognostic value in multivariate analysis (41). Similarly, another study was able to differentiate low-grade from high-grade ovarian cancers based on gene-expression profiles and these profiles were also correlated to outcome (165). It was unclear whether the profile retained independent prognostic value when grade was present in the model. Another study identified gene profiles in clear cell carcinomas that distinguished these tumors from other poor prognosis tumors (33). Overall, these types of analyses are in their infancy, but based on work performed in other cancers and preliminary work in ovarian cancer the future is promising for these approaches. On the other hand, these techniques are much more time-consuming and difficult compared with the measurement of individual biomarkers using immunoassays. Moreover, it is unclear, at this point, whether these gene profiling techniques will necessarily yield superior predictive values compared with a well chosen combination of biomarkers.

#### 4. CONCLUSIONS

Except for CA 125, which can be useful for monitoring relapse in ovarian cancer patients, there are currently no molecular markers appropriate for early detection of ovarian

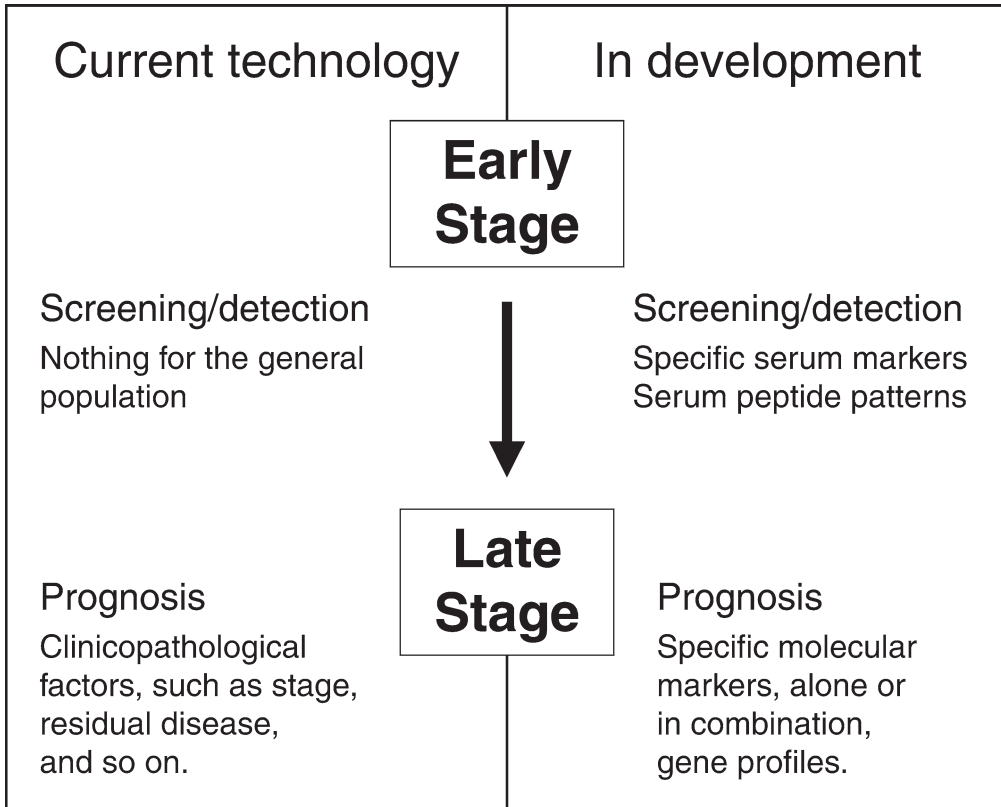

**Fig. 1.** Current and future technology for detection and prognosis of ovarian cancer.

cancer in the general population or for prediction of outcome. The identification of such markers would clearly have a profound impact on ovarian cancer management and on the morbidity of this disease. Many promising avenues are currently being pursued, such as the identification of new targets from large-scale analysis as well as the investigation of known candidates (for example, kallikreins and p27 are particularly promising for diagnosis), alone or in combination. The field of proteomics is also likely to play a more prominent role in the future (*see* Fig. 1). It is hoped that molecular medicine will allow for earlier detection and better insight into treatment outcome, both of which would undoubtedly lead to a concomitant reduction in the number of ovarian cancer deaths.

## REFERENCES

1. Fishman DA, Bozorgi K. The scientific basis of early detection of epithelial ovarian cancer: the National Ovarian Cancer Early Detection Program (NOCEDP). *Cancer Treat Res* 2002; 107: 3–28.
2. Jacobs IJ, Oram DH, Bast RC Jr. Strategies for improving the specificity of screening for ovarian cancer with tumor-associated antigens CA 125, CA 15-3, and TAG 72.3. *Obstet Gynecol* 1992; 80(3 Pt 1): 396–399.
3. Berek JS, Bast RC Jr. Ovarian cancer screening. The use of serial complementary tumor markers to improve sensitivity and specificity for early detection. *Cancer* 1995; 76(Suppl 10): 2092–2096.
4. Bast RC Jr, Feeney M, Lazarus H, Nadler LM, Colvin RB, Knapp RC. Reactivity of a monoclonal antibody with human ovarian carcinoma. *J Clin Invest* 1981; 68: 1331–1337.
5. Bast RC Jr, Klug TL, St John E, et al. A radioimmunoassay using a monoclonal antibody to monitor the course of epithelial ovarian cancer. *N Engl J Med* 1983; 309(15): 883–887.

6. Zurawski VR Jr, Orjaseter H, Andersen A, Jellum E. Elevated serum CA 125 levels prior to diagnosis of ovarian neoplasia: relevance for early detection of ovarian cancer. *Int J Cancer* 1988; 42(5): 677–680.
7. Rubin SC, Hoskins WJ, Hakes TB, et al. Serum CA 125 levels and surgical findings in patients undergoing secondary operations for epithelial ovarian cancer. *Am J Obstet Gynecol* 1989; 160(3): 667–671.
8. Jacobs I, Bast RC Jr. The CA 125 tumour-associated antigen: a review of the literature. *Hum Reprod* 1989; 4(1): 1–12.
9. Jacobs I, Davies AP, Bridges J, et al. Prevalence screening for ovarian cancer in postmenopausal women by CA 125 measurement and ultrasonography. *Bmj* 1993; 306(6884): 1030–1034.
10. Zurawski VR Jr, Sjøvall K, Schoenfeld DA, et al. Prospective evaluation of serum CA 125 levels in a normal population, phase I: the specificities of single and serial determinations in testing for ovarian cancer. *Gynecol Oncol* 1990; 36(3): 299–305.
11. Einhorn N, Sjøvall K, Knapp RC, et al. Prospective evaluation of serum CA 125 levels for early detection of ovarian cancer. *Obstet Gynecol* 1992; 80(1): 14–18.
12. Woolas RP, Oram DH, Jeyarajah AR, Bast RC, Jacobs IJ. Ovarian cancer identified through screening with serum markers but not by pelvic imaging. *Int J Gynecol Cancer* 1999; 9(6): 497–501.
13. Bast RC, Xu FJ, Yu YH, Barnhill S, Zhang Z, Mills GB. CA 125: The past and the future. *Int J Biol Markers* 1998; 13: 179–187.
14. Wang K, Gan L, Jeffery E, et al. Monitoring gene expression profile changes in ovarian carcinomas using cDNA microarray. *Gene* 1999; 229: 101–108.
15. Schummer M, Ng VLV, Baumgarner RE, et al. Comparative hybridization of an array of 21 500 ovarian cDNAs for the discovery of genes overexpressed in ovarian carcinomas. *Gene* 1999; 238: 375–385.
16. Hough CD, Sherman-Baust CA, Pizer ES, et al. Large-Scale Serial Analysis of Gene Expression Reveals Genes Differentially Expressed in Ovarian Cancer. *Cancer Res* 2000; 60: 6281–6287.
17. Hellstrom I, Raycraft J, Hayden-Ledbetter M, et al. The HE4 (WFDC2) Protein Is a Biomarker for Ovarian Carcinoma. *Cancer Res* 2003; 63: 3695–3700.
18. Urban N, McIntosh MW, Andersen M, Karlan BY. Ovarian cancer screening. *Hematol Oncol Clin North Am* 2003; 17(4): 989–1005, ix.
19. Yousef GM, Diamandis EP. The new human tissue kallikrein gene family: structure, function, and association to disease. *Endocr Rev* 2001; 22(2): 184–204.
20. Diamandis EP, Scorilas A, Fracchioli S, et al. Human kallikrein 6 (hK6): a new potential serum biomarker for diagnosis and prognosis of ovarian carcinoma. *J Clin Oncol* 2003; 21(6): 1035–1043.
21. Luo LY, Katsaros D, Scorilas A, et al. The serum concentration of human kallikrein 10 represents a novel biomarker for ovarian cancer diagnosis and prognosis. *Cancer Res* 2003; 63(4): 807–811.
22. Diamandis EP, Okui A, Mitsui S, et al. Human kallikrein 11: a new biomarker of prostate and ovarian carcinoma. *Cancer Res* 2002; 62(1): 295–300.
23. Petricoin EF, Ardekani AM, Hitt BA, et al. Use of proteomic patterns in serum to identify ovarian cancer. *Lancet* 2002; 359(9306): 572–577.
24. Zhang Z, Bast RC Jr, Yu Y, et al. Three biomarkers identified from serum proteomic analysis for the detection of early stage ovarian cancer. *Cancer Res* 2004; 64(16): 5882–5890.
25. Ono K, Tanaka T, Tsunoda T, et al. Identification by cDNA microarray of genes involved in ovarian carcinogenesis. *Cancer Res* 2000; 60(18): 5007–5011.
26. Martoglio AM, Tom BD, Starkey M, Corps AN, Charnock-Jones DS, Smith SK. Changes in tumorigenesis- and angiogenesis-related gene transcript abundance profiles in ovarian cancer detected by tailored high density cDNA arrays. *Mol Med* 2000; 6(9): 750–765.
27. Ismail RS, Baldwin RL, Fang J, et al. Differential gene expression between normal and tumor-derived ovarian epithelial cells. *Cancer Res* 2000; 60(23): 6744–6749.
28. Hough CD, Cho KR, Zonderman AB, Schwartz DR, Morin PJ. Coordinately up-regulated genes in ovarian cancer. *Cancer Res* 2001; 61(10): 3869–3876.
29. Shridhar V, Lee J, Pandita A, et al. Genetic analysis of early- versus late-stage ovarian tumors. *Cancer Res* 2001; 61(15): 5895–5904.
30. Wong KK, Cheng RS, Mok SC. Identification of differentially expressed genes from ovarian cancer cells by MICROMAX cDNA microarray system. *Biotechniques* 2001; 30(3): 670–675.
31. Tonin PN, Hudson TJ, Rodier F, et al. Microarray analysis of gene expression mirrors the biology of an ovarian cancer model. *Oncogene* 2001; 20(45): 6617–6626.
32. Welsh JB, Zarrinkar PP, Sapinoso LM, et al. Analysis of gene expression profiles in normal and neoplastic ovarian tissue samples identifies candidate molecular markers of epithelial ovarian cancer. *Proc Natl Acad Sci USA* 2001; 98(3): 1176–1181.

33. Schwartz DR, Kardia SL, Shedden KA, et al. Gene expression in ovarian cancer reflects both morphology and biological behavior, distinguishing clear cell from other poor-prognosis ovarian carcinomas. *Cancer Res* 2002; 62(16): 4722–4729.
34. Matei D, Graeber TG, Baldwin RL, Karlan BY, Rao J, Chang DD. Gene expression in epithelial ovarian carcinoma. *Oncogene* 2002; 21(41): 6289–6298.
35. Bayani J, Brenton JD, Macgregor PF, et al. Parallel analysis of sporadic primary ovarian carcinomas by spectral karyotyping, comparative genomic hybridization, and expression microarrays. *Cancer Res* 2002; 62(12): 3466–3476.
36. Sawiris GP, Sherman-Baust CA, Becker KG, Cheadle C, Teichberg D, Morin PJ. Development of a highly specialized cDNA array for the study and diagnosis of epithelial ovarian cancer. *Cancer Res* 2002; 62(10): 2923–2928.
37. Shridhar V, Sen A, Chien J, et al. Identification of underexpressed genes in early- and late-stage primary ovarian tumors by suppression subtraction hybridization. *Cancer Res* 2002; 62(1): 262–270.
38. Schaner ME, Ross DT, Ciaravino G, et al. Gene expression patterns in ovarian carcinomas. *Mol Biol Cell* 2003; 14(11): 4376–4386.
39. Shvartsman HS, Lu KH, Lee J, et al. Overexpression of kallikrein 10 in epithelial ovarian carcinomas. *Gynecol Oncol* 2003; 90(1): 44–50.
40. Jazaeri AA, Lu K, Schmandt R, et al. Molecular determinants of tumor differentiation in papillary serous ovarian carcinoma. *Mol Carcinog* 2003; 36(2): 53–59.
41. Spentzos D, Levine DA, Ramoni MF, et al. Gene expression signature with independent prognostic significance in epithelial ovarian cancer. *J Clin Oncol* 2004; 22(23): 4648–4658.
42. Donniger H, Bonome T, Radonovich M, et al. Whole genome expression profiling of advanced stage papillary serous ovarian cancer reveals activated pathways. *Oncogene* 2004; 23(49): 8065–8077.
43. Santin AD, Zhan F, Bellone S, et al. Gene expression profiles in primary ovarian serous papillary tumors and normal ovarian epithelium: Identification of candidate molecular markers for ovarian cancer diagnosis and therapy. *Int J Cancer* 2004; 112(1): 14–25.
44. Adib TR, Henderson S, Perrett C, et al. Predicting biomarkers for ovarian cancer using gene-expression microarrays. *Br J Cancer* 2004; 90(3): 686–692.
45. Lu KH, Patterson AP, Wang L, et al. Selection of potential markers for epithelial ovarian cancer with gene expression arrays and recursive descent partition analysis. *Clin Cancer Res* 2004; 10(10): 3291–3300.
46. Heinzelmann-Schwarz VA, Gardiner-Garden M, Henshall SM, et al. Overexpression of the cell adhesion molecules DDR1, Claudin 3, and Ep-CAM in metaplastic ovarian epithelium and ovarian cancer. *Clin Cancer Res* 2004; 10(13): 4427–4436.
47. Hofseth LJ, Hussain SP, Harris CC. p53: 25 years after its discovery. *Trends Pharmacol Sci* 2004; 25(4): 177–181.
48. Takahashi T, Nau MM, Chiba I, et al. p53: a frequent target for genetic abnormalities in lung cancer. *Science* 1989; 246(4929): 491–494.
49. Nigro JM, Baker SJ, Preisinger AC, et al. Mutations in the p53 gene occur in diverse human tumour types. *Nature* 1989; 342(6250): 705–708.
50. Hollstein M, Sidransky D, Vogelstein B, Harris CC. p53 mutations in human cancers. *Science* 1991; 253(5015): 49–53.
51. Kihana T, Tsuda H, Teshima S, Okada S, Matsuura S, Hirohashi S. High incidence of p53 gene mutation in human ovarian cancer and its association with nuclear accumulation of p53 protein and tumor DNA aneuploidy. *Japan J Cancer Res* 1992; 83(9): 978–984.
52. Okamoto A, Sameshima Y, Yokoyama S, et al. Frequent allelic losses and mutations of the p53 gene in human ovarian cancer. *Cancer Res* 1991; 51(19): 5171–5176.
53. Marks JR, Davidoff AM, Kerns BJ, et al. Overexpression and mutation of p53 in epithelial ovarian cancer. *Cancer Res* 1991; 51(11): 2979–2984.
54. Teneriello MG, Ebina M, Linnoila RI, et al. p53 and Ki-ras gene mutations in epithelial ovarian neoplasms. *Cancer Res* 1993; 53: 3103–3108.
55. Milner BJ, Allan LA, Eccles DM, et al. p53 mutation is a common genetic event in ovarian carcinoma. *Cancer Res* 1993; 53: 2128–2132.
56. van der Zee AG, Hollema H, Suurmeijer AJ, et al. Value of P-glycoprotein, glutathione S-transferase pi, c-erbB-2, and p53 as prognostic factors in ovarian carcinomas. *J Clin Oncol* 1995; 13(1): 70–78.
57. Levesque MA, Katsaros D, Yu H, et al. Mutant p53 protein overexpression is associated with poor outcome in patients with well or moderately differentiated ovarian carcinoma. *Cancer* 1995; 75(6): 1327–1338.

58. Klemi PJ, Pylkkanen L, Kiilholma P, Kurvinen K, Joensuu H. p53 protein detected by immunohistochemistry as a prognostic factor in patients with epithelial ovarian carcinoma. *Cancer* 1995; 76(7): 1201–1208.
59. Diebold J, Baretton G, Felchner M, et al. bcl-2 expression, p53 accumulation, and apoptosis in ovarian carcinomas. *Am J Clin Pathol* 1996; 105(3): 341–349.
60. Buttitta F, Marchetti A, Gadducci A, et al. p53 alterations are predictive of chemoresistance and aggressiveness in ovarian carcinomas: a molecular and immunohistochemical study. *Br J Cancer* 1997; 75(2): 230–235.
61. Geisler JP, Geisler HE, Wiemann MC, Givens SS, Zhou Z, Miller GA. Quantification of p53 in epithelial ovarian cancer. *Gynecol Oncol* 1997; 66(3): 435–438.
62. Dong Y, Walsh MD, McGuckin MA, et al. Reduced expression of retinoblastoma gene product (pRB) and high expression of p53 are associated with poor prognosis in ovarian cancer. *Int J Cancer* 1997; 74(4): 407–415.
63. Anttila MA, Ji H, Juhola MT, Saarikoski SV, Syrjanen KJ. The prognostic significance of p53 expression quantitated by computerized image analysis in epithelial ovarian cancer. *Int J Gynecol Pathol* 1999; 18(1): 42–51.
64. Baekelandt M, Kristensen GB, Nesland JM, Trope CG, Holm R. Clinical significance of apoptosis-related factors p53, Mdm2, and Bcl-2 in advanced ovarian cancer. *J Clin Oncol* 1999; 17: 2061–2068.
65. Sood AK, Sorosky JI, Dolan M, Anderson B, Buller RE. Distant metastases in ovarian cancer: association with p53 mutations. *Clin Cancer Res* 1999; 5(9): 2485–2490.
66. Levesque MA, Katsaros D, Massobrio M, et al. Evidence for a dose-response effect between p53 (but not p21WAF1/Cip1) protein concentrations, survival, and responsiveness in patients with epithelial ovarian cancer treated with platinum-based chemotherapy. *Clin Cancer Res* 2000; 6(8): 3260–3270.
67. Reles A, Wen WH, Schmider A, et al. Correlation of p53 mutations with resistance to platinum-based chemotherapy and shortened survival in ovarian cancer. *Clin Cancer Res* 2001; 7(10): 2984–2997.
68. Schuyer M, van der Burg ME, Henzen-Logmans SC, et al. Reduced expression of BAX is associated with poor prognosis in patients with epithelial ovarian cancer: a multifactorial analysis of TP53, p21, BAX and BCL-2. *Br J Cancer* 2001; 85(9): 1359–1367.
69. Hawes D, Liu PY, Muggia FM, et al. Correlation of p53 immunostaining in primary and residual ovarian cancer at the time of positive second-look laparotomy and its prognostic role: a Southwest Oncology Group ancillary study. *Gynecol Oncol* 2002; 87(1): 17–23.
70. Skirnisdottir I, Seidal T, Gerdin E, Sorbe B. The prognostic importance of p53, bcl-2, and bax in early stage epithelial ovarian carcinoma treated with adjuvant chemotherapy. *Int J Gynecol Cancer* 2002; 12(3): 265–276.
71. Bali A, O'Brien PM, Edwards LS, Sutherland RL, Hacker NF, Henshall SM. Cyclin D1, p53, and p21Waf1/Cip1 expression is predictive of poor clinical outcome in serous epithelial ovarian cancer. *Clin Cancer Res* 2004; 10(15): 5168–5177.
72. Nielsen JS, Jakobsen E, Holund B, Bertelsen K, Jakobsen A. Prognostic significance of p53, Her-2, and EGFR overexpression in borderline and epithelial ovarian cancer. *Int J Gynecol Cancer* 2004; 14(6): 1086–1096.
73. Henriksen R, Strang P, Wilander E, Backstrom T, Tribukait B, Oberg K. p53 expression in epithelial ovarian neoplasms: relationship to clinical and pathological parameters, Ki-67 expression and flow cytometry. *Gynecol Oncol* 1994; 53(3): 301–306.
74. Herod JJ, Eliopoulos AG, Warwick J, Niedobitek G, Young LS, Kerr DJ. The prognostic significance of Bcl-2 and p53 expression in ovarian carcinoma. *Cancer Res* 1996; 56(9): 2178–2184.
75. Werness BA, Freedman AN, Piver MS, Romero-Gutierrez M, Petrow E. Prognostic significance of p53 and p21(waf1/cip1) immunoreactivity in epithelial cancers of the ovary. *Gynecol Oncol* 1999; 75(3): 413–418.
76. Tachibana M, Watanabe J, Matsushima Y, et al. Independence of the prognostic value of tumor suppressor protein expression in ovarian adenocarcinomas: a multivariate analysis of expression of p53, retinoblastoma, and related proteins. *Int J Gynecol Cancer* 2003; 13(5): 598–606.
77. Shahin MS, Hughes JH, Sood AK, Buller RE. The prognostic significance of p53 tumor suppressor gene alterations in ovarian carcinoma. *Cancer* 2000; 89(9): 2006–2017.
78. Skomedal H, Kristensen GB, Abeler VM, Borresen-Dale AL, Trope C, Holm R. TP53 protein accumulation and gene mutation in relation to overexpression of MDM2 protein in ovarian borderline tumours and stage I carcinomas. *J Pathol* 1997; 181(2): 158–165.
79. Hartmann LC, Podratz KC, Keeney GL, et al. Prognostic significance of p53 immunostaining in epithelial ovarian cancer. *J Clin Oncol* 1994; 12: 64–69.

80. Kohler MF, Kerns BJ, Humphrey PA, Marks JR, Bast RC Jr, Berchuck A. Mutation and overexpression of p53 in early-stage epithelial ovarian cancer. *Obstet Gynecol* 1993; 81(5 Pt 1): 643–650.
81. Reles A, Schmider A, Press MF, et al. Immunostaining of p53 protein in ovarian carcinoma: correlation with histopathological data and clinical outcome. *J Cancer Res Clin Oncol* 1996; 122(8): 489–494.
82. Eltabbakh GH, Belinson JL, Kennedy AW, et al. p53 overexpression is not an independent prognostic factor for patients with primary ovarian epithelial cancer. *Cancer* 1997; 80(5): 892–898.
83. Fallows S, Price J, Atkinson RJ, Johnston PG, Hickey I, Russell SE. P53 mutation does not affect prognosis in ovarian epithelial malignancies. *J Pathol* 2001; 194(1): 68–75.
84. Berker B, Dunder I, Ensari A, Cengiz SD. Prognostic value of p53 accumulation in epithelial ovarian carcinomas. *Arch Gynecol Obstet* 2002; 266(4): 205–209.
85. Laframboise S, Chapman W, McLaughlin J, Andrulis IL. p53 mutations in epithelial ovarian cancers: possible role in predicting chemoresistance. *Cancer J* 2000; 6(5): 302–308.
86. Peiro G, Diebold J, Lohrs U. CAS (cellular apoptosis susceptibility) gene expression in ovarian carcinoma: Correlation with 20q13.2 copy number and cyclin D1, p53, and Rb protein expression. *Am J Clin Pathol* 2002; 118(6): 922–929.
87. Kupryjanczyk J, Thor AD, Beauchamp R, et al. p53 gene mutations and protein accumulation in human ovarian cancer. *Proc Natl Acad Sci USA* 1993; 90(11): 4961–4965.
88. Rose SL, Robertson AD, Goodheart MJ, Smith BJ, DeYoung BR, Buller RE. The impact of p53 protein core domain structural alteration on ovarian cancer survival. *Clin Cancer Res* 2003; 9(11): 4139–4144.
89. Plisiecka-Halasa J, Karpinska G, Szymanska T, et al. P21WAF1, P27KIP1, TP53 and C-MYC analysis in 204 ovarian carcinomas treated with platinum-based regimens. *Ann Oncol* 2003; 14(7): 1078–1085.
90. Kupryjanczyk J, Szymanska T, Madry R, et al. Evaluation of clinical significance of TP53, BCL-2, BAX and MEK1 expression in 229 ovarian carcinomas treated with platinum-based regimen. *Br J Cancer* 2003; 88(6): 848–854.
91. Sheridan E, Silcocks P, Smith J, Hancock BW, Goyns MH. P53 mutation in a series of epithelial ovarian cancers from the U.K., and its prognostic significance. *Eur J Cancer* 1994; 30A(11): 1701–1704.
92. Niwa K, Itoh M, Murase T, et al. Alteration of p53 gene in ovarian carcinoma: clinicopathological correlation and prognostic significance. *Br J Cancer* 1994; 70(6): 1191–1197.
93. Allan LA, Campbell MK, Milner BJ, et al. The significance of p53 mutation and over-expression in ovarian prognosis. *Int J Gynecol Cancer* 1996; 196(6): 483–490.
94. Smith-Sorensen B, Kaern J, Holm R, Dorum A, Trope C, Borresen-Dale AL. Therapy effect of either paclitaxel or cyclophosphamide combination treatment in patients with epithelial ovarian cancer and relation to TP53 gene status. *Br J Cancer* 1998; 78: 375–381.
95. Havrilesky L, Darcy M, Hamdan H, et al. Prognostic significance of p53 mutation and p53 overexpression in advanced epithelial ovarian cancer: a Gynecologic Oncology Group Study. *J Clin Oncol* 2003; 21(20): 3814–3825.
96. Wang Y, Helland A, Holm R, et al. TP53 mutations in early-stage ovarian carcinoma, relation to long-term survival. *Br J Cancer* 2004; 90(3): 678–685.
97. Marx D, Meden H, Ziemek T, Lenthe T, Kuhn W, Schauer A. Expression of the p53 tumour suppressor gene as a prognostic marker in platinum-treated patients with ovarian cancer. *Eur J Cancer* 1998; 34(6): 845–850.
98. Sengupta PS, McGown AT, Bajaj V, et al. p53 and related proteins in epithelial ovarian cancer. *Eur J Cancer* 2000; 36(18): 2317–2328.
99. Ferrandina G, Fagotti A, Salerno MG, et al. p53 overexpression is associated with cytoreduction and response to chemotherapy in ovarian cancer. *Br J Cancer* 1999; 81(4): 733–740.
100. Righetti SC, Della Torre G, Pilotti S, et al. A comparative study of p53 gene mutations, protein accumulation, and response to cisplatin-based chemotherapy in advanced ovarian carcinoma. *Cancer Res* 1996; 56(4): 689–693.
101. Nakayama K, Takebayashi Y, Nakayama S, et al. Prognostic value of overexpression of p53 in human ovarian carcinoma patients receiving cisplatin. *Cancer Lett* 2003; 192(2): 227–235.
102. Rohlke P, Milde-Langosch K, Weyland C, Pichlmeier U, Jonat W, Loning T. p53 is a persistent and predictive marker in advanced ovarian carcinomas: multivariate analysis including comparison with Ki67 immunoreactivity. *J Cancer Res Clin Oncol* 1997; 123(9): 496–501.
103. Lavarino C, Pilotti S, Oggionni M, et al. p53 gene status and response to platinum/paclitaxel-based chemotherapy in advanced ovarian carcinoma. *J Clin Oncol* 2000; 18(23): 3936–3945.

104. Murray AW. Recycling the cell cycle: cyclins revisited. *Cell* 2004; 116(2): 221–234.
105. Baekelandt M, Holm R, Trope CG, Nesland JM, Kristensen GB. Lack of independent prognostic significance of p21 and p27 expression in advanced ovarian cancer: an immunohistochemical study. *Clin Cancer Res* 1999; 5(10): 2848–2853.
106. Vassilopoulos I, Korkolopoulou P, Konstantinidou AE, et al. Evaluation of the cyclin-dependent kinase inhibitor p21Cip1 in epithelial ovarian tumors of low malignant potential and adenocarcinomas. *Histol Histopathol* 2003; 18(3): 761–770.
107. Milde-Langosch K, Hagen M, Bamberger AM, Loning T. Expression and prognostic value of the cell-cycle regulatory proteins, Rb, p16MTS1, p21WAF1, p27KIP1, cyclin E, and cyclin D2, in ovarian cancer. *Int J Gynecol Pathol* 2003; 22(2): 168–174.
108. Geisler HE, Geisler JP, Miller GA, et al. p21 and p53 in ovarian carcinoma: their combined staining is more valuable than either alone. *Cancer* 2001; 92(4): 781–786.
109. Newcomb EW, Sosnow M, Demopoulos RI, Zeleniuch-Jacquotte A, Sorich J, Speyer JL. Expression of the cell cycle inhibitor p27KIP1 is a new prognostic marker associated with survival in epithelial ovarian tumors. *Am J Pathol* 1999; 154(1): 119–125.
110. Korkolopoulou P, Vassilopoulos I, Konstantinidou AE, et al. The combined evaluation of p27Kip1 and Ki-67 expression provides independent information on overall survival of ovarian carcinoma patients. *Gynecol Oncol* 2002; 85(3): 404–414.
111. Sui L, Dong Y, Ohno M, et al. Implication of malignancy and prognosis of p27(kip1), Cyclin E, and Cdk2 expression in epithelial ovarian tumors. *Gynecol Oncol* 2001; 83(1): 56–63.
112. Shigemasa K, Shiroyama Y, Sawasaki T, et al. Underexpression of cyclin-dependent kinase inhibitor p27 is associated with poor prognosis in serous ovarian carcinomas. *Int J Oncol* 2001; 18(5): 953–958.
113. Masciullo V, Ferrandina G, Pucci B, et al. p27Kip1 expression is associated with clinical outcome in advanced epithelial ovarian cancer: multivariate analysis. *Clin Cancer Res* 2000; 6(12): 4816–4822.
114. Kusume T, Tsuda H, Kawabata M, et al. The p16-cyclin D1/CDK4-pRb pathway and clinical outcome in epithelial ovarian cancer. *Clin Cancer Res* 1999; 5(12): 4152–4157.
115. Sui L, Dong Y, Ohno M, et al. Inverse expression of Cdk4 and p16 in epithelial ovarian tumors. *Gynecol Oncol* 2000; 79(2): 230–237.
116. Katsaros D, Cho W, Singal R, et al. Methylation of tumor suppressor gene p16 and prognosis of epithelial ovarian cancer. *Gynecol Oncol* 2004; 94(3): 685–692.
117. Kudoh K, Ichikawa Y, Yoshida S, et al. Inactivation of p16/CDKN2 and p15/MTS2 is associated with prognosis and response to chemotherapy in ovarian cancer. *Int J Cancer* 2002; 99(4): 579–582.
118. Dong Y, Walsh MD, McGuckin MA, et al. Increased expression of cyclin-dependent kinase inhibitor 2 (CDKN2A) gene product P16INK4A in ovarian cancer is associated with progression and unfavourable prognosis. *Int J Cancer* 1997; 74(1): 57–63.
119. Rosenberg E, Demopoulos RI, Zeleniuch-Jacquotte A, et al. Expression of cell cycle regulators p57(KIP2), cyclin D1, and cyclin E in epithelial ovarian tumors and survival. *Hum Pathol* 2001; 32(8): 808–813.
120. Sui L, Dong Y, Ohno M, Watanabe Y, Sugimoto K, Tokuda M. Expression of p57kip2 and its clinical relevance in epithelial ovarian tumors. *Anticancer Res* 2002; 22(6A): 3191–3196.
121. Barbieri F, Lorenzi P, Ragni N, et al. Overexpression of cyclin D1 is associated with poor survival in epithelial ovarian cancer. *Oncology* 2004; 66(4): 310–315.
122. Diebold J, Mosinger K, Peiro G, et al. 20q13 and cyclin D1 in ovarian carcinomas. Analysis by fluorescence in situ hybridization. *J Pathol* 2000; 190(5): 564–571.
123. Dhar KK, Branigan K, Parkes J, et al. Expression and subcellular localization of cyclin D1 protein in epithelial ovarian tumour cells. *Br J Cancer* 1999; 81: 1174–1181.
124. Farley J, Smith LM, Darcy KM, et al. Cyclin E expression is a significant predictor of survival in advanced, suboptimally debulked ovarian epithelial cancers: a Gynecologic Oncology Group study. *Cancer Res* 2003; 63(6): 1235–1241.
125. Konstantinidou AE, Korkolopoulou P, Vassilopoulos I, et al. Reduced retinoblastoma gene protein to Ki-67 ratio is an adverse prognostic indicator for ovarian adenocarcinoma patients. *Gynecol Oncol* 2003; 88(3): 369–378.
126. Lohmann CM, League AA, Clark WS, Lawson D, DeRose PB, Cohen C. Bcl-2: bax and bcl-2: Bcl-x ratios by image cytometric quantitation of immunohistochemical expression in ovarian carcinoma: correlation with prognosis. *Cytometry* 2000; 42(1): 61–66.
127. Baekelandt M, Holm R, Nesland JM, Trope CG, Kristensen GB. Expression of apoptosis-related proteins is an independent determinant of patient prognosis in advanced ovarian cancer. *J Clin Oncol* 2000; 18(22): 3775–3781.

128. Mano Y, Kikuchi Y, Yamamoto K, et al. Bcl-2 as a predictor of chemosensitivity and prognosis in primary epithelial ovarian cancer. *Eur J Cancer* 1999; 35(8): 1214–1219.
129. Ferrandina G, Legge F, Martinelli E, et al. Survivin expression in ovarian cancer and its correlation with clinico-pathological, surgical and apoptosis-related parameters. *Br J Cancer* 2005.
130. Cohen C, Lohmann CM, Cotsonis G, Lawson D, Santoianni R. Survivin expression in ovarian carcinoma: correlation with apoptotic markers and prognosis. *Mod Pathol* 2003; 16(6): 574–583.
131. Sui L, Dong Y, Ohno M, Watanabe Y, Sugimoto K, Tokuda M. Survivin expression and its correlation with cell proliferation and prognosis in epithelial ovarian tumors. *Int J Oncol* 2002; 21(2): 315–320.
132. de Bruijn HW, van der Zee AG, Aalders JG. The value of cancer antigen 125 (CA 125) during treatment and follow-up of patients with ovarian cancer. *Curr Opin Obstet Gynecol* 1997; 9(1): 8–13.
133. Yang G, Cai KQ, Thompson-Lanza JA, Bast RC Jr, Liu J. Inhibition of breast and ovarian tumor growth through multiple signaling pathways by using retrovirus-mediated small interfering RNA against Her-2/neu gene expression. *J Biol Chem* 2004; 279(6): 4339–4345.
134. Fajac A, Benard J, Lhomme C, et al. c-erbB2 gene amplification and protein expression in ovarian epithelial tumors: evaluation of their respective prognostic significance by multivariate analysis. *Int J Cancer* 1995; 64(2): 146–151.
135. Tanner B, Kreutz E, Weikel W, et al. Prognostic significance of c-erbB-2 mRNA in ovarian carcinoma. *Gynecol Oncol* 1996; 62(2): 268–277.
136. Ross JS, Yang F, Kallakury BV, Sheehan CE, Ambros RA, Muraca PJ. HER-2/neu oncogene amplification by fluorescence in situ hybridization in epithelial tumors of the ovary. *Am J Clin Pathol* 1999; 111(3): 311–316.
137. Riener EK, Arnold N, Kommos F, Lauinger S, Pfisterer J. The prognostic and predictive value of immunohistochemically detected HER-2/neu overexpression in 361 patients with ovarian cancer: a multicenter study. *Gynecol Oncol* 2004; 95(1): 89–94.
138. Tanabe H, Nishii H, Sakata A, et al. Overexpression of HER-2/neu is not a risk factor in ovarian clear cell adenocarcinoma. *Gynecol Oncol* 2004; 94(3): 735–739.
139. van Dam PA, Vergote IB, Lowe DG, et al. Expression of c-erbB-2, c-myc, and c-ras oncoproteins, insulin-like growth factor receptor I, and epidermal growth factor receptor in ovarian carcinoma. *J Clin Pathol* 1994; 47(10): 914–919.
140. Lukes AS, Kohler MF, Pieper CF, et al. Multivariable analysis of DNA ploidy, p53, and HER-2/neu as prognostic factors in endometrial cancer. *Cancer* 1994; 73(9): 2380–2385.
141. Singleton TP, Perrone T, Oakley G, et al. Activation of c-erbB-2 and prognosis in ovarian carcinoma. Comparison with histologic type, grade, and stage. *Cancer* 1994; 73(5): 1460–1466.
142. Rubin SC, Finstad CL, Wong GY, Almadrones L, Plante M, Lloyd KO. Prognostic significance of HER-2/neu expression in advanced epithelial ovarian cancer: a multivariate analysis. *Am J Obstet Gynecol* 1993; 168(1 Pt 1): 162–169.
143. Camilleri-Broet S, Hardy-Bessard AC, Le Tourneau A, et al. HER-2 overexpression is an independent marker of poor prognosis of advanced primary ovarian carcinoma: a multicenter study of the GINECO group. *Ann Oncol* 2004; 15(1): 104–112.
144. Felip E, Del Campo JM, Rubio D, Vidal MT, Colomer R, Bermejo B. Overexpression of c-erbB-2 in epithelial ovarian cancer. Prognostic value and relationship with response to chemotherapy. *Cancer* 1995; 75(8): 2147–2152.
145. Meden H, Marx D, Raab T, Kron M, Schauer A, Kuhn W. EGF-R and overexpression of the oncogene c-erbB-2 in ovarian cancer: immunohistochemical findings and prognostic value. *J Obstet Gynaecol* 1995; 21(2): 167–178.
146. Pegram MD, Finn RS, Arzoo K, Beryt M, Pietras RJ, Slamon DJ. The effect of HER-2/neu overexpression on chemotherapeutic drug sensitivity in human breast and ovarian cancer cells. *Oncogene* 1997; 15(5): 537–547.
147. Agus DB, Bunn PA Jr, Franklin W, Garcia M, Ozols RF. HER-2/neu as a therapeutic target in non-small cell lung cancer, prostate cancer, and ovarian cancer. *Semin Oncol* 2000; 27(6 Suppl 11): 53–63; discussion 92–100.
148. Luo LY, Katsaros D, Scorilas A, et al. Prognostic value of human kallikrein 10 expression in epithelial ovarian carcinoma. *Clin Cancer Res* 2001; 7(8): 2372–2379.
149. Diamandis EP, Borgono CA, Scorilas A, Harbeck N, Dorn J, Schmitt M. Human kallikrein 11: an indicator of favorable prognosis in ovarian cancer patients. *Clin Biochem* 2004; 37(9): 823–829.
150. Shigemasa K, Gu L, Tanimoto H, O'Brien TJ, Ohama K. Human kallikrein gene 11 (KLK11) mRNA overexpression is associated with poor prognosis in patients with epithelial ovarian cancer. *Clin Cancer Res* 2004; 10(8): 2766–2770.



151. Borgono CA, Fracchioli S, Yousef GM, et al. Favorable prognostic value of tissue human kallikrein 11 (hK11) in patients with ovarian carcinoma. *Int J Cancer* 2003; 106(4): 605–610.
152. Scorilas A, Borgono CA, Harbeck N, et al. Human kallikrein 13 protein in ovarian cancer cytosols: a new favorable prognostic marker. *J Clin Oncol* 2004; 22(4): 678–685.
153. Yousef GM, Fracchioli S, Scorilas A, et al. Steroid hormone regulation and prognostic value of the human kallikrein gene 14 in ovarian cancer. *Am J Clin Pathol* 2003; 119(3): 346–355.
154. Yousef GM, Scorilas A, Katsaros D, et al. Prognostic value of the human kallikrein gene 15 expression in ovarian cancer. *J Clin Oncol* 2003; 21(16): 3119–3126.
155. Xi Z, Kaern J, Davidson B, et al. Kallikrein 4 is associated with paclitaxel resistance in ovarian cancer. *Gynecol Oncol* 2004; 94(1): 80–85.
156. Obiezu CV, Scorilas A, Katsaros D, et al. Higher human kallikrein gene 4 (KLK4) expression indicates poor prognosis of ovarian cancer patients. *Clin Cancer Res* 2001; 7(8): 2380–2386.
157. Diamandis EP, Borgono CA, Scorilas A, et al. Immunofluorometric quantification of human kallikrein 5 expression in ovarian cancer cytosols and its association with unfavorable patient prognosis. *Tumour Biol* 2003; 24(6): 299–309.
158. Kim H, Scorilas A, Katsaros D, et al. Human kallikrein gene 5 (KLK5) expression is an indicator of poor prognosis in ovarian cancer. *Br J Cancer* 2001; 84(5): 643–650.
159. Hoffman BR, Katsaros D, Scorilas A, et al. Immunofluorometric quantitation and histochemical localisation of kallikrein 6 protein in ovarian cancer tissue: a new independent unfavourable prognostic biomarker. *Br J Cancer* 2002; 87(7): 763–771.
160. Shigemasa K, Tian X, Gu L, et al. Human kallikrein 8 (hK8/TADG-14) expression is associated with an early clinical stage and favorable prognosis in ovarian cancer. *Oncol Rep* 2004; 11(6): 1153–1159.
161. Magklara A, Scorilas A, Katsaros D, et al. The human KLK8 (neuropsin/ovasin) gene: identification of two novel splice variants and its prognostic value in ovarian cancer. *Clin Cancer Res* 2001; 7(4): 806–811.
162. Yousef GM, Kyriakopoulou LG, Scorilas A, et al. Quantitative expression of the human kallikrein gene 9 (KLK9) in ovarian cancer: a new independent and favorable prognostic marker. *Cancer Res* 2001; 61(21): 7811–7818.
163. Golub TR, Slonim DK, Tamayo P, et al. Molecular classification of cancer: class discovery and class prediction by gene expression monitoring. *Science* 1999; 286(5439): 531–537.
164. Ramaswamy S, Tamayo P, Rifkin R, et al. Multiclass cancer diagnosis using tumor gene expression signatures. *Proc Natl Acad Sci USA* 2001; 98(26): 15,149–15,154.
165. Meinhold-Heerlein I, Bauerschlag D, Hilpert F, et al. Molecular and prognostic distinction between serous ovarian carcinomas of varying grade and malignant potential. *Oncogene* 2004; 24(6): 1053–1065.

# III

---

## ENDOMETRIAL CANCER

---

# 4

---

## Introduction to Endometrial Cancer

*Overview of Endometrial Adenocarcinoma, Classification of Preinvasive Disease, the Biology and Therapy of Advanced Disease, and Conclusions and Future Directions*

---

*Richard J. Zaino, MD*

### CONTENTS

AN OVERVIEW OF ENDOMETRIAL ADENOCARCINOMA  
THE CLASSIFICATION OF PREINVASIVE DISEASE  
THE BIOLOGY AND THERAPY OF ADVANCED ENDOMETRIAL  
ADENOCARCINOMA  
CONCLUSIONS AND FUTURE DIRECTIONS  
REFERENCES

---

### 1. AN OVERVIEW OF ENDOMETRIAL ADENOCARCINOMA

Endometrial adenocarcinoma is the most common invasive malignant neoplasm of the female genital tract, with an estimated 40,000 diagnosed cases and 6600 deaths in 2002 in the United States (1). Fortunately, surgery alone provides effective therapy for about 80% of these women, but very few of those with advanced or metastatic disease are cured by radiation, hormonal or chemotherapy. Significant future improvements in survival most likely will result from a better understanding of the pathways involved in carcinogenesis and metastasis, with concomitant clarification of the specific precursor lesions and identification of molecular targets for preinvasive and advanced disease.

#### *1.1. The Epidemiology of Endometrial Adenocarcinoma*

Endometrial adenocarcinoma rarely occurs before the age of 40 (2,3), but the incidence rises dramatically between the ages of 45 and 65, following which it plateaus (4). Estrogens stimulate the proliferation of the normal endometrial glands and stroma, so it should not be surprising to find that most of the risk factors for endometrial hyperplasia and carcinoma reflect either exogenous or endogenous states of hyperestrogenism. Risk factors for endometrial carcinoma include long-term unopposed estrogen therapy,

From: *Current Clinical Oncology: Molecular Pathology of Gynecologic Cancer*  
Edited by: A. Giordano, A. Bovicelli, and R. Kurman © Humana Press Inc., Totowa, NJ

tamoxifen therapy, polycystic ovarian syndrome, estrogen-producing tumors, a history of nulliparity or infertility, irregular menstrual cycles, early age at menarche, late age at menopause, obesity, diabetes mellitus, and hypertension (4–9).

Case-control studies have shown a relative risk of about 4 (range of 2–10) for women who have used long-term unopposed estrogen. In general, the tumors arising in users of estrogen are of endometrioid cell type, of low stage, and low grade, and these women are more likely to be younger, white, and nonobese. The endometrial carcinoma survival rate is higher for the women who have a history of estrogen use, which in part may be explained by the prognostic factors already delineated. However, after adjustment for the common prognostic factors, the probability of survival remains significantly less for the estrogen nonusers. A detection bias has been suggested as a possible explanation, because women being treated with estrogens are monitored more closely than the general population. In addition, it is possible that some endometrial carcinomas only achieve clinical detection when stimulated by estrogen. This hypothesis is supported by the observation of Horwitz et al. (10) of a fourfold increase in the rate of endometrial cancer in an autopsy-based study compared with the population-based incidence.

Carcinomas which occur in women under the age of 40 years are almost invariably associated with endogenous hyperestrinism, including obesity, anovulation, nulliparity, and polycystic ovary syndrome.

Tamoxifen, a nonsteroidal selective estrogen receptor modulator, has estrogen agonistic and antagonistic activities that are site specific. It has been extensively used in the last decade as adjuvant therapy following surgical treatment of breast cancer, for the treatment of metastatic breast carcinoma, and for prophylaxis against the breast carcinoma in high-risk populations. Fornander et al. (11) in a study of tamoxifen use as adjuvant therapy in more than 1800 menopausal women with breast carcinoma observed a sixfold increase in the relative risk of endometrial carcinoma. In a similar study, Fisher et al. (12) found a relative risk of 15 in the randomized tamoxifen treated group compared with the placebo group from the National Surgical Adjuvant Breast and Bowel Project. Although Magriples et al. (13) found the tamoxifen associated cancers to be of more aggressive cell type and have worse prognosis than those occurring in the general population, this observation has not been confirmed (14).

Obesity, diabetes mellitus, late menopause (i.e., after age 55), and nulliparity are each associated with about a twofold increase risk of developing endometrial adenocarcinoma. Although, often cited as a risk factor, the significance of hypertension is lost when adjusted for obesity.

One risk factor unassociated with estrogen is hereditary, nonpolyposis colon carcinoma, with affected individuals having a 50–40-fold relative risk of developing endometrial carcinoma. The lifetime absolute probability approaches 50% for those who carry the germ-line mutation (15). It is this population for whom it is reasonable to consider annual screening or prophylactic hysterectomy.

### ***1.2. Two Types of Endometrial Adenocarcinoma***

About 20 years back, Bokhman (16) suggested that there were two pathogenetic forms of endometrial adenocarcinoma, the first arising in women with obesity, hyperlipidemia, and signs of hyperestrogenism, such as anovulatory bleeding, infertility, late onset of menopause, hyperplasia of the ovarian stroma, and endometrial hyperplasia;

the second arising in women without such signs. The first, more common type, was found to be more often well differentiated, only superficially invasive, sensitive to progestin therapy, and with a favorable prognosis. In contrast, the second type was more often poorly differentiated, deeply invasive, more often associated with nodal metastasis, less often sensitive to progestins, and with a less favorable prognosis (16). This division has been supported and refined by subsequent investigators (17,18). Pathologists recognize that endometrial adenocarcinoma may have any of the variety of histologically defined cell types, each of which falls into one of the two pathogenetic types. Most endometrioid adenocarcinomas, with or without squamous differentiation, mucinous adenocarcinomas, and villoglandular adenocarcinomas are of the first type. Whereas uterine papillary serous carcinomas (UPSC), clear cell carcinomas, and some poorly differentiated endometrioid adenocarcinomas fall into the second group. Although all of the first types display similar biological behavior, among the second type, the patterns of spread and preinvasive disease differ according to the cell type.

### ***1.3. The Histological Classification of Endometrial Adenocarcinoma***

The current classification of endometrial adenocarcinomas by the International Society of Gynecological Pathologists and the World Health Organization (WHO) (19) divides neoplasms according to histologically defined features that describe the appearances of individual neoplastic cells. Pathologists recognize that the cell types in themselves do not imply any particular biological behavior, but these features probably represent reasonably good surrogates for molecular changes that have yet to be defined.

*Endometrioid adenocarcinoma* is the prototypical endometrial adenocarcinoma and retains the basic architectural arrangement of endometrial glands of varying complexity with a lining of stratified, columnar, epithelial cells (Fig. 1). Decreasing differentiation is characterized by an increasing proportion of tumor made up of solid masses of epithelial cells. Intraglandular papillae formed exclusively of neoplastic cells without a supporting stroma may be present, and a cribriform growth is common in well-differentiated tumors, which are confined to the endometrium. The glands of endometrioid adenocarcinoma are formed of tall columnar cells that share a common apical border, resulting in a smoothly delineated, round or oval luminal contour. With decreasing differentiation, there is a preponderance of solid growth rather than gland formation. About 60% of endometrioid adenocarcinomas contain inactivating mutations in the tumor suppressor gene *PTEN*.

*Secretory adenocarcinoma* is an uncommon variant of typical endometrioid adenocarcinoma in which well-formed tubular glands are lined by a columnar epithelium in which there is prominent subnuclear, and sometimes supranuclear, vacuolization. This change sometimes reflects a response to progestin exposure either from ovulation or rarely exogenous progestin therapy.

*Villoglandular adenocarcinoma* is another subtype of endometrioid adenocarcinoma and is characterized by papillae formed of tall, thin, occasionally branching fibrovascular cores, covered by columnar cells with a straight apical border and generally low-grade nuclei (Fig. 2). The arrangement of neoplastic cells on the connective tissue cores is analogous to the arrangement of the cells that line glands in a typical endometrial adenocarcinoma, with the formation of a smooth apical border. About half of villoglandular carcinomas are admixed with endometrioid adenocarcinomas.

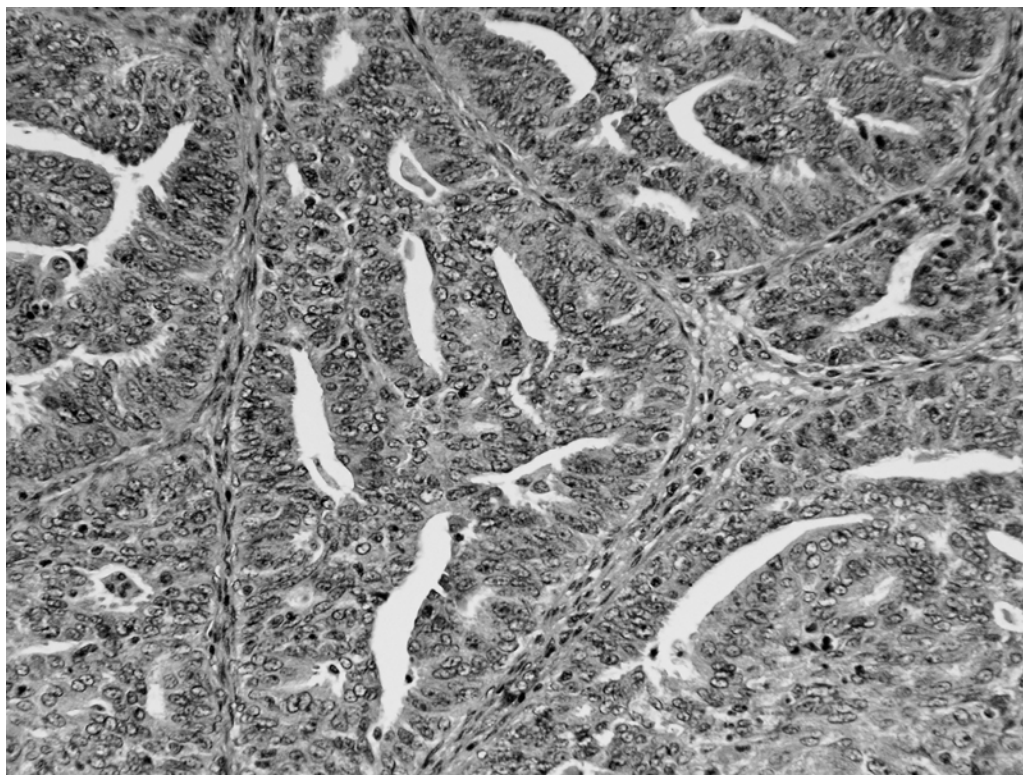

**Fig. 1.** Endometrioid adenocarcinoma. Neoplastic tubules or glands are lined by tall columnar epithelial cells that share luminal borders. A cribriform or sieve-like arrangement results from the mixture of multiple glands and lumina without intervening stroma.

Adenocarcinomas with foci of squamous differentiation represent about 20% of endometrial cancers (20–23) (Fig. 3). Usually, the squamous differentiation in an endometrial adenocarcinoma is easy to recognize. Sheets of keratin, isolated cell keratinization, or intercellular bridges are often conspicuous. However, in order to distinguish foci of squamous differentiation from the poorly differentiated solid portions of adenocarcinoma, more subtle features should also be sought, including the presence of distinct cell membranes accompanied by more abundant eosinophilic cytoplasm than other cells in the same tumor (19). The squamous component may appear histologically benign, atypical, or overtly malignant.

*Mucinous adenocarcinoma* may be entirely tubular or cribriform, but more often has a papillary architecture. The covering epithelium is made up of multiple layers of columnar cells, with intracytoplasmic mucin variably filling the apical portion of the cells, resembling the arrangement of endocervical type epithelium (Fig. 4). Occasionally, an endometrial adenocarcinoma might contain cells with the distended, discrete, apical vacuole characteristic of a goblet cell. Usually intracytoplasmic mucin is easy to identify as finely granular compared with diffuse pale basophilia, but in questionable cases, the reaction with mucicarmine or alcian blue stain within neoplastic cells can confirm its presence. The stroma may not be clearly of endometrial type, and often contains spindled cells, thin walled blood vessels, and variably dense



**Fig. 2.** Villoglandular adenocarcinoma. The neoplastic cells closely resemble those of endometrioid adenocarcinoma, but the architectural arrangement is villous rather than glandular.

infiltrates of acute inflammatory cells. It is a relatively rare form of endometrial adenocarcinoma (24–26), with a mean age at diagnosis of about 60 years, and with a generally good prognosis.

*Serous adenocarcinoma* or UPSC of the endometrium is histologically similar to its counterpart in the ovary. It is characterized by branching complex papillae, formed of fibrovascular cores, covered by one or more layers of cuboidal cells with high-grade nuclei and a scalloped apical border (Fig. 5). Usually, the fibrovascular cores are blunt and hyalinized, but occasionally they are thin and delicate. Detached tufts of epithelial cells and psammoma bodies are often present. Whereas papillae typically forms the superficial portion of the tumor, irregularly dilated or gaping glands made up of cells with similar cytological atypia, commonly constitute the deeper aspect of these neoplasms. The neoplastic cell cytoplasm is often eosinophilic and finely granular. Large nucleoli and aberrant mitotic figures are common.

Serous carcinomas sometimes arise within endometrial polyps or in a background of atrophy. Most UPSC have inactivating mutations that result in histological overexpression of p53. The overall 5-year survival rate has varied from less than 40% to about 60% (27–37). The patients are often of advanced age, and most have either clinically advanced disease or unsuspected metastases discovered at surgery (32,38–43).

*Clear cell adenocarcinoma* of the endometrium is generally recognized by the distinctive, clear cytoplasm of neoplastic cells growing in any combination of solid, glandular,

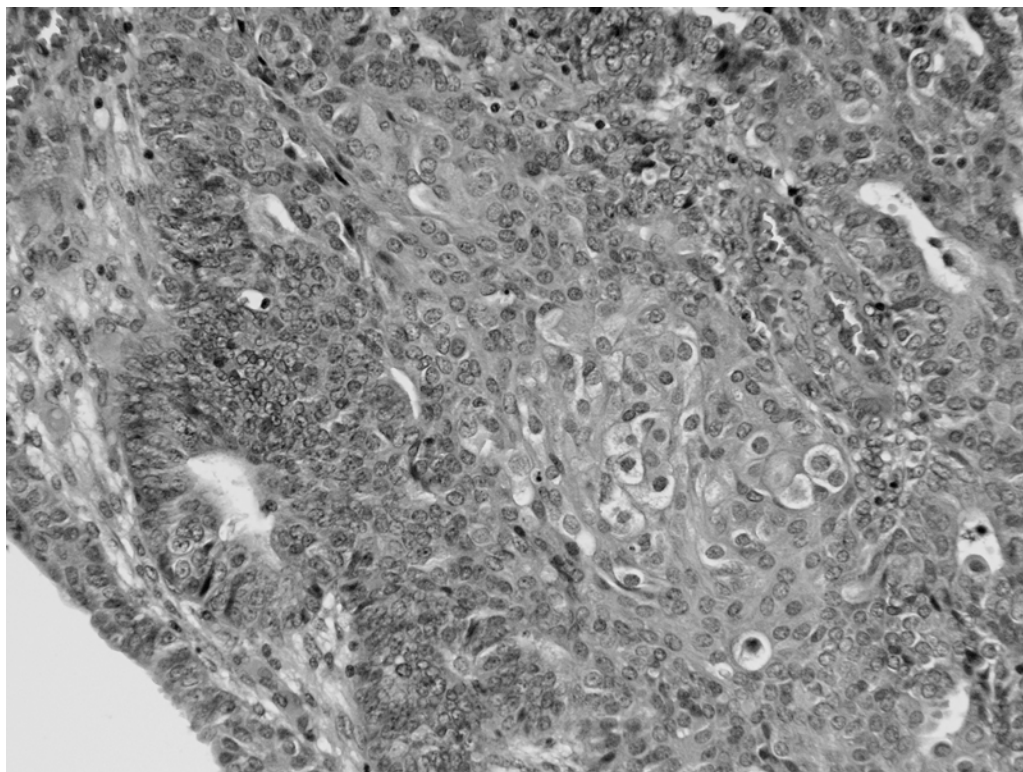

**Fig. 3.** Adenocarcinoma with squamous differentiation. Solid nests of neoplastic cells with abundant eosinophilic cytoplasm and distinct borders (center) provide evidence of squamous differentiation. Keratin production is variable.

tubulocystic, or papillary configurations (Fig. 6). The solid pattern consists of masses of large neoplastic cells of polygonal shape, with clear to faintly eosinophilic cytoplasm, and distinct cell membranes. The glandular pattern is reminiscent of the tubular glands of endometrioid adenocarcinoma, whereas the tubulocystic pattern is formed of dilated spherical appearing glands. The papillary pattern is architecturally identical to that of serous carcinoma, with generally short, branching fibrovascular cores, often hyalinized, covered by neoplastic cells. The last three patterns often have lining cells with a hobnail appearance, resulting from the scalloped apex of individual neoplastic cells, which project along the surface. Many tumors contain scattered densely eosinophilic intracytoplasmic inclusions, which are periodic acid-schiff reaction (PAS) positive, and resistant to diastase digestion. About 4% of endometrial adenocarcinomas are of clear cell type (20,44–48). The mean age at diagnosis is about 68 years, which is similar to that of serous adenocarcinoma and about 6 years older than that of typical endometrial adenocarcinoma. It is a biologically aggressive neoplasm, with a 5-year survival rate varying from only about 20–65% (46–49).

## 2. THE CLASSIFICATION OF PREINVASIVE DISEASE

### 2.1. Introduction

The existence of a precursor to typical invasive endometrial adenocarcinoma has been proposed for more than 100 years (50), but its histological characteristics and classification



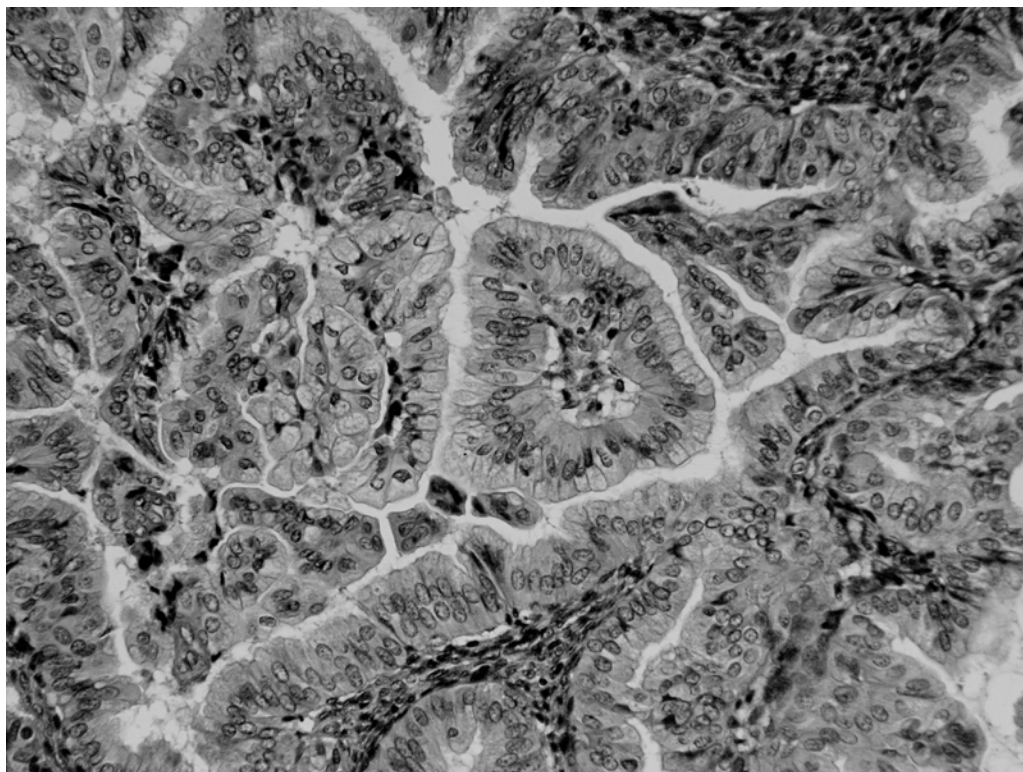

**Fig. 4.** Mucinous adenocarcinoma. Occasional adenocarcinomas are largely made up of cells with large apical cytoplasmic vacuoles containing mucin. The architecture is frequently papillary.

have been disputed throughout its history. These debates reflect at least four features related to the endometrium. First, it is a highly dynamic tissue the histological appearance of which changes markedly throughout reproductive life and the menstrual cycle each month. Second, the precursor lesion cannot be examined without at least partial removal. Third, the lesions examined may represent either a physiological response to hyperestrogenism (hyperplasia) or a selective clonal proliferation (neoplasia). Fourth, the endometrial glands exist as multiple units within a cellular stroma. Unlike the cervix, a basement membrane does not delineate in-situ from invasive lesions. Consequently, even today, the earliest features of invasion have yet to be defined.

In recent years, it has also become evident that there are probably two major categories of endometrial adenocarcinoma with differing etiology, pathogenesis, biological behavior, and response to therapy. Their precursor lesions also appear to be histologically and biologically distinct, and they will be considered as separate entities—*endometrial hyperplasia* and *endometrial intraepithelial carcinoma* (51).

## ***2.2. Endometrial Hyperplasia—Evolving Definitions, Current Classification, and Diagnostic Reproducibility***

The lexicon for endometrial cancer precursors is large and confusing, reflecting repeated reclassifications of these lesions based on relatively scant, and usually retrospectively collected data (52–59). Not surprisingly, the same terms sometimes have been

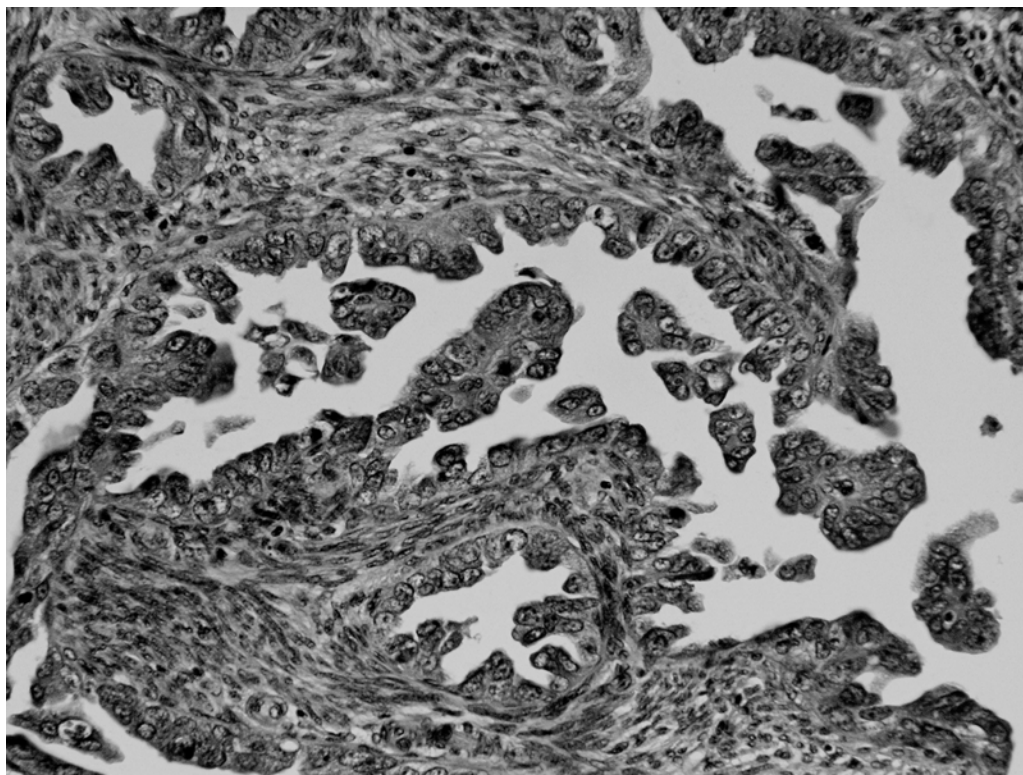

**Fig. 5.** Serous carcinoma. Although some serous carcinomas have a distinctive papillary configuration with highly atypical neoplastic cells covering fibrovascular cores, much of the tumor might be made up of glands with either a scalloped apical cell border or intraglandular papillae.

applied to lesions of differing histological appearance in different classification schemes. For example, although some have suggested that all hyperplasias by definition are at least mildly atypical, others have confined *atypical hyperplasia* to only the lesions, which most closely approximate carcinoma histologically. However, the upper end of this spectrum has also been designated *marked adenomatous hyperplasia* or *carcinoma in situ* in other classification schemes. Much confusion has also resulted from the difficulty in determining the natural history and biological behavior of these lesions because they are usually sampled only following the onset of symptoms, and they are often found to be highly heterogeneous when the endometrium is examined thoroughly in the hysterectomy specimen.

The current classification, adopted by both the International Society of Gynecological Pathologists and the WHO, was proposed by Kurman, Kaminski, and Norris in 1985 (57). They divided endometrial hyperplasia into four groups according to the presence or absence of cytological atypia, and the degree of architectural complexity and crowding, as follows: simple hyperplasia, complex hyperplasia, simple atypical hyperplasia, and complex atypical hyperplasia. *Simple hyperplasia* is defined as an increase in the number of endometrial glands, which may be dilated with little crowding or have an irregular outline and exhibit crowding (Fig. 7). *Complex hyperplasia* is characterized by glands with irregular outlines, marked structural complexity, and back-to-back crowding (Fig. 8). *Atypical hyperplasia* is used to designate a proliferation of glands exhibiting



**Fig. 6.** Clear cell adenocarcinoma. This form of adenocarcinoma is characterized by cells with either abundant optically clear cytoplasm or a hobnail arrangement of cells growing as cystically dilated glands, tubules, papillae, or solid masses.

cytological atypia, recognized as nuclear enlargement, the presence of nucleoli, or a change from an elongated to more ovoid or round nucleus (Figs. 9 and 10). The chromatin might be either evenly or irregularly dispersed. This classification was justified on the basis of differing outcomes for the various groups, with progression to carcinoma in 1% of patients with simple hyperplasia, 3% of those with complex hyperplasia, 8% of those with simple atypical hyperplasia, and 29% of those with complex atypical hyperplasia. In that retrospective study, about two-thirds of the women received some surgical or hormonal modulation during the interval between initial diagnosis and hysterectomy, which varied from 1 to 27 years (mean of 15 years). As noted by Kendall et al. (60), the definitions of architectural complexity and nuclear atypia potentially rest on a multitude of criteria, and some but not all criteria may be fully developed in any given case.

Concern about the reliability of the pathologists to apply multiple criteria to distinguish among these forms of hyperplasia led to three articles and several abstracts assessing the reproducibility of the diagnoses. Skov et al. (61) compared the reproducibility of the WHO classifications of 1975 and 1994 of endometrial hyperplasia, circulating slides of 128 cases of hyperplasia to 6 experienced gynecological pathologists in Denmark. They found intraobserver reproducibility to be moderate for both systems, and interobserver reproducibility to be slight to moderate for various subtypes. Kendall et al. (60) examined the reproducibility of the diagnosis of endometrial hyperplasia and well-differentiated adenocarcinoma among five pathologists of varying experience at

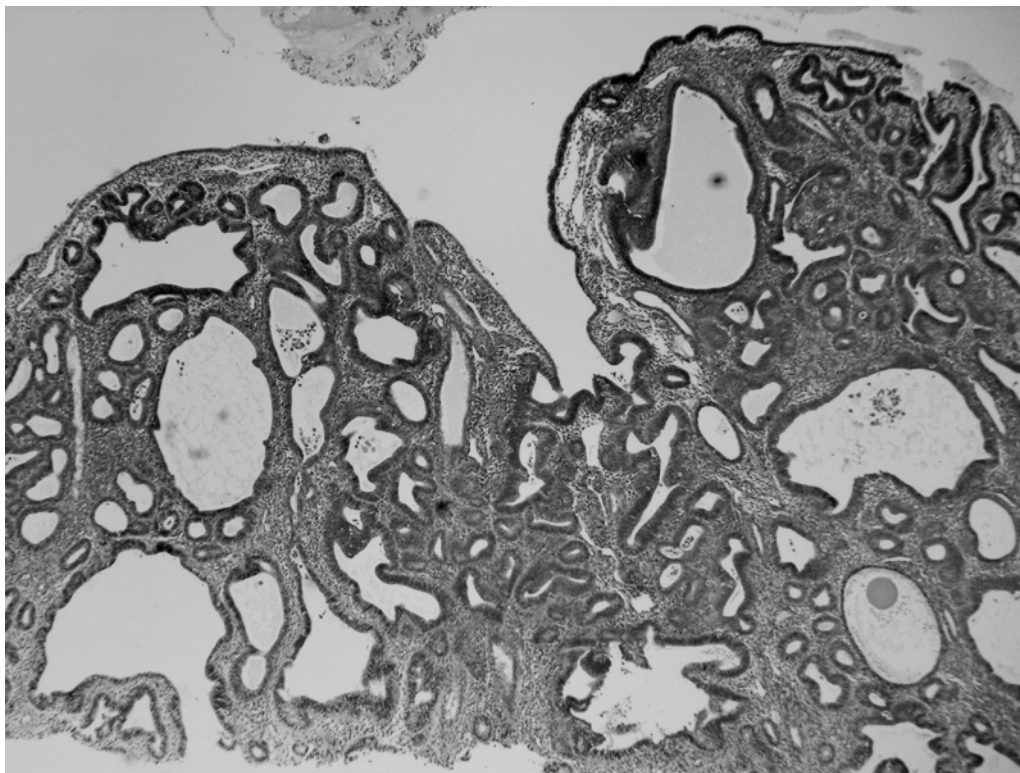

**Fig. 7.** Simple hyperplasia. Hyperplasia is generally characterized by a preferential proliferation of endometrial glands, resulting in an increase in the ratio of glands to stroma. The glands may be cystically dilated, or have branching or bifurcation. In simple hyperplasia, easily identifiable stroma separates the abnormal appearing glands.

Johns Hopkins Hospital. Intraobserver agreement was substantial. Interobserver agreement was highly variable, with almost perfect agreement for the diagnosis of proliferative endometrium or well-differentiated adenocarcinoma, substantial reproducibility for simple hyperplasia, moderate reproducibility for complex nonatypical and atypical hyperplasia, but only slight for simple atypical hyperplasia. Bergeron et al. (62) conducted a European multicenter study of the reproducibility of the WHO classification of endometrial hyperplasia. The intraobserver agreement was moderate, and the interobserver reproducibility was fair to moderate. They suggested condensing atypical hyperplasia and well-differentiated adenocarcinoma into a category of *endometrioid neoplasia*, and designating nonatypical, simple, and complex hyperplasia as *hyperplasia*. The gynecological oncology group recently completed a study of the reproducibility of the community-based diagnosis of atypical hyperplasia in about 300 women, the results of which have been reported in abstract form. A panel of the three gynecological pathologists each reviewed the slides, blinded to the interpretations of the other panelists. A panel diagnosis was defined as agreement of assignment of a case to one of the five categories by two of three or all three-panel pathologists. The panel agreed with the diagnosis of atypical hyperplasia in only 39% of cases, interpreting about one quarter of cases as a less significant process and about one quarter of cases as adenocarcinoma. Interobserver reproducibility among the panel pathologists was the lowest for the

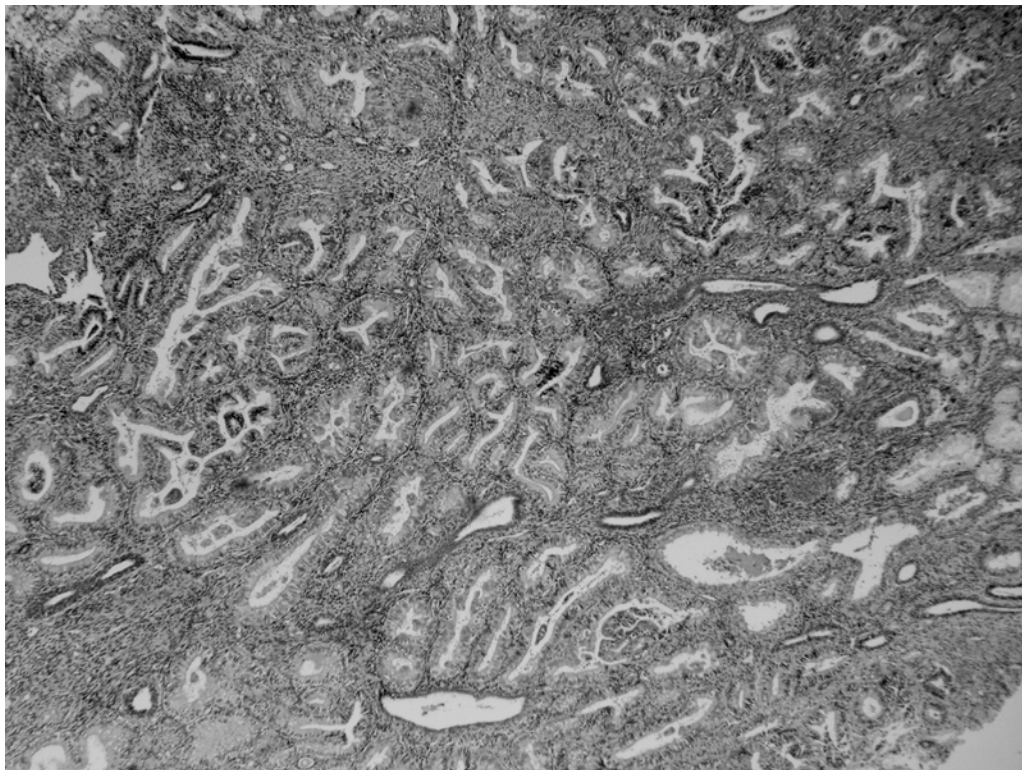

**Fig. 8.** Complex hyperplasia. In addition to higher glandular complexity, little stroma separates the glands from one another.

diagnosis of atypical hyperplasia, with a  $\kappa$  value of about 0.27. Hysterectomy subsequently performed within 12 weeks of initial diagnosis revealed the presence of coexisting adenocarcinoma in the uterus in about 43% of cases. These disturbing results raise serious questions about the ability of pathologists to recognize and distinguish endometrial precancers from carcinoma in biopsies or curettings.

Factors contributing to low reproducibility include:

1. The fragmentary nature of biopsies or curettings;
2. The presence of borderline lesions;
3. Uncertainty about the significance of focal hyperplasia;
4. Artifacts relating to poor fixation, cryotomy, and staining;
5. The inadequacy of published descriptions and understanding of terms used to define architectural or cytological atypia; and
6. The difficulty associated with the translation of verbal descriptions into light microscopic interobserver reproducibility for images.

The difficulty in identifying distinctive subjective histological characteristics associated with differing biological behavior encouraged investigations using morphometric analysis. Colgan et al. (63), and Baak et al. (64–67) investigated features of gland cell nuclei. Colgan et al. (63) found that a linear discriminant function selected the mean and standard deviation of the maximal nuclear diameter as the most useful predictor of eventual progression of atypical endometrial hyperplasia to adenocarcinoma. However,

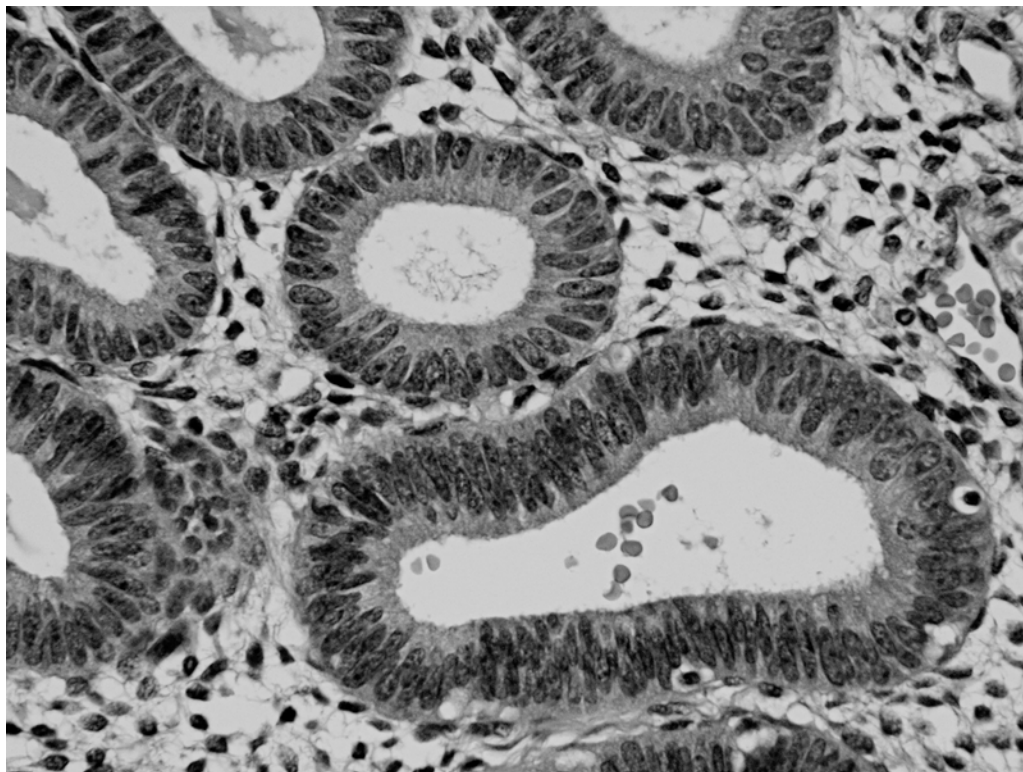

**Fig. 9.** Atypical hyperplasia. Hyperplasia is also divided according to the absence or presence of cytological atypia. This atypia is usually defined as the presence of nuclear enlargement, abnormal chromatin distribution, and especially the presence of nucleoli. Because fixation and staining of specimens are variable, comparison of features with adjacent nonhyperplastic gland nuclei may be helpful.

a significant number of false-negatives and false-positives resulted from this classification rule, particularly when the study set included other types of endometrial proliferations (64,68,69). Norris et al. (70) examined DNA light absorbance and added epithelial cellularity to the features examined. Although DNA content was not helpful, the addition of epithelial cellularity to the nuclear features improved prognostication.

Baak et al. (66,69) have performed exhaustive studies, noting that a combination of architectural and nuclear features improved the ability to discriminate lesions, which progressed from those that failed to progress to carcinoma. Using a relatively comprehensive list of 22 architectural and nuclear features, linear stepwise regression, and discriminant analyses, they concluded that volume percent stroma, standard deviation of the shortest nuclear axis, and the outer surface density of the glands are the most important discriminant factors (D-score). In a follow-up study (71), using another set of 55 biopsies and curettings with follow-up hysterectomy averaging 3 months after initial sampling, this morphometric assessment was both relatively sensitive and specific.

During the last 10 years, Mutter, Baak, and colleagues (72) have attempted to determine whether the morphometric data distinguish clonal lesions from those that are polyclonal. They initially determined that endometrial hyperplasia included both polyclonal and clonal proliferations using a polymerase chain reaction assay for nonrandom X chromosome inactivation (73). Subsequent studies demonstrated that the clonal lesions were highly correlated with a morphometrically identifiable subset of lesions



**Fig. 10.** Typical hyperplasia. In this hyperplasia, the nuclei retain a stratified arrangement, with dense chromatin and inconspicuous or absent nucleoli.

with a low D-score, and that these could be recognized subjectively by pathologists by having a volume percent stroma of less than 55% (74). They suggest classifying such lesions as endometrial intraepithelial neoplasia (EIN) (75) in contrast to those polyclonal lesions with different morphology and morphometry, which they would consider to represent endometrial hyperplasia. This subject is discussed in more detail in Chapter 6. To date, the reproducibility of this distinction made subjectively by pathologists has not been formally evaluated.

It is evident that in spite of efforts to provide rigorous histological criteria that reproducibly would distinguish various categories of endometrial cancer precursors, such criteria still elude pathologists. If a morphological classification scheme is to fulfill these criteria, it almost certainly will have to be based on correlations with clonality, morphometry, gene expression or protein expression profiles as well as outcome data. Further, it is evident that the molecular alterations and pathways involved in endometrial carcinogenesis need to be correlated with histological features.

### ***2.3. Endometrial Intraepithelial Carcinoma***

During the last 10 years, endometrial intraepithelial carcinoma (EIC) has been identified and recognized as a histologically distinctive lesion that is specifically associated with serous carcinoma of the endometrium (76–80). Serous carcinomas represent one of the second types of endometrial carcinomas. In contrast with endometrioid adenocarcinoma, these mostly arise from a background of atrophy or polyp rather than hyperplasia (76–80) and are not epidemiologically related to unopposed estrogen stimulation.

EIC has been proposed to represent a form of intraepithelial tumor characteristic of serous carcinoma, and it is the likely precursor to invasive serous carcinoma. EIC is usually found in the endometrium harboring a serous carcinoma (77,79), but occasionally occurs in the absence of any invasive carcinoma (81).

EIC is recognized as replacement of the surface epithelium or of portions of endometrial glands by a layer of malignant-appearing cells, 1–5 cells in thickness. The lesion is often present at a distance of several millimeters from the invasive carcinoma, and is interspersed among atrophic appearing glands or surface epithelium. Papillary tufting of the epithelium occurs in some cases, but a scalloped apical border of lining cells with highly pleomorphic nuclei is more common and most highly characteristic. Overexpression of p53 is found immunohistochemically in the epithelial cells of essentially all cases of both serous carcinoma and EIC, but is generally absent or weakly expressed in endometrioid carcinoma or hyperplasia (82). The histological similarity between EIC and invasive serous carcinoma and the frequent coexistence of EIC with serous carcinoma coupled with shared mutations in the p53 gene provide strong circumstantial evidence of a pathogenetic relationship (77,78). The other highly aggressive histological cell type of endometrial adenocarcinoma is the clear cell carcinoma, the precursor lesion of which has not been defined to date.

### 3. THE BIOLOGY AND THERAPY OF ADVANCED ENDOMETRIAL ADENOCARCINOMA

Based on histological or clinical variables from surgicopathological studies, several models have been created that predict the probability of spreading to regional lymph nodes, recurrence of tumor, or death from disease (20,83–90). Age, cell type, histological grade, lymphatic or capillary invasion, depth of myometrial invasion, help to predict advanced disease. Whereas surgical stage, age, depth of myometrial invasion, ploidy, and steroid receptor status assist in estimating the probability of recurrence and death from tumor. These prognostic variables reflect varying biological import. As the cell type and histological grade of a tumor are statistically significant prognosticators only before adjusting for International Federation of Gynecologists and Obstetricians FIGO stage, it is evident that they serve as markers of the inherent aggressiveness of a tumor and potential for spread. The depth of myometrial invasion and presence of lymphatic or capillary space involvement are related to the factor that a tumor has to gain access to regional nodes, whereas the surgical stage defines the observed spread of the tumor. Extrauterine spread of tumor generally precludes a surgical cure. Age is one of the most significant prognosticators of disease free survival even after adjustment for stage, but the mechanism remains speculative, perhaps reflecting the opportunity for a neoplasm to accumulate a higher number of deleterious mutations.

#### *3.1. Differences in Disease Progression Between the Two Types of Endometrial Adenocarcinoma*

The timing and pattern of metastatic dissemination of endometrial adenocarcinoma varies in part related to the histological cell type. Based on clinical observations, the sequence in the progression of endometrioid adenocarcinoma seems to be as follows:

1. Years of endogenous or exogenous hyperestrogenism associated with hyperplasia of increasing architectural complexity and cytological atypia;



2. Evolution of a clonal population often with a mutation in the *PTEN* gene, accompanied by histological features of adenocarcinoma (91);
3. A slow increase in the mass of carcinoma, with progressively deeper myometrial invasion and mechanical spread to the surface of the uterine cervix by exfoliation and superficial implantation, or direct spread to the cervical stroma as the mass of tumor increases in three dimensions;
4. Permeation of capillary or lymphatic spaces;
5.
  - a. Metastases to the regional (pelvic and para-aortic) lymph nodes or retrograde spread to the vagina.
  - b. Penetration of the uterine serosa or reflux of neoplastic cells through the fallopian tubes with spread to the ovaries or upper abdomen.
6. Eventual distant metastases.

In contrast is the typical progression of UPSC, which differs as follows:

1. The development (in a women typically 10 years older than one with endometrioid adenocarcinoma) of EIC with mutant p53 and wild-type PTEN in the absence of hyperestrinism and instead in a background of atrophy or polyp;
2.
  - a. Probable rapid progression to invasive UPSC.
  - b. Reflux of neoplastic cells through the fallopian tubes.
3.
  - a. Increase in tumor mass with spread to the cervical surface or stroma.
  - b. Implantation and growth of neoplastic cells on the pelvic peritoneum.
4.
  - a. Invasion into the myometrium usually accompanied by capillary or lymphatic invasion.
5.
  - a. Metastasis to regional (pelvic or para-aortic) lymph nodes.
  - b. Direct mechanical dissemination to other intraperitoneal sites, such as omentum and the surface of the diaphragm and liver.
6. Distant metastasis.

Either the (a) or (b) pathways, and frequently both, might occur for any given tumor. It is common for UPSC to have extended beyond the uterus to involve the peritoneum at the time of initial diagnosis. Indeed, the tumor may metastasize, presumably by a mechanism that includes exfoliation of neoplastic cells and trans-tubal reflux, whereas histologically still an *in situ* process (92).

Not all of the second type of endometrial carcinomas behave in the same fashion. Clear cell carcinoma also has an aggressive behavior, with an overall 5-year survival rate of about 40–50% (45,48,49,93–96). However, it differs from both endometrioid adenocarcinoma and UPSC, with frequent early lymphatic invasion and nodal spread, but without the propensity to spread by direct exfoliation and implantation on peritoneal surfaces. Although women with tumors confined to the endometrium have an approx 90% 5-year survival, deep myometrial invasion or vascular invasion carries a poor prognosis.

### ***3.2. Current Therapeutic Modalities for Advanced Stage and Recurrent Disease***

Since 1988, the staging of carcinoma of endometrium has been based on surgical-pathological features (97). A highly abbreviated description of the stages is as follows: stage I—tumor that is confined to the uterine corpus; stage II—tumor that involves the uterine corpus with spread to the uterine cervix; stage III—tumor, which has spread to the uterine serosa or adnexa, is identified in pelvic washing cytology, or involves pelvic or para-aortic lymph nodes; stage IV—tumor that has invaded the bowel or bladder mucosa or metastasized to distant sites. Early stage tumors are further divided according

to the presence and depth of myometrial invasion and the histological grade. Prognostication and therapy of endometrial adenocarcinoma are directly related to the stage of disease. The primary treatment of endometrial adenocarcinoma consists of hysterectomy and bilateral salpingo-oophorectomy. Pelvic and para-aortic lymph node sampling is indicated for some patients, largely based on the presence of high risk factors in the initial diagnostic endometrial sample. Additional surgery, including omentectomy and multiple peritoneal biopsies is often added for women with UPSC, as peritoneal spread is so common. Patients with endometrial adenocarcinoma, found to have adnexal spread, or pelvic or para-aortic lymph node metastasis at surgery, are at high risk for recurrence. They generally benefit from directed radiation therapy with 5-year survival rates of 35–85% based on the site of extrauterine disease (86,98).

Radiotherapy may also be effective when recurrent endometrial adenocarcinoma is later identified in the vagina or pelvis. In several studies, isolated vaginal recurrences treated with radiation therapy were associated with survival rates of about 40% for 5 or 10 years. But the rate dropped to about 20% when there was recurrent disease in the pelvis, and there were very few survivors with nodal recurrences (99–101). However, most women with either recurrent tumor or multifocal, large volume residual disease after surgery requires some form of systemic therapy, such as chemotherapy or hormonal therapy. Although, it must be acknowledged that these therapies are rarely curative and generally associated with disappointingly low response rates usually of short duration.

In single agent trials, cisplatin, carboplatin, doxorubicin, epirubicin, and paclitaxel each displayed some activity, with response rates usually in the range of 20–25%, the time to progression averaging only about 4–6 months, and the median survival averaging about 10 months (102). The combination of cisplatin and doxorubicin resulted in an increase in the response rate to about 50% and median survivals of about 1 year (102), whereas cisplatin and paclitaxel produces a response in 60–80%.

Estrogens and progesterone cause the proliferation and differentiation of glandular epithelium in the normal menstrual cycle, respectively. As most endometrial adenocarcinomas contain steroid receptors as measured by either biochemical or immunohistochemical assay, therapy with a steroid that inhibits cell proliferation would appear logical. In 1965, Kistner observed a histological response in endometrial adenocarcinoma in some women who were treated with progestins (103). More recently, Randall et al. have shown a 75–90% regression of complex atypical hyperplasia and well-differentiated adenocarcinoma in women under the age of 40 who were treated with oral progestin therapy. Similar results were reported by Montz et al. for perimenopausal women with well-differentiated adenocarcinoma using a progesterone-releasing intrauterine contraceptive device (104). Less favorable response rates of 15–35% have been observed for women with measurable recurrent tumors treated with any of the variety of progestational or antiestrogenic compounds (102,105). Progression of disease typically occurs after about 4 months of therapy and overall survival averages less than 12 months, although there are rare durable complete responses. The duration of the response to progestin therapy might be limited by the physiological effect that progesterone has on rapid downregulation of its own receptor. Based on animal model data in which tamoxifen was found to upregulate ER and PR with less stimulation of growth than estradiol, Mortel et al. (106,107) proposed that continuous administration of tamoxifen and alternating week therapy with

medroxyprogesterone acetate might help to increase both the rate and duration of response. In a recent study (108), this strategy produced clinical results that were not dramatically different from pure progestin therapy. Although, hormonal therapy for endometrial adenocarcinoma has been used for more than 40 years, surprisingly little is known about the mechanisms by which progestins produce their response in patients. It is even uncertain whether the effect is associated with apoptotic or necrotic cell death or terminal cell differentiation. Selective estrogen receptor modulators including tamoxifen have also been studied as single agent therapy, with results similar to that of progestins (102). Herceptin is currently being studied in women with recurrent tumors that overexpress the Her 2/neu molecule.

#### 4. CONCLUSIONS AND FUTURE DIRECTIONS

Frustration and optimism are equally appropriate responses on learning about the current state of knowledge about endometrial adenocarcinoma and its precursors. The following observations are accompanied by selected assertions and opinions that may provoke others and stimulate future research proposals:

1. The current WHO classification of endometrial precursor lesions (simple and complex, typical and atypical hyperplasia) is probably conceptually inaccurate and poorly reproducible. Most of these lesions are hyperplastic, but some are neoplastic. An alternative classification scheme that is both conceptually accurate and highly reproducible is needed.
2. The hysterectomy specimen obtained following the diagnosis of atypical hyperplasia frequently contains endometrial adenocarcinoma. Consequently, nonsurgical therapies for atypical hyperplasia should also be acceptable treatment for early stage endometrial adenocarcinoma. Treatment strategies currently are limited to progestational or antiestrogenic agents, and they are effective in a subset of precursor lesions. However, the mechanisms and pathways by which progestins act remains incompletely understood. Other forms of differentiating agents or molecules that correct aberrant pathways need to be identified.
3. The EIN scheme of precursor lesions to endometrioid adenocarcinoma based on a combination of morphometry and clonal analysis is probably conceptually accurate. Lesions recognized as EIN are probably preinvasive neoplasms, and about one half of EIN lesions contain mutations in PTEN. The ability of pathologists to subjectively mimic the classification has yet to be established.
4. EIC represents the immediate precursor lesion to invasive UPSC, and probably is a noninvasive neoplasm. In cases in which EIC and UPSC coexist in the endometrium, they share the same mutation in p53.
5. Endometrial adenocarcinoma can be divided into two broad types, with differing epidemiology, risk factors, mutations, precursor lesions, histological appearances, and biological behavior.
6. Endometrial adenocarcinoma can be further subdivided based on histological features into about six cell types. Some of the cell types also have distinctive epidemiology, risk factors, precursor lesions, histological appearances, and biological behavior. These cell types intrinsically do not have biological significance, but instead probably are secondarily associated with differing mutations that affect proliferation or differentiation pathways. Alternate classifications that offer better discrimination of biological behavior and patterns of metastasis could be provided by a system based on gene or protein expression analyses.

7. The majority of invasive endometrial adenocarcinomas can be cured by surgery including hysterectomy and bilateral salpingo-oophorectomy. Some women with small volume advanced disease in the lymph nodes or adnexa, or with localized vaginal vault recurrences may be cured with radiation therapy.
8. Pathologists and gynecological oncologists have identified clinical and histological features that can be used to create models that are very useful for prognostication. Patients at low, intermediate, and high risk of recurrence can be identified with relatively high accuracy. Pelvic radiation can reduce the incidence of local recurrence, but effective therapy does not exist for those who suffer tumor recurrence.
9. Chemotherapy for recurrent endometrial adenocarcinoma using multiple agents is largely palliative, with relatively low rates and short duration of response. It is unlikely that any chemotherapeutic program alone will be curative.
10. Hormonal therapy for recurrent endometrial adenocarcinoma is also palliative, with low response rates of generally short duration. As currently administered, it is very unlikely that any hormonal therapy will be curative.
11. Given the inability of any current modality to cure most women with recurrent endometrial adenocarcinoma, other forms of treatment should be aggressively pursued. Obvious potential targets include *PTEN*, *p53*, *Her-2/neu*, because these genes are mutated relatively often in different types of endometrial adenocarcinoma.

Knowledge of the pathways that are altered in various tumor types defined by gene expression analysis will probably provide better targets for antibody or gene directed therapy. Creation of tumor tissue and serum banks will be critical to the identification of both tumor classifications (molecular signatures) and their appropriate therapy.

## REFERENCES

1. Jemal A, Thomas A, Murray T, Thun M. Cancer Statistics. *CA Cancer J Clin* 2002; 52(1): 23–45.
2. Farhi D, Nosanchuk J, Silverberg S. Endometrial adenocarcinoma in women under 25 years of age. *Obstet Gynecol* 1986; 68: 741–745.
3. Gallup D, Stock R. Adenocarcinoma of the endometrium in women 40 years of age or younger. *Obstet Gynecol* 1984; 64: 417–420.
4. Brinton L, Hoover R. Epidemiology of gynecologic cancers. In: *Principles and practice of gynecologic oncology* (Hoskins W, Perez C, Young R, eds.), 3rd ed., Philadelphia: Lippincott, Williams and Wilkins, 2000, pp. 3–26.
5. Brinton LA, Hoover RN. Estrogen replacement therapy and endometrial cancer risk: unresolved issues. The Endometrial Cancer Collaborative Group. *Obstet Gynecol* 1993; 81(2): 265–271.
6. Castellsague X, Thompson WD, Dubrow R. Intra-uterine contraception and the risk of endometrial cancer. *Int J Cancer* 1993; 54(6): 911–916.
7. Kvale G, Heuch I, Ursin G. Reproductive factors and risk of cancer of the uterine corpus: a prospective study. *Cancer Res* 1988; 48(21): 6217–6221.
8. Nyholm HC, Nielsen AL, Norup P. Endometrial cancer in postmenopausal women with and without previous estrogen replacement treatment: comparison of clinical and histopathological characteristics. *Gynecol Oncol* 1993; 49(2): 229–235.
9. Schwartzbaum JA, Hulka BS, Fowler W Jr, Kaufman DG, Hoberman D. The influence of exogenous estrogen use on survival after diagnosis of endometrial cancer. *Am J Epidemiol* 1987; 126(5): 851–860.
10. Horwitz R, Feinstein A, Horwitz S, Robboy S. Necropsy diagnosis of endometrial cancer and detection-bias in case-control studies. *Lancet* 1981; 2: 66–68.
11. Fornander T, Cedarmark B, Mattson A. Adjuvant tamoxifen in early breast cancer: occurrence of new primary cancers. *Lancet* 1989; 21: 117–119.
12. Fisher B, Constantino J, Redmond CK, et al. Endometrial cancer in tamoxifen-treated breast cancer patients: findings from the National Surgical Adjuvant Breast and Bowel Project (NSABP) B14. *J Natl Cancer Inst* 1994; 86: 527–531.

13. Magriples U, Naftolin F, Schwartz P, Carcangiu M. High-grade endometrial carcinoma in tamoxifen-treated breast cancer patients. *J Clin Oncol* 1993; 11: 485–490.
14. Barakat R, Wong G, Curtin J, Vlamis V, Hoskins W. Tamoxifen use in breast cancer patients who subsequently develop corpus cancer is not associated with a higher incidence in adverse histologic features. *Gynecol Oncol* 1994; 55: 164–168.
15. Watson P, Vasen H, Mecklin J, Jarvinen H, Lynch H. The risk of endometrial cancer in hereditary nonpolyposis colorectal cancer. *Am J Med* 1994; 96: 516–520.
16. Bokhman J. Two pathogenetic types of endometrial carcinoma. *Gynecol Oncol* 1983; 15: 10–17.
17. Deligdisch L, Cohen CJ. Histologic correlates and virulence implications of endometrial carcinoma associated with adenomatous hyperplasia. *Cancer* 1985; 56(6): p1452–p1455.
18. Deligdisch L, Holinka C. Progesterone receptors in two groups of endometrial carcinoma. *Cancer* 1986; 57: 1385–1388.
19. Silverberg S, Kurman R. Tumors of the Uterine Corpus and Gestational Trophoblastic Disease. Washington: Armed Forces Institute of Pathology; 1992, p27–p40.
20. Abeler V, Kjordstad K, Berle E. Carcinoma of the endometrium in Norway: a histopathological and prognostic survey of a total population. *Int J Gynecol Cancer* 1992; 2: 9–22.
21. Fanning J, Evans MC, Peters AJ, Samuel M, Harmon ER, Bates JS. Endometrial adenocarcinoma histologic subtypes: clinical and pathologic profile. *Gynecol Oncol* 1989; 32(3): 288–291.
22. Zaino R, Kurman R, Herbold D, et al. The significance of squamous differentiation in endometrial carcinoma. *Cancer* 1991; 68: 2293–2302.
23. Zaino RJ, Kurman RJ. Squamous differentiation in carcinoma of the endometrium: a critical appraisal of adenoacanthoma and adenosquamous carcinoma. *Semin Diagn Pathol* 1988; 5(2): 154–171.
24. Melhem MF, Tobon H. Mucinous adenocarcinoma of the endometrium: a clinico-pathological review of 18 cases. *Int J Gynecol Pathol* 1987; 6(4): 347–355.
25. Ross J, Eifel P, Cox R, Kempson R, Hendrickson M. Primary mucinous adenocarcinoma of the endometrium. *Am J Surg Pathol* 1983; 7: 715–729.
26. Tiltman A. Mucinous carcinoma of the endometrium. *Obstet Gynecol* 1980; 55: 244–247.
27. Abeler VM, Kjordstad KE. Serous papillary carcinoma of the endometrium: a histopathological study of 22 cases. *Gynecol Oncol* 1990; 39(3): 266–271.
28. Ambros RA, Ballouk F, Malfetano JH, Ross JS. Significance of papillary (villoglandular) differentiation in endometrioid carcinoma of the uterus. *Am J Surg Pathol* 1994; 18(6): p569–p575.
29. Carcangiu ML, Chambers JT. Uterine papillary serous carcinoma: a study on 108 cases with emphasis on the prognostic significance of associated endometrioid carcinoma, absence of invasion, and concomitant ovarian carcinoma. *Gynecol Oncol* 1992; 47(3): 298–305.
30. Chen J, Trost D, Wilkinson E. Endometrial papillary adenocarcinomas: two clinicopathologic types. *Int J Gynecol Pathol* 1985; 4: 279–288.
31. Christopherson W, Alberhasky R, Connelly P. Carcinoma of the endometrium II. Papillary adenocarcinoma: a clinicopathological study of 46 cases. *Am J Clin Pathol* 1982; 77: 534–540.
32. Gallion HH, van NJ Jr, Powell DF, et al. Stage I serous papillary carcinoma of the endometrium. *Cancer* 1989; 63(11): 2224–2228.
33. Hendrickson M, Martinez A, Ross J, Kempson R, Eifel P. Uterine papillary serous carcinoma: a highly malignant form of endometrial adenocarcinoma. *Am J Surg Pathol* 1982; 6: 93–108.
34. Lauchlan S. Tubal (serous) carcinoma of the endometrium. *Arch Pathol Lab Med* 1981; 105: 615–618.
35. Silva EG, Jenkins R. Serous carcinoma in endometrial polyps. *Mod Pathol* 1990; 3(2): 120–128.
36. Sutton GP, Brill L, Michael H, Stehman FB, Ehrlich CE. Malignant papillary lesions of the endometrium. *Gynecol Oncol* 1987; 27(3): 294–304.
37. Ward BG, Wright RG, Free K. Papillary carcinomas of the endometrium. *Gynecol Oncol* 1990; 39(3): 347–351.
38. Cirisano F, Robboy S, Dodge R, et al. Epidemiologic and surgicopathologic findings of papillary serous and clear cell endometrial cancers when compared to endometrioid carcinoma. *Gynecol Oncol* 1999; 74(3): p385–p394.
39. Grice J, Ek M, Greer B, et al. Uterine papillary serous carcinoma: evaluation of long-term survival in surgically staged patients. *Gynecol Oncol* 1998; 69(1): p69–p73.
40. Lee K, Belinson J. Papillary serous adenocarcinoma of the endometrium: a clinicopathologic study of 19 cases. *Gynecol Oncol* 1992; 46(1): p51–p54.
41. Mallipeddi P, Kapp D, Teng N. Long-term survival with adjuvant whole abdominopelvic irradiation for uterine papillary serous carcinoma. *Cancer* 1993; 71(10): p3076–p3081.

42. Sakuragi N, Hareyama H, Todo Y, et al. Prognostic significance of serous and clear cell adenocarcinoma in surgically staged endometrial carcinoma. *Acta Obstet Gynecol Scand* 2000; 79(4): p311–p316.
43. Sutton G, Brill L, Michael H, Stehman F, Ehrlich C. Malignant papillary lesions of the endometrium. *Gynecol Oncol* 1987; 27(3): p294–p304.
44. Abeler VM, Kjorstad KE. Clear cell carcinoma of the endometrium: a histopathological and clinical study of 97 cases. *Gynecol Oncol* 1991; 40(3): p207–p217.
45. Abeler VM, Vergote IB, Kjorstad KE, Trope CG. Clear cell carcinoma of the endometrium. Prognosis and metastatic pattern. *Cancer* 1996; 78(8): p1740–p1747.
46. Christopherson WM, Alberhasky RC, Connelly PJ. Carcinoma of the endometrium: I. A clinicopathologic study of clear-cell carcinoma and secretory carcinoma. *Cancer* 1982; 49(8): p1511–p1523.
47. Lax SF, Pizer ES, Ronnett BM, Kurman RJ. Clear cell carcinoma of the endometrium is characterized by a distinctive profile of p53, Ki-67, estrogen, and progesterone receptor expression. *Hum Pathol* 1998; 29(6): p551–p558.
48. Webb GA, Lagios MD. Clear cell carcinoma of the endometrium. *Am J Obstet Gynecol* 1987; 156(6): p1486–p1491.
49. Abeler VM, Kjorstad KE. Endometrial adenocarcinoma in Norway. A study of a total population. *Cancer* 1991; 67(12): 3093–3103.
50. Cullen T. Cancer of the uterus: *its pathology, symptomatology, diagnosis and treatment*. New York: Appleton; 1900, p6–p30.
51. Eichhorn JH, Young RH, Clement PB. Sertoliform endometrial adenocarcinoma: a study of four cases. *Int J Gynecol Pathol* 1996; 15(2): p119–p126.
52. Beutler H, Dockerty M, Randall L. Precancerous lesions of the endometrium. *Am J Obstet Gynecol* 1963; 86: 433–443.
53. Campbell P, Barter R. The significance of atypical endometrial hyperplasia. *J Obstet Gynaecol Br Commonw* 1961; 68: 668–672.
54. Gusberg S, Al K. Precursors of corpus cancer:IV. adenomatous hyperplasia as stage 0 carcinoma of the endometrium. *Am J Obstet Gynecol* 1963; 87: 662–676.
55. Gore H, Hertig A. Carcinoma *in situ* of the endometrium. *Am J Obstet Gynecol* 1966; 94: 135–155.
56. Hendrickson M, Kempson R. *Surgical pathology of the uterine corpus*. Philadelphia: WB Saunders Co., 1980, 285–318.
57. Kurman R, Kaminski P, Norris H. The behavior of endometrial hyperplasia. A long-term study of “untreated” hyperplasia in 170 patients. *Cancer* 1985; 56: 403–411.
58. Tavassoli F, Kraus F. Endometrial lesions in uteri resected for atypical endometrial hyperplasia. *Am J Clin Pathol* 1978; 70: 770–779.
59. Vellios F. Endometrial hyperplasia, precursors of endometrial carcinoma. *Pathol Annu* 1972; 7: 201–229.
60. Kendall BS, Ronnett BM, Isacson C, et al. Reproducibility of the diagnosis of endometrial hyperplasia, atypical hyperplasia, and well-differentiated carcinoma. *Am J Surg Pathol* 1998; 22(8): p1012–p1019.
61. Skov BG, Broholm H, Engel U, et al. Comparison of the reproducibility of the WHO classifications of 1975 and 1994 of endometrial hyperplasia. *Int J Gynecol Pathol* 1997; 16(1): p33–p37.
62. Bergeron C, Nogales F, Masseroli M, et al. A multicentric European study testing the reproducibility of the WHO classification of endometrial hyperplasia with a proposal of a simplified working classification for biopsy and curettage specimens. *Am J Surg Pathol* 1999; 23: 1102–1108.
63. Colgan T, Norris H, Foster W, Kurman R, Fox C. Predicting the outcome of endometrial hyperplasia by quantitative analysis of nuclear features using a linear discriminant function. *Int J Gynecol Pathol* 1983; 1: 347–352.
64. Baak J. The use and disuse of morphometry in the diagnosis of endometrial hyperplasia and carcinoma. *Path Res Pract* 1984; 179: 20–23.
65. Baak JP. Further evaluation of the practical applicability of nuclear morphometry for the prediction of the outcome of atypical endometrial hyperplasia. *Anal Quant Cytol Histol* 1986; 8(1): p46–p48.
66. Baak JP, Nauta JJ, Wisse-Brekelmans EC, Bezemer PD. Architectural and nuclear morphometrical features together are more important prognosticators in endometrial hyperplasias than nuclear morphometrical features alone. *J Pathol* 1988; 154(4): p335–p341.
67. Baak JP. The role of computerized morphometric and cytometric feature analysis in endometrial hyperplasia and cancer prognosis. *J Cell Biochem Suppl* 1995; 23: 137–146.
68. Ausems EW, van der Kamp JK, Baak JP. Nuclear morphometry in the determination of the prognosis of marked atypical endometrial hyperplasia. *Int J Gynecol Pathol* 1985; 4(3): p180–p185.

69. Baak JP, Wisse-Brekemans EC, Fleege JC, van der Putten HW, Bezemer PD. Assessment of the risk on endometrial cancer in hyperplasia, by means of morphological and morphometrical features. *Pathol Res Pract* 1992; 188(7): p856–p859.
70. Norris HJ, Becker RL, Mikel UV. A comparative morphometric and cytophotometric study of endometrial hyperplasia, atypical hyperplasia, and endometrial carcinoma. *Hum Pathol* 1989; 20(3): p219–p223.
71. Dunton CJ, Baak JP, Palazzo JP, van Diest PJ, McHugh M, Widra EA. Use of computerized morphometric analyses of endometrial hyperplasias in the prediction of coexistent cancer. *Am J Obstet Gynecol* 1996; 174(5): p1518–p1521.
72. Jovanovic A, Boynton K, Mutter G. Uteri of women with endometrial carcinoma contain a histopathological spectrum of monoclonal putative precursors, some with microsatellite instability. *Cancer Res* 1996; 56: 1917–1921.
73. Mutter GL, Chaponot ML, Fletcher JA. A polymerase chain reaction assay for non-random X chromosome inactivation identifies monoclonal endometrial cancers and precancers. *Am J Pathol* 1995; 146(2): p501–p508.
74. Mutter G, Baak J, Crum C, Richart R, Ferenczy A, Faquin W. Endometrial precancer diagnosis by histopathology, clonal analysis, and computerized morphometry. *J Pathol* 2000; 190: 462–469.
75. Mutter GL. Endometrial intraepithelial neoplasia (EIN): will it bring order to chaos? The Endometrial Collaborative Group. *Gynecol Oncol* 2000; 76(3): p287–p290.
76. Ambros RA, Sherman ME, Zahn CM, Bitterman P, Kurman RJ. Endometrial intraepithelial carcinoma: a distinctive lesion specifically associated with tumors displaying serous differentiation. *Hum Pathol* 1995; 26(11): p1260–p1267.
77. Sherman M. Theories of endometrial carcinogenesis: a multidisciplinary approach. *Mod Pathol* 2000; 13(3): p295–p308.
78. Sherman M, Bur M, Kurman R. p53 in endometrial cancer and its putative precursors: evidence for diverse pathways of tumorigenesis. *Hum Pathol* 1995; 26(11): p1268–p1274.
79. Sherman ME, Bitterman P, Rosenshein NB, Delgado G, Kurman RJ. Uterine serous carcinoma. A morphologically diverse neoplasm with unifying clinicopathologic features. *Am J Surg Pathol* 1992; 16(6): 600–610.
80. Spiegel G. Endometrial carcinoma *in situ* in postmenopausal women. *Am J Surg Pathol* 1995; 19: 417–431.
81. Tashiro H, Isacson C, Levine R, Kurman R, Cho K, Hedrick L. p53 gene mutations are common in uterine serous carcinoma and occur early in their pathogenesis. *Am J Pathol* 1997; 150(1): p177–p185.
82. Zheng W, Cao P, Zheng M, Kramer E, Godwin T. p53 overexpression and bcl-2 persistence in endometrial carcinoma: comparison of papillary serous and endometrioid subtypes. *Gynecol Oncol* 1996; 61(2): p167–p174.
83. Creasman WT, Morrow CP, Bundy BN, Homesley HD, Graham JE, Heller PB. Surgical pathologic spread patterns of endometrial cancer. A Gynecologic Oncology Group Study. *Cancer* 1987; 60(Suppl 8): 2035–2041.
84. Homesley H, Zaino R. Endometrial cancer: prognostic factors. *Semin Oncol* 1994; 21: 71–78.
85. Lampe B, Kurzl R, Hantschmann P. Reliability of tumor typing of endometrial carcinoma in prehisterectomy curettage. *Int J Gynecol Pathol* 1995; 14: 2–6.
86. Morrow CP, Bundy BN, Kurman RJ, et al. Relationship between surgical-pathological risk factors and outcome in clinical stage I and II carcinoma of the endometrium: a Gynecologic Oncology Group study. *Gynecol Oncol* 1991; 40(1): 55–65.
87. Zaino RJ, Kurman RJ, Diana KL, Morrow CP. Pathologic models to predict outcome for women with endometrial adenocarcinoma: the importance of the distinction between surgical stage and clinical stage—a Gynecologic Oncology Group study. *Cancer* 1996; 77(6): p1115–p1121.
88. Zaino RJ. Conventional and novel prognostic factors in endometrial adenocarcinoma: a critical appraisal. *Pathol Case Rev* 2000; 5(3): 138–152.
89. Mariani A, Webb M, Keeney G, Aletti G, Podratz K. Assessment of prognostic factors in Stage IIIA endometrial cancer. *Gynecol Oncol* 2001; 86: 38–44.
90. Mariani A, Webb M, Keeney G, Lesnick T, Podratz K. Surgical Stage I endometrial cancer: predictors of distant failure and death. *Gynecol Oncol* 2002; 87: 274–280.
91. Daniel AG, Peters WD. Accuracy of office and operating room curettage in the grading of endometrial carcinoma. *Obstet Gynecol* 1988; 71(4): 612–614.
92. Wheeler D, Bell K, Kurman R, Sherman M. Minimal uterine serous carcinoma: diagnostic and clinicopathologic correlation. *Am J Surg Pathol* 2000; 24: 797–806.

93. Aquino-Parsons C, Lim P, Wong F, Mildenberger M. Papillary serous and clear cell carcinoma limited to endometrial curetings in FIGO stage 1a and 1b endometrial adenocarcinoma: treatment implications. *Gynecol Oncol* 1998; 71(1): p83–p86.
94. Carcangiu ML, Chambers JT. Early pathologic stage clear cell carcinoma and uterine papillary serous carcinoma of the endometrium: comparison of clinicopathologic features and survival. *Int J Gynecol Pathol* 1995; 14(1): p30–p38.
95. Kanbour-Shakir A, Tobon H. Primary clear cell carcinoma of the endometrium: a clinicopathologic study of 20 cases. *Int J Gynecol Pathol* 1991; 10(1): p67–p78.
96. Malpica A, Tornos C, Burke TW, Silva EG. Low-stage clear-cell carcinoma of the endometrium. *Am J Surg Pathol* 1995; 19(7): p769–p774.
97. Creasman WI. FIGO stages-1988 revision. *Gynecol Oncol* 1989; 35: 125–126.
98. Potish R, Twigg L, Adcock L, et al. Para-aortic lymph node therapy in cancer of the uterine corpus. *Obstet Gynecol* 1985; 65(4): 251–257.
99. Aalders J, Abeler V, Kolstad P. Recurrent adenocarcinoma of the endometrium: a clinical and histopathological study of 379 patients. *Gynecol Oncol* 1984; 17: 85–92.
100. Kuten A, Grigsby P, Perez C, Fineberg B, Garcia D, Simpson J. Results of radiotherapy in recurrent endometrial carcinoma. *Int J Radiat Oncol Biol Phys* 1989; 17: 29–36.
101. Poulsen M, Roberts S. The salvage of recurrent endometrial carcinoma in the vagina and pelvis. *Int J Radiat Oncol Biol Phys* 1988; 15: 809–814.
102. Barakat R, Grigsby P, Sabatini P, Zaino R. Corpus: epithelial tumors. In: *Principles and Practice of Gynecologic Oncology*. (Hoskins W, Perez C, Young R, eds.), 3rd ed., Lippincott, William and Wilkins, Philadelphia, 2000, pp. 921–955.
103. Kistner R, Griffiths C, Craig J. Use of progestational agents in the management of endometrial cancer. *Cancer* 1965; 18: 1563–1579.
104. Montz F, Bristow R, Bovicelli A, Tomacruz R, Kurman R. Intrauterine progesterone treatment of early endometrial cancer. *Am J Obstet Gynecol* 2002; 186: 651–657.
105. Thigpen JT, Brady MF, Alvarez RD, et al. Oral medroxyprogesterone acetate in the treatment of advanced or recurrent endometrial carcinoma: a dose-response study by the Gynecologic Oncology Group. *J Clin Oncol* 1999; 17: 1736–1744.
106. Mortel R, Zaino RJ, Satyaswaroop PG. Designing a schedule of progestin administration in the control of endometrial carcinoma growth in the nude mouse model. *Am J Obstet Gynecol* 1990; 162: 928–934.
107. Satyaswaroop PG, Clarke CL, Zaino RJ, Mortel R. Apparent resistance in human endometrial carcinoma during combination treatment with tamoxifen and progestin may result from desensitization following downregulation of tumor progesterone receptor. *Cancer Lett* 1992; 62: 107–114.
108. Whitney CW, Brunetto VL, Zaino RJ, et al. Phase II study of medroxyprogesterone acetate plus tamoxifen in advanced endometrial carcinoma: a Gynecologic Oncology Group study. *Gynecol Oncol* 2004; 92: 4–9.



# 5

---

## Endometrial Carcinogenesis

*An Integrated, Molecular, Histological,  
and Functional Model of a Dualistic Disease*

---

*George L. Mutter, MD*

### CONTENTS

INTRODUCTION
CLINICOPATHOLOGICAL TYPES OF ENDOMETRIAL ADENOCARCINOMA
SPORADIC AND HEREDITARY CONTEXT OF ENDOMETRIAL CARCINOMA
CLINICOPATHOLOGICAL AND MOLECULAR APPROACHES TO CARCINOGENESIS
PRECURSORS OF ENDOMETRIOID ENDOMETRIAL CARCINOMA
PRECURSORS OF NONENDOMETRIOID ENDOMETRIAL ADENOCARCINOMA
FUTURE IMPLICATIONS
REFERENCES

---

### 1. INTRODUCTION

Endometrial adenocarcinoma is a heterogeneous group of tumors with variable pathological, clinical, epidemiological, and genetic properties. Although, each of these perspectives contribute an aspect of understanding to the biology of this most common of all gynecological malignancies, they must be combined to achieve maximum benefit in patient care. This chapter is oriented along the simplified lines of a dichotomous model of sporadic disease in which the clinicopathological groups of endometrioid (type I) and nonendometrioid (type II) endometrial carcinomas are a launching point to consider their most commonly encountered characteristics. The former are subject to endocrine modulation and transit a *PTEN* tumor suppressor inactivated precursor stage of endometrial intraepithelial neoplasia (EIN), whereas the latter are characterized by *p53* inactivation and a brief, if any, premalignant phase. A potential mechanism of unopposed estrogen promotion of endometrial carcinogenesis is its positive selection for *PTEN*-mutant epithelial cells, enabling clonal expansion and subsequent accumulation

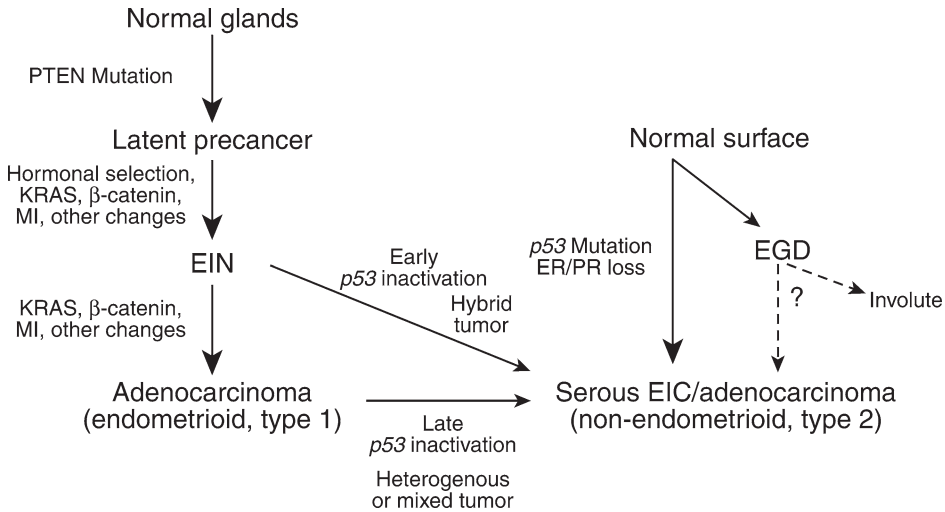

**Fig. 1.** Multiple roads to endometrial carcinoma. The phenotype of endometrial carcinoma is determined during carcinogenesis. Type I carcinomas inactivate PTEN very early on, before any discernible histological change (latent precancer). Nongenetic hormonal selection factors modulate cancer risk through their action on preclinical latent clones, which may undergo involution or expansion with additional mutation. Additional mutations are sometimes accelerated by a microsatellite instability phenotype, define stepwise progression events to endometrial intraepithelial neoplasia and then adenocarcinoma. Serous (type II) tumors are first seen as a short-lived preinvasive stage designated serous EIC. Endometrial glandular dysplasia is a newly described lesion with *p53* genotype and histology intermediate between normal and serous EIC. Progression and involution rates of endometrial glandular dysplasia lesions after sometime must be defined to determine how often they are actual precursors of type II cancers. Rarely, individual examples of type I tumors may acquire an early or late *p53* inactivation event, causing a hybrid or heterogenous tumor, respectively.

of additional mutations needed for progression from a latent or subclinical phase of disease, through EIN, to carcinoma. Cancer prevention and early diagnostic strategies suggested by this model have relevance to clinical management.

## 2. CLINICOPATHOLOGICAL TYPES OF ENDOMETRIAL ADENOCARCINOMA

Most endometrial adenocarcinomas fall into one of two clinicopathological groups (Fig. 1). Initially, defined by histopathological appearance (1) and natural history as “endometrioid” (type I) and “nonendometrioid”(type II) (2,3), this classification has subsequently been shown to be paralleled by systematic differences in molecular features (4,5). The majority, i.e., more than 95% of sporadic endometrial adenocarcinomas might be readily and easily assigned to one of these groups. Exceptions pose diagnostic dilemmas for the histopathologist, but reflect the reality of a subgroup of individual tumors that are not purely assignable to a cohesive subtype. A common example is the homogenous endometrioid tumor with an unexpected *P53* mutation throughout (Fig. 1, “hybrid” type), or the predominantly endometrioid tumor with a geographically delimited nonendometrioid subclone (Fig. 1, heterogenous or mixed type). For purposes of discussion, this chapter focusses primarily on the two major types of endometrial cancer.

Differences in endometrioid and nonendometrioid tumor classes are summarized in Table 1. Type I tumors usually have a nonaggressive behavior, and are often preceded

**Table 1**  
**Differences in Endometrioid and Nonendometrioid Subtypes**  
**of Endometrial Adenocarcinoma**

<i>Feature</i>	<i>Type I</i>	<i>Type II</i>	<i>References</i>
Alternate designation	Endometrioid	Nonendometrioid	–
Histology	Endometrial, mucinous, adenosquamous, secretory	Papillary serous, clear cell, carcinosarcoma	1
Grades	1–3	Not applicable	–
Behavior	Indolent	Aggressive	–
Risk factors	Endocrine (unopposed estrogen)	Unknown	–
Precursor lesion	EIN	?EGD, ?serous EIC	18,54,56
<i>p53</i> mutation	5–10%	80–90%	4,58
<i>PTEN</i> inactivation	55%	11%	8
K-ras inactivation	13–26	0–10%	28,51,58
$\beta$ -Catenin inactivation	25–38%	Rare	28
<i>MLH1</i> inactivation	17%	5%	9,10
Loss of estrogen and progesterone receptors	27–30%	76–81%	51

by high risk hormonal exposures (unopposed estrogens) (6) and a histologically discernible premalignant lesion, EIN (7). Prototypical type I tumors are prone to inactivation of the *PTEN* tumor suppressor gene (8) and a wide variety of ancillary molecular defects. In contrast, type II tumors occur in women who are slightly older (by 5–10 years) and are highly fatal (1). Molecular lesions within the nonendometrioid group are dominated by inactivation of the *p53* gene, a change present in almost 90% of cases (4). The patterns of genetic instability differ in significant ways. Type I tumors have a very specific type of genetic instability, mismatch repair defects, caused by epigenetic inactivation of mismatch repair factors, such as *MSH1* (9). Genetic instability in type II tumors is manifested globally at the chromosomal rather than microsatellite level, frequently demonstrating high order aneuploidy although having an intact mismatch repair mechanism (10,11).

### 3. SPORADIC AND HEREDITARY CONTEXT OF ENDOMETRIAL CARCINOMA

Rarely, endometrial carcinoma presents as an organ specific manifestation of a more generalized heritable tumor syndrome in which germline transmission of a mutant gene predisposes to endometrial carcinoma. The vast majority of endometrial carcinomas, more than 98%, are sporadic and occur outside of the context of a heritable syndromic presentation. Nonetheless, endometrial cancer syndromes are of interest because of the

need to provide genetic counseling to families of affected individuals and as examples of tumor sequelae of individual gene inactivation. Patients with hereditary defects of the PTEN (Cowden's syndrome) (8) or mismatch repair (Hereditary nonpolyposis colon cancer) (12,13) pathways have elevated endometrioid endometrial cancer rates.

#### **4. CLINICOPATHOLOGICAL AND MOLECULAR APPROACHES TO CARCINOGENESIS**

The events of carcinogenesis are determinative of subsequent tumor type and behavior. In this regard, dichotomous pathways of endometrial tumorigenesis corresponding to types I and II carcinomas are expected. These have sufficiently different mechanisms of origin and histological presentations that are best discussed separately. First, however, the background and general principles of precancer biology in the endometrium will be surveyed.

##### ***4.1. Endometrial "Hyperplasias," a Clinicopathologically Defined Precancer State***

It has been more than fifty years since Hertig first reported that women with endometrial cancer may have diagnosable precursor lesions that antedate cancer occurrence by several years (14). A clinical concept of premalignant disease based on heightened risk of cancer outcomes in women with endometrial "hyperplasias" quickly emerged as a diagnostic entity and therapeutic target (15,16). Statistical association of cancer outcome with presence or absence of atypical endometrial hyperplasia, as observed in study populations, became the basis for a cancer prevention strategy incorporating timely precancer diagnosis and ablation (16). In practice, classification into pure premalignant and benign categories using hyperplasia criteria was at best fuzzy, because of the subjective nature of the histological criteria discovery process, limited access to patients of defined clinical outcomes, and poor diagnostic reproducibility during implementation. This is a particular problem in the case of precursors to type I cancers, which are admixed in most study populations with "hyperplasias" caused by the systemic effects of prolonged estrogen exposure.

##### ***4.2. Molecular Resolution of Biologically Defined Premalignant Endometrial Lesions***

Routine histopathology was for long the only readily accessible diagnostic modality, a particular problem in a source tissue which demonstrates dramatic morphological plasticity in response to hormonal stimulation and life cycle changes. The capacity to resolve premalignant lesions in individual patients improved dramatically in the 1990s with the advent of a new molecular toolkit. A key advantage of this approach was the ability to use lesion-specific markers as a unique identifier for premalignant tissue. Specific genetic changes in putative premalignant lesions were confirmed to be carried forward in subsequent carcinomas, thereby confirming direct lineage continuity between premalignant and malignant phases of disease (17,18). For the first time, specific examples of premalignant disease could be confirmed and examined in individual patients.

Contemporary precancer models, which incorporate molecular, cellular, and clinical elements have driven many of the recent developments in the understanding of

**Tables 2**  
**Predicted Properties and Level of Evidence for Endometrial Premalignant Lesions**

<i>Predicted feature</i>	<i>EIN<sup>a</sup></i>	<i>EGD<sup>b</sup></i>	<i>Serous EIC<sup>c</sup></i>
Associated cancer type	Endometrioid (type I)	Nonendometrioid (type II)	Nonendometrioid (type II)
Difference from normal tissue	Monoclonal	Initial <i>p53</i> changes	<i>p53</i> mutations, cytology
Differ from carcinoma	Intermediate <i>PTEN</i> and microsatellite changes	Intermediate deletional and <i>p53</i> changes	Not shown
Continuous lineage to carcinoma	Multiple genetic markers confirm same clone	Same <i>p53</i> mutations	Same <i>p53</i> mutations
Can be diagnosed	Yes, morphometry or subjective histology	Probably. Must be distinguished from repair	Yes, histology and markers ( <i>p53</i> )
Increased cancer risk	89-fold	Unknown	Yes

<sup>a</sup>Endometrial intraepithelial neoplasia.

<sup>b</sup>Endometrial glandular dysplasia.

<sup>c</sup>Serous endometrial intraepithelial carcinoma.

endometrial carcinogenesis. Predicted biological properties of premalignant endometrial lesions are shown in Table 2, along with the level of existing evidence for candidate endometrial precursors, which have been proposed for types I and II carcinomas. This evidence has been combined in a flow diagram of lesion evolution in Fig. 1, incorporating previously unrecognized endometrial stages, such as “latent precancers” and “endometrial glandular dysplasia,” entities whose recognition depends on availability of suitable molecular markers. Caution must be exercised in assigning particular clinical significance to these preclinical lesions, as they might behave quite differently than their clinically diagnosable counterparts.

## 5. PRECURSORS OF ENDOMETRIOID ENDOMETRIAL CARCINOMA

Genesis of endometrioid carcinoma follows a classic multistep mutational model with corresponding sequential changes in histopathology (Fig. 2). The constellation and order of invocation, of affected genes and histopathological presentations vary between individual patients.

### 5.1. *PTEN* Changes

The most commonly altered gene is *PTEN*, a tumor suppressor gene which serves to modulate cell division rates and enable apoptosis (19). The proportion of endometrial carcinomas that demonstrate *PTEN* inactivation is dependent to a certain extent on case selection. The highest rate is 83%, seen in those sporadic endometrioid cancers associated with a coexisting or previous premalignant lesion (20). A functional link between endometrial carcinogenesis and *PTEN* inactivation is further supported by a 20% endometrial cancer rate in a constitutive murine *PTEN* knockout model (21). In humans

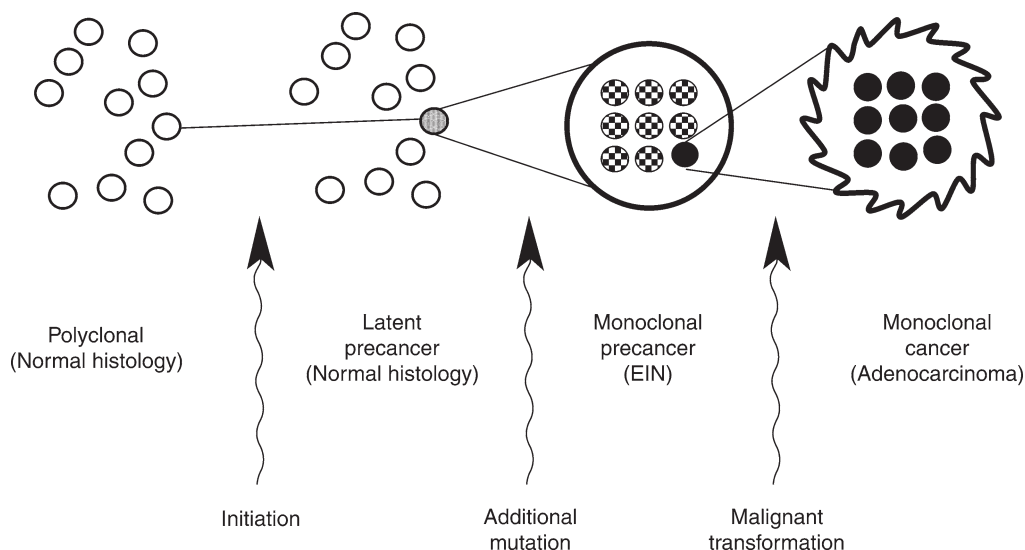

**Fig. 2.** A clonal model of endometrioid endometrial carcinogenesis. The first mutation which initiates carcinogenesis are within cells that maintain an appearance and behavior similar to normal, thus, their designation as “latent precancers.” The earliest morphologically distinguished premalignant lesion, endometrial intraepithelial neoplasia are generated through additional mutation and clonal expansion into a histological focus with altered cytology and architecture. Malignant transformation from endometrial intraepithelial neoplasia to adenocarcinoma is driven by further mutation and acquisition of an aggressive phenotype. Nongenetic factors can act as positive or negative selection factors for clonal expansion and/or survival, thereby altering probability of progression.

isolated *PTEN* inactivation is insufficient to induce endometrial carcinoma, requiring additional nongenetic and genetic factors to be invoked before progression to a malignant phase.

### 5.2. Latent (Preclinical) Phase of Carcinogenesis

The earliest detected genetic changes and somatically acquired endometrial gland mutations in the *PTEN* tumor suppressor gene are not accompanied by any cytological or architectural modifications evident at the light microscopic level (Fig. 3) (22). This “latent precancer” phase is subclinical in every respect, falling below the threshold of detection using routine diagnostic methods, and without a highly increased prospective cancer risk. It is presence or absence of local and systemic selection factors for subsequent clonal expansion or involution, which stratify patients into risk groups. In the latent phase, mutated cells may participate in successive endometrial regeneration during the course of many menstrual cycles, and demonstrate normal morphogenesis in conjunction with associated stroma.

Another early event, i.e., inactivation of mismatch repair mechanisms that result in a microsatellite instability (MI) phenotype, might also take place before acquisition of a specific histological phenotype (10) and is seen in 15–20% of endometrioid cancers (11,23). Epigenetic silencing of the *MLH1* gene through promoter methylation is the most common mechanism (24) of induction of MI. This form of genetic instability increases basal mutagenic rates, thereby accelerating acquisition of cumulative damage sufficient for malignant transformation. The majority of endometrioid carcinomas,

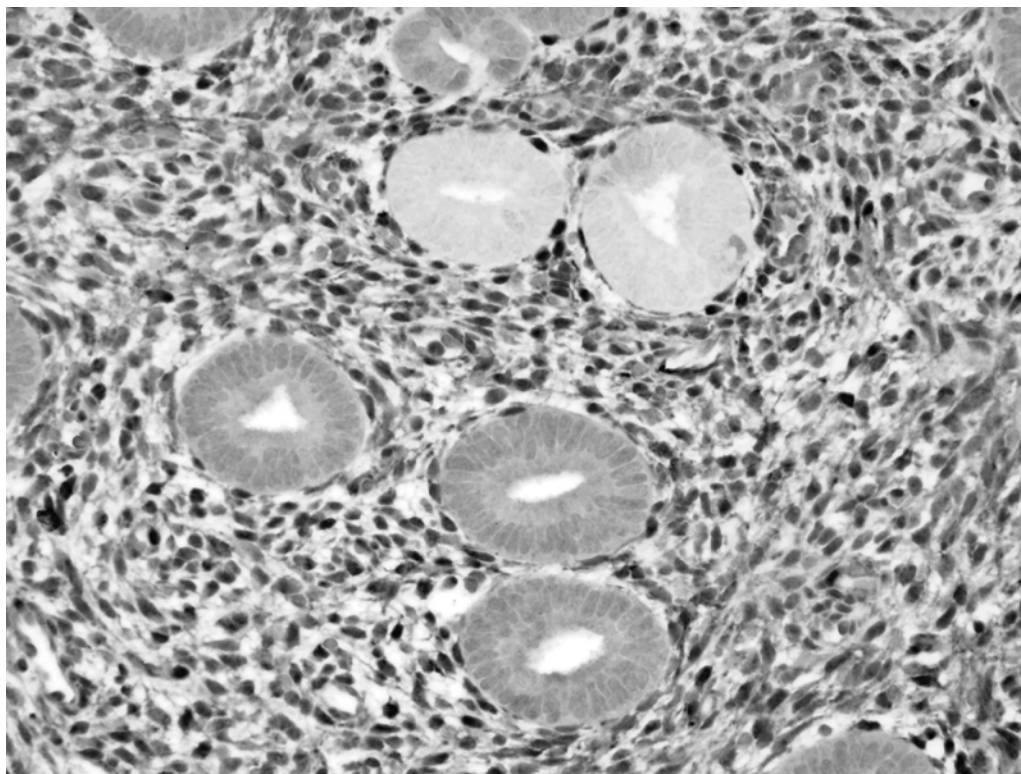

**Fig. 3.** PTEN immunohistochemistry uncovers mutant glands devoid of histological change (latent precancer). Normal proliferative endometrium from a naturally cycling premenopausal woman in which two glands (pale) fail to express PTEN protein, in contrast to stroma and flanking (dark) glands. Microdissection of these nonexpressing glands show somatic genomic mutations in the *PTEN* gene, which are absent in the matched PTEN protein expressing glands. PTEN inactivation is not accompanied by changes in architecture or cytology. PTEN immunohistochemistry with antibody 6h2.1.

however, do not demonstrate MI, so this should not be construed as either a necessary or even predominant, element of endometrial carcinogenesis.

### ***5.3. Emergence of a Histological Lesion***

Progression from a latent precancer state to benign premalignant neoplasm to a malignant neoplasm (carcinoma) is accompanied by alterations in genetics, histology, and clinical behavior. The emergence of discrete histologically altered premalignant lesions corresponds to local clonal expansion of a population of mutated glandular cells (7). This step of transition from a latent to overt phase of disease is of relevance to diagnostic pathologists involved in the clinical management of patients. Other genetic alterations, which are seen in endometrioid endometrial carcinomas include *KRAS* and  $\beta$ -catenin mutation, affecting 10–15% (25–27) and 25–30% (28) of endometrial cancers, respectively. These abnormalities may be invoked during or after the premalignant phase of tumor evolution.

### ***5.4. EIN: A Comprehensive Model of a Precancerous Lesion***

A broad foundation of molecular, histological, and clinical outcome data has established the entity of EIN as the biological precursor for endometrioid endometrial

adenocarcinoma (29). EIN lesions are precancerous lesions with particular biological and histological features that confer a heightened risk for concurrent or future endometrioid endometrial cancer. EIN was defined through an open-ended discovery process, which correlated presence of those molecular features predicted in premalignant disease with histopathological presentation and clinical outcome (30). The result is a robust construct, which has practical application in clinical patient management, and provides a framework to explore those variables and factors that are relevant to the carcinogenesis process.

Because EIN diagnosis applies criteria, which have not been previously considered in the older WHO “hyperplasia” diagnostic schema, there is no direct or absolute concordance between EIN lesions and any specific subset of hyperplasias. For this reason, the EIN diagnostic schema replaces, rather than supplements, the old World Health Organization (WHO) hyperplasia classification. Although, approximately two-third of EIN lesions are culled from the pool of atypical hyperplasias, the balance come from a variety of heterogeneous entities, such as “metaplasias” and “nonatypical hyperplasias.” Once EIN lesions are identified, the balance of “hyperplasias” falls into a variety of specific diagnostic categories corresponding to particular pathogenetic states, including anovulatory endometrium (unopposed estrogen effects), endometrial polyps, and a broad range of unusual presentations of reactive and normal processes.

#### 5.4.1. MOLECULAR FEATURES OF EIN

The latent or subclinical phase of endometrial carcinogenesis is followed by localized emergence of an aggregation of cytologically altered cells arrayed in an architecturally crowded focus known as EIN (Fig. 4) (31,32). Monoclonality of EIN lesions has been demonstrated by the presence of nonrandom X chromosome inactivation among the mutated lesion cells in contrast to the randomly inactivated polyclonal source field (33–35). Other genetic alterations that commonly characterize EIN lesions, such as MI (17,24), *PTEN* mutation (20), and *KRAS* (27) mutations are clonally present among the cells of affected EIN lesions. These genetic changes offset a discrete EIN lesion from its tissue background. This fact indicates that they are the product of somatically acquired mutation rather than inherited genetic changes that would otherwise affect the entire endometrial compartment. The clone, which consists an EIN lesion, may acquire additional mutations or genetic heterogeneity during subsequent clonal expansion, a key element of progression to carcinoma (17). However, not all EIN lesions progress. Some undergo complete involution, whereas others persist for long periods and expand to occupy the entire endometrial compartment as a premalignant lesion.

Adenocarcinoma tissues contain all of the *PTEN*, microsatellite, and X inactivation patterns seen in EIN lesions from the same patient, objective evidence of direct lineage continuity between premalignant and malignant phases of tumor evolution (18). Comparison of the extent and range of genomic damage between premalignant and malignant phases indicates a higher cumulative mutational load in cancers, a feature that must contribute to their differing morphology and behavior. For example, whereas 55% of EIN lesions have demonstrable *PTEN* inactivating events (mutation and/or deletion), the proportion rises to 83% in those cancers which follow an EIN lesion (20). Similarly, for those lesions with MI, the burden of altered microsatellite alleles increases between EIN and carcinoma (17,18). Although, it is convenient to label *PTEN* and microsatellite alterations as “early” events, inactivation of these genetic targets



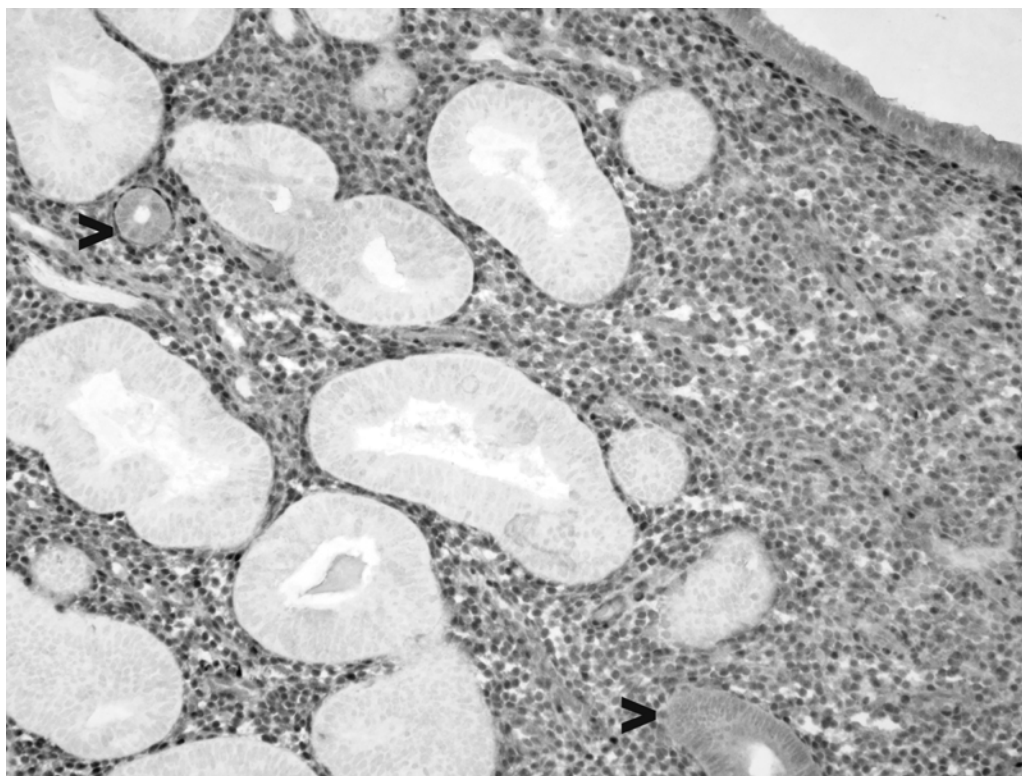

**Fig. 4.** *PTEN* inactivation in an EIN lesion. *PTEN* mutant glands may progress to endometrial intraepithelial neoplasia (EIN), characterized by a focal point of origin and distinctive histological changes. Pale *PTEN* nonexpressing glands within this EIN lesion are larger in diameter and contain a taller epithelium than overrun *PTEN* expressing glands (arrowheads). This EIN lesion was photographed at its outer edge to emphasize its localized topography. Gland area within the lesion perimeter (left half of the image) exceeds that of stroma. *PTEN* immunohistochemistry with antibody 6h2.1.

occurs incrementally and can encompass both premalignant and malignant intervals. Clonal diversification and selection, which continue after malignant transformation, creates genetic heterogeneity within tumors, a feature that may polarize aggressiveness and therapeutic response among component cells of one tumor.

#### 5.4.2. EIN DIAGNOSTIC CRITERIA

Criteria for diagnosis of EIN were developed by objective computerized histomorphometric analysis of a series of individual lesions previously shown by genetic studies to be premalignant (18,30,31). Genetic evidence for premalignant behavior includes a monoclonal growth pattern and genetic alterations conserved in subsequent carcinomas. The histological pattern observed in genetically defined precancers was exactly similar to that documented by independent histomorphometry studies to confer an elevated risk for endometrial carcinoma during clinical follow-up (18). Molecular, diagnostic, and clinical outcome evidence has thus been tightly linked in the newly integrated EIN schema.

EIN can be diagnosed by formal computerized histomorphometric measurement of the D-Score, a quantitative threshold function incorporating architectural (volume percent

**Table 3**  
**EIN Diagnostic Criteria**

<i>EIN criterion</i>	<i>Comments</i>
Architecture	Gland area exceeds stromal area
Cytology	Cytology differs between architecturally crowded focus and background
Size	Maximum linear dimension exceeds 1 mm
Exclude mimics	Benign conditions with overlapping criteria such as basalis, secretory, polyps, repair
Exclude cancer	Carcinoma if mazelike glands, solid areas, or significant cribriforming

All must be met.

stroma, gland outer surface density) and cytological (standard deviation of the shortest nuclear axis) variables (36,37). Histomorphometry has the advantage of an extraordinarily high level of reproducibility and standardization in a commercially available platform (QProdit system manufactured by Leica Microsystems, Cambridge, UK). This provides a durable standard for diagnosis, which has value as a reference and training tool. Morphometric EIN diagnosis for clinical application is in use in some European centers, but practical considerations discourage implementation in the United States. Fortunately, it has been possible to individually extrapolate criteria from the histomorphometric experience into a set of diagnostic rules applicable by pathologists at a standard microscope (Table 3) (38).

Routine EIN diagnosis requires presence of specific topographic, architectural, and cytological features, and exclusion of carcinoma, and benign mimics (Table 3) (29). The clonal origin of EIN lesions begins with localized topography with increasing size over time. Some lesions will be diagnostic only within a single fragment of an endometrial sample, whereas approx 15–20% of lesions will occupy the entire endometrial compartment at time of diagnosis. Lesions smaller than 1mm in maximum dimension do not have a dramatically elevated cancer risk, so this lower size cut off defines the smallest EIN lesion. This measurement is made within a single fragment, by referencing the perimeter as defined by an epicenter of crowded and cytologically altered glands.

The cardinal structural changes of EIN are concurrent changes in both cytology and architecture that offset the lesion from the background endometrial pattern. Crowded glands with a regional surface area more than that of intervening stroma are made up of cells with a different cytology than the background. Significant cytological change must be interpreted relative to the background, as there is no consensus or stereotypical cytological appearance shared by all EIN lesions. Many, but not all, have the nuclear rounding and prominent nucleoli, historically associated with “atypia.” Rather, some EIN lesions have an elongated nuclear cytology, and in other examples the most prominent cytological alteration is cytoplasmic rather than nuclear.

EIN mimics are numerous and must be recognized at a glance. Normal secretory endometrium may have crowded glands, especially in the low functionalis where stromal expansion is minimal. Anovulatory endometria is present as a diffused, nonlocalized, disordered mixture of cysts and proliferative glands. Approximately 15% of EIN lesions occur within endometrial polyps, in which case the polyp must serve as the

counterpoise for diagnosis, not the native functionalis. EIN lesions grow as aggregates of individual glands lined by a single layer epithelium, usually, tubular or with simple branching. Neoplastic epithelium that grows in solid masses, complex folded sheets (with a mazelike interconnected luminal profile), or significantly cribriform lumens should be diagnosed as adenocarcinoma. Interested readers are referred to the educational website [www.endometrium.org](http://www.endometrium.org) for more extensive discussion and illustrations on how to diagnose EIN.

#### 5.4.3. EIN CLINICAL OUTCOME PREDICTION

Patients with EIN lesions have a very high risk for progression to adenocarcinoma, approx 89 times that of women without an EIN lesion. Several clinical outcome studies of women with morphometrically diagnosed EIN (36,39–41) have recently been assembled as a large meta-analysis encompassing 674 endometrial “hyperplasia” patients with clinical follow-up (42). Stratification of the endometrial hyperplasias as EIN vs non-EIN showed an 89-fold increased frequency of endometrial cancer in the EIN group. Depending on the interval between EIN and cancer diagnosis, these cancers might be construed either as concurrent or progression events. Thirty nine percent of patients with an EIN diagnosis were diagnosed with endometrial adenocarcinoma within 1 year, compared with no patients in the non-EIN group. More than 1 year after EIN diagnosis, progression to endometrial adenocarcinoma is 45-fold higher for patients with EIN compared with those without. This is compared with a sevenfold cancer risks for atypical hyperplasia vs nonatypical hyperplasia in the same patient population.

Subjective EIN diagnosis also provides excellent cancer risk prediction (38). A group of 84 women with various endometrial hyperplasias and known clinical outcome included eight cancer occurrences, of which five were in the atypical and three nonatypical hyperplasia groups. When rediagnosed using the EIN schema, all eight cancer occurrences were in women with previous EIN lesions. The number of patients in the high-risk groups was approximately equal for WHO and EIN classifications, including 21 atypical hyperplasias and 25 EINs.

#### 5.5. *Hormonal Risk Modulation in PTEN Mutant Cells*

Estrogens and progestins have a reciprocal effect on endometrioid endometrial cancer risk. Epidemiological studies of endometrial cancer risk factors show a 2–10-fold increased cancer risk in women exposed to estrogens without opposing effects of progestins (6,43–45). The protective effects of progestins are evident in women using combined oral contraceptives, as they have a 0.5–0.7 endometrial cancer risk relative to controls (46,47). Risk modulation occurs through interaction of these systemically administered agents with the target endometrial tissue. Identification of a very high baseline frequency of endometrial mutagenic events, such as PTEN-mutated endometrial cells in up to 43% of otherwise normal premenopausal women (latent precancers, discussed earlier) (22), has renewed the focus on endocrine risk modifiers, rather than mutagenesis rates, as the rate limiting event.

Hormonal exposures known to alter endometrial cancer risk probably do so through their activity as positive or negative selection factors for preexisting mutant endometrial clones. A prerequisite for this hypothesis is that latent endometrial precancers and EIN lesions retain hormonal competence. This is the case, as intact estrogen and progesterone

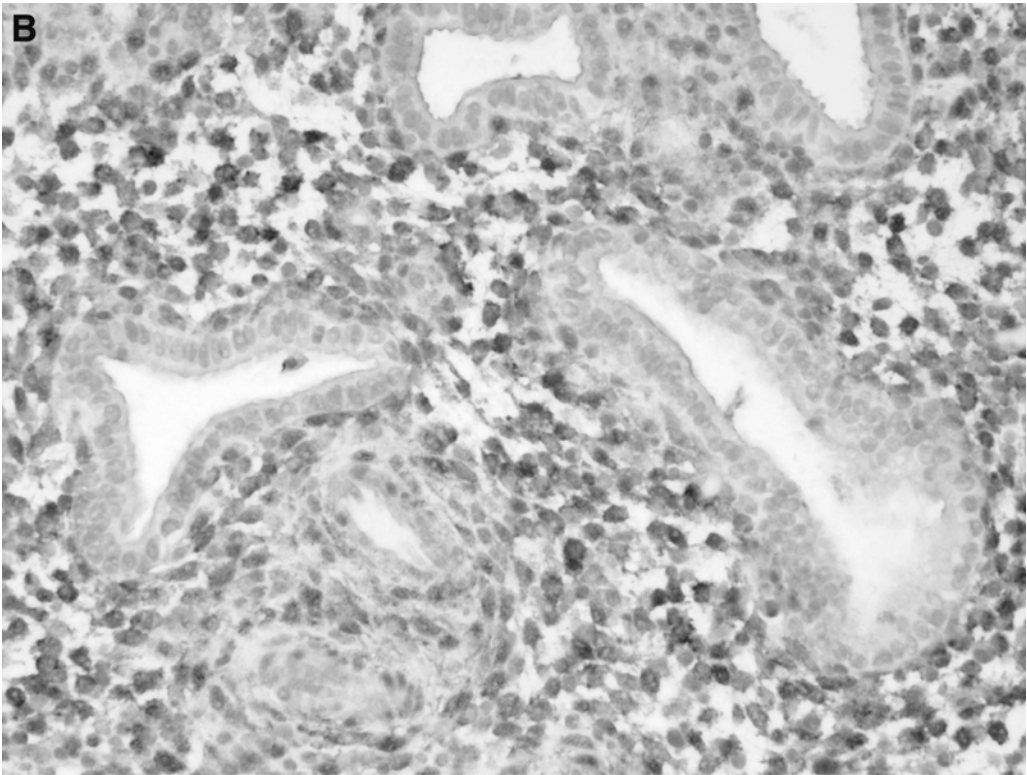
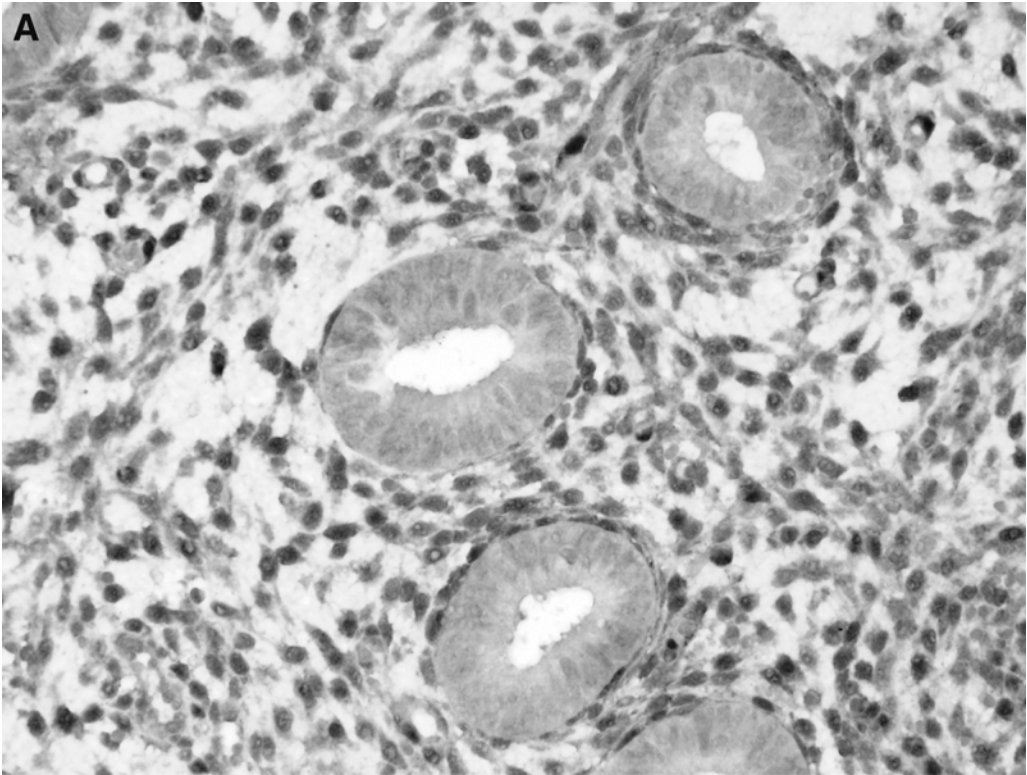

receptors are readily demonstrable in endometrial glands of latent precancers and EIN lesions by immunohistochemistry (22). In order to develop a mechanistic link between hormonal and genetic events during endometrial carcinogenesis, it is necessary to define a point of convergence within affected endometrial cells.

Constitutive *PTEN* expression by genetically intact, normal endometrial cells is highly elevated by estrogens and reduced progesterone during the normal menstrual cycle (Fig. 5) (48). This is evidence that *PTEN*, a tumor suppressor gene known to control the rate of cell division, plays a physiological role in the highly mitotic endometrial glands of an estrogen-rich environment, but not in the mitotically quiescent progesterone-dominant postovulatory phase. Consider the fate of a *PTEN*-mutant clone under varying hormonal conditions. In the presence of unopposed estrogens *PTEN*-mutant endometrial glands will proliferate at advantage relative to normal glands, division of which is checked by PTEN. The mutant clone then expands, thereby increasing the likelihood for additional mutation. In contrast, if the same PTEN mutant clone is admixed with PTEN intact normal glands in a progesterone rich environment, cells of neither genotype will require PTEN function, so behave equivalently and without being selective for the mutant population.

Progestin treatment of a type known to reduce endometrial cancer risk causes preferential involution of *PTEN*-mutant endometrial glands. 83% of latent PTEN-null clones of premenopausal, naturally cycling women with a histologically normal endometrium were present 1 year later (22). There are two implications of this simple observation. First, under hormonally normal circumstances, these cells must be distributed at least in part within the functional reserve of endometrial cells, which regenerate the functionalis each month. Second, long-term persistence of PTEN null clones confirms their availability as a target for transient hormonal exposures. In contrast, in women who receive therapeutic doses of progestins only 10% of PTEN-null clones remain after therapy (a 90% involution rate) (49). Ablation of these clones is accompanied by a reduction in endometrial cancer risk.

## 6. PRECURSORS OF NONENDOMETRIOID ENDOMETRIAL ADENOCARCINOMA

Papillary serous carcinoma is the prototypical example of nonendometrioid endometrial adenocarcinoma, a group that also includes clear cell and carcinosarcoma histotypes (50). Many papillary serous tumors have lost estrogen and progesterone receptors (51), and there are no known hormonal exposures, which increase risk for this variety of carcinoma. Loss of p53 normal function, seen by aberrant immunohistochemical accumulation of the inactivated protein, is a diagnostically useful marker for very scanty or poorly preserved specimens, where a differential diagnosis between surface reactive

---

**Fig. 5.** (*Opposite page*) Physiological changes in PTEN expression during the normal menstrual cycle. Endometrial gland expression of PTEN is the greatest in an estrogen-dominated environment (proliferative endometrium, **Panel A**) and diminishes after several days of progestin exposure (24 day secretory endometrium, **Panel B**). Stromal PTEN expression is high throughout. Physiological requirements for the tumor suppressor function of *PTEN* under varying hormonal conditions is one mechanism whereby the systemic hormonal environment may act as a positive or negative selection factor for *PTEN* mutant glands. PTEN immunohistochemistry with antibody 6h2.1.

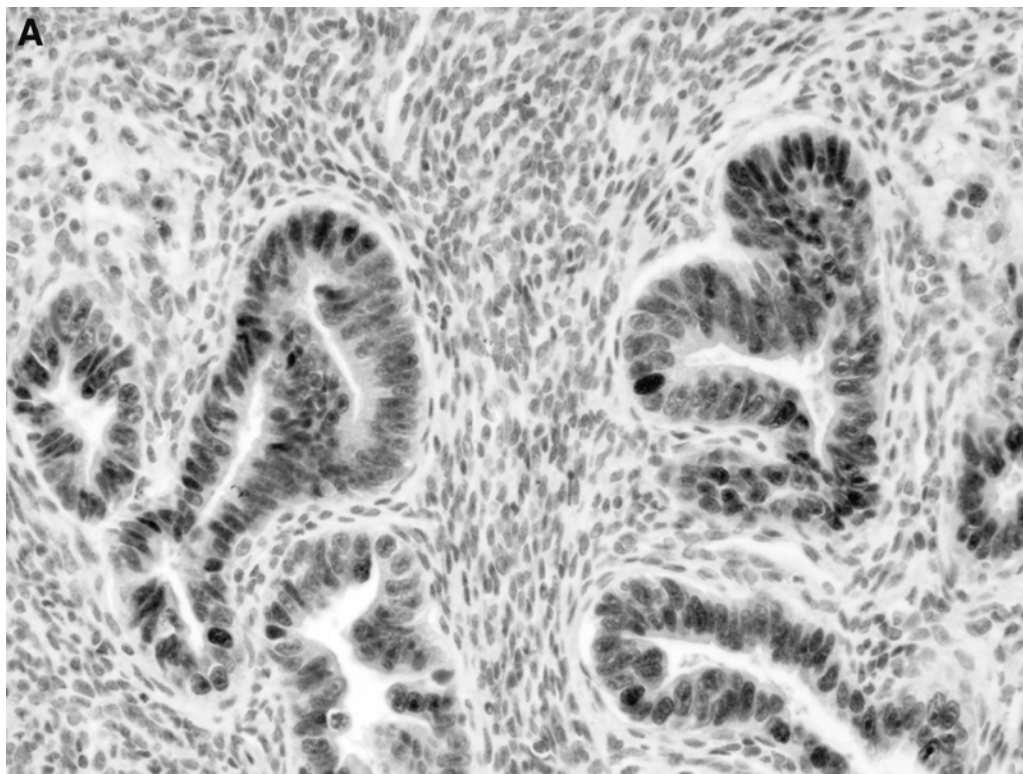

**Fig. 6.** Serous EIC and endometrial glandular dysplasia. *p53* stain of serous EIC (**Panel B**) and endometrial glandular dysplasia (**Panel A**) show a gradation of cytological atypia and abnormal *p53* staining between these entities. Both are *in situ* lesions, which frequently coexist in women with invasive papillary serous carcinoma. Endometrial glandular dysplasia example is kindly supplied by Wenxin Zheng, Yale University, New Haven, CT.

change and surface distributed carcinoma is difficult to resolve on morphological architectural grounds alone (52). In these instances, extreme cytological atypia is a key element of the diagnosis.

There is much less information about the precursors of type II cancers when compared with the abundant data for type I endometrial cancers. One reason is that papillary serous cancers are much less frequent than their endometrioid counterparts, making it difficult to assemble large series for study. Additionally a rapid tempo of papillary serous carcinoma emergence from an apparently normal state presents a narrow temporal window for clinical detection of early disease. Serous Endometrial intraepithelial carcinoma (EIC) and endometrial glandular dysplasia (EGD) are the best candidates for preinvasive malignant and premalignant papillary serous disease, respectively.

### ***6.1. Serous EIC: An Immediate Precursor to Invasion***

Serous endometrial intraepithelial carcinoma (serous EIC [29,53]) is a noninvasive form of papillary serous adenocarcinoma (54) (Fig. 6, Panel B). Serous EIC, seen in almost 90% of uteri with papillary serous carcinoma (53), is made up of cells identical to invasive papillary serous carcinoma in their cytology and in the presence of p53 mutation. It's most common presentation is thus a pattern of extension from the

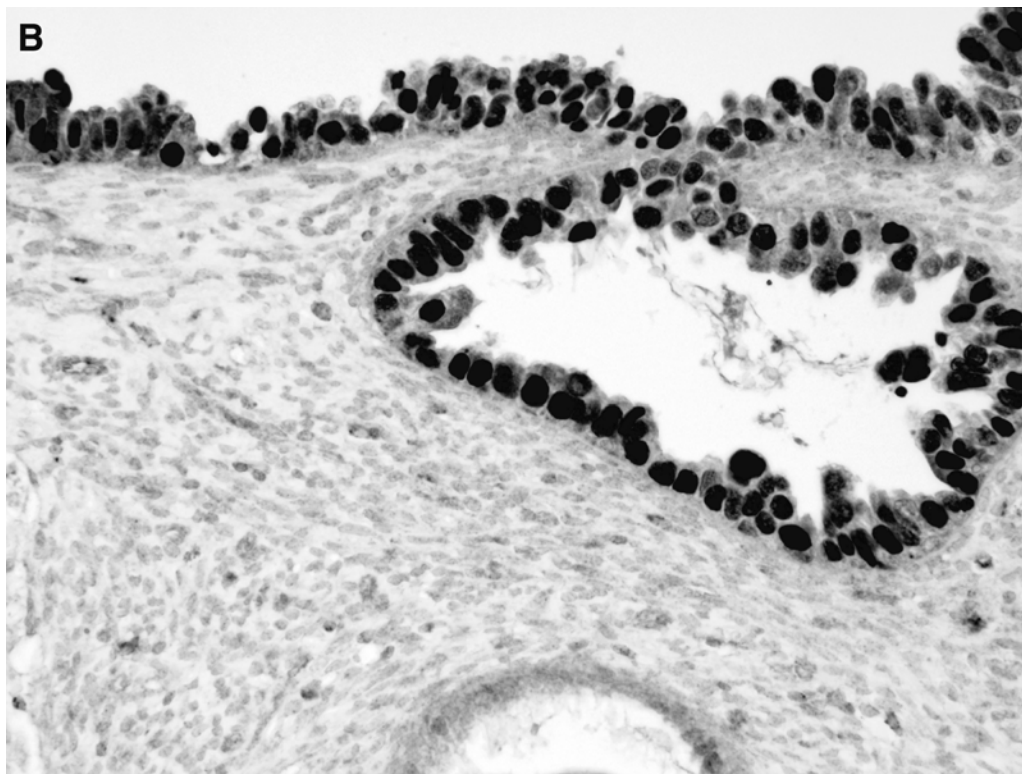

**Fig. 6.** (Continued)

coexisting invasive tumor. Occasionally, serous EIC is seen as the initial diagnostic manifestation of a noninvasive papillary serous adenocarcinoma (52). Isolated EIC is a lesion with intrinsic malignant behavior, as it has the capacity for peritoneal metastasis to abdominal sites (55). In this regard it cannot be considered a premalignant lesion, but rather an immediate precursor of the invasive form of disease.

### ***6.2. Uterine Glandular Dysplasia: A Potential Precancerous Serous Lesion***

Careful scrutiny of endometria with (invasive or noninvasive) papillary serous carcinoma has disclosed a lesion with histology and genotype intermediate between normal glands and serous carcinoma. EGD lacks the wild cytological atypia of serous EIC, has only patchy or moderate abnormalities of p53 staining, and a mitotic activity somewhat less than associated carcinomas (56) (Fig. 6, Panel A). Frequent occurrence, in up to 53% of uteri with serous carcinomas, is as expected for a precursor lesion. EGD tends to be multifocal, involving luminal surface epithelium, sometimes within endometrial polyps. Molecular analysis of allelic losses within individual patients has shown progressive incremental deletions in the spectrum from normal to EGD to serous carcinoma, thereby confirming a stepwise relationship among these phases of disease (57). The frequency of EGD occurrence outside a cancer context is unknown, and a histological phenotype easily confused with reactive changes complicates its reliable identification. Clinical outcome studies of patients with isolated genotype-confirmed EGD is needed to define the natural history of this lesion and its place in patient management.

## 7. FUTURE IMPLICATIONS

The endometrial experience highlights the problems and benefits of a disease model increasingly dominated by a molecular perspective. Interacting disease mechanisms may intersect in hormonal selection of *PTEN*-mutant endometrial clones. Observed clinical outcomes reflect the balance of all of these factors as played out against the backdrop of a single patient. Thus, molecular epidemiology should not be construed as a descriptive science of those molecular defects present within a population, but rather the complex dynamics of selection between nongenetic, systemic, and environmental factors, and acquired somatic genetic defects, which arise at a surprisingly high rate among normal individuals. The resulting hybrid model incorporating multiple disciplines presents significant challenges for the individual contributing fields. Will molecular markers supplant diagnostic histopathology in clinical decision making? How should the value of precise and objective molecular analysis be weighed against the population variation and individual contexts in which they occur? Responsible clinical care will be the ultimate arbiter of these unresolved debates, and the best measure of future success.

An intriguing aspect of this disease is the latent phase—invisible to routine histopathological examination, but now detectable with specialized biomarkers. An extraordinarily high frequency of acquired silent mutations in histologically “normal” tissues, challenges the concept that initiation of carcinogenesis is an abnormal event, or even limited by mutational rates. It is very likely that those nongenetic events known to alter cancer risk act through their effect on such latent precancers. Reduction of risk, such as achieved by progestin exposure, leads to involution of latent precancers. Increase of cancer risk, such as caused by unopposed estrogen, leads to histological progression from latent to clinically diagnosable EIN disease. A rational conclusion is that many examples of endometrial cancer might be prevented by those interventions, which selectively destroy latent precancer cells. Correspondingly, the efficacy of such interventions might be measured in short order by direct observation of changes in the latent precancer prevalence before and after therapy. These hypotheses are easily formulated, can be tested experimentally in modestly sized populations during short periods of time, and could lead to bonafide cancer preventative strategies for this common disease.

## REFERENCES

1. Hendrickson M, Martinez A, Ross J, Kempson R, Eifel P. Uterine papillary serous carcinoma, a highly malignant form of endometrial adenocarcinoma. *Am J Surg Pathol* 1982; 6: 93–108.
2. Bokhman J. Two pathogenetic types of endometrial carcinoma. *Gynecol Oncol* 1983; 15: 10–17.
3. Deligdisch L, Holinka C. Endometrial carcinoma: two diseases? *Cancer Detect Prev* 1987; 10: 237–246.
4. Sherman ME, Bur ME, Kurman RJ. p53 in endometrial cancer and its putative precursors: evidence for diverse pathways of tumorigenesis. *Hum Pathol* 1995; 26: 1268–1274.
5. Sherman ME. Theories of endometrial carcinogenesis: a multidisciplinary approach. *Mod Pathol* 2000; 13(3): 295–308.
6. Parazzini F, La Vecchia C, Bocciolone L, Franceschi S. The epidemiology of endometrial cancer. *Gynecol Oncol* 1991; 41: 1–16.
7. Mutter GL. Diagnosis of premalignant endometrial disease. *J Clin Pathol* 2002; 55(5): 326–331.
8. Mutter GL. PTEN, a protean tumor suppressor. *Am J Pathol* 2001; 158: 1895–1898.
9. Esteller M, Levine R, Baylin SB, Ellenson LH, Herman JG. MLH1 promoter hypermethylation is associated with the microsatellite instability phenotype in sporadic endometrial carcinomas. *Oncogene* 1998; 17: 2413–2417.
10. Faquin WC, Fitzgerald JT, Lin MC, Boynton KA, Muto MG, Mutter GL. Sporadic microsatellite instability is specific to neoplastic and preneoplastic endometrial tissues. *Am J Clin Pathol* 2000; 113(4): 576–582.



11. Basil JB, Goodfellow PJ, Rader JS, Mutch DG, Herzog TJ. Clinical significance of microsatellite instability in endometrial carcinoma. *Cancer* 2000; 89(8): 1758–1764.
12. Aaltonen LA, Peltomaki P, Mecklin JP, et al. Replication errors in benign and malignant tumors from hereditary nonpolyposis colorectal cancer patients. *Cancer Res* 1994; 54: 1645–1648.
13. Lynch HT, Casey MJ, Shaw TG, Lynch JF. Hereditary Factors in Gynecologic Cancer. *Oncologist* 1998; 3(5): 319–338.
14. Hertig A, Sommers S. Genesis of endometrial carcinoma. I. Study of prior biopsies. *Cancer* 1949; 2: 946–956.
15. Scully RE, Bonfiglio TA, Kurman RJ, Silverberg SG, Wilkinson EJ. Uterine corpus. *Histological Typing of Female Genital Tract Tumors*. New York, Springer-Verlag, 1994, pp. 13–31.
16. Kurman R, Kaminski P, Norris H. The behavior of endometrial hyperplasia: a long term study of “untreated” hyperplasia in 170 patients. *Cancer* 1985; 56: 403–412.
17. Mutter GL, Boynton KA, Faquin WC, Ruiz RE, Jovanovic AS. Allelotype mapping of unstable microsatellites establishes direct lineage continuity between endometrial precancers and cancer. *Cancer Res* 1996; 56: 4483–4486.
18. Mutter GL, Baak JPA, Crum CP, Richart RM, Ferenczy A, Faquin WC. Endometrial precancer diagnosis by histopathology, clonal analysis, and computerized morphometry. *J Pathol* 2000; 190: 462–469.
19. Risinger JI, Hayes AK, Berchuck A, Barrett JC. PTEN/MMAC1 mutations in endometrial cancers. *Cancer Res* 1997; 57(21): 4736–4738.
20. Mutter GL, Lin MC, Fitzgerald JT, et al. Altered PTEN expression as a diagnostic marker for the earliest endometrial precancers. *J Natl Cancer Inst* 2000; 92: 924–930.
21. Stambolic V, Tsao MS, Macpherson D, Suzuki A, Chapman WB, Mak TW. High incidence of breast and endometrial neoplasia resembling human Cowden syndrome in pten+/- mice. *Cancer Res* 2000; 60(13): 3605–3611.
22. Mutter GL, Ince TA, Baak JPA, Kust G, Zhou X, Eng C. Molecular identification of latent precancers in histologically normal endometrium. *Cancer Res* 2001; 61: 4311–4314.
23. Goodfellow PJ, Buttin BM, Herzog TJ, et al. Prevalence of defective DNA mismatch repair and MSH6 mutation in an unselected series of endometrial cancers. *Proc Natl Acad Sci USA* 2003; 100(10): 5908–5913.
24. Esteller M, Catusas L, Matias-Guiu X, et al. hMLH1 Promoter Hypermethylation Is an Early Event in Human Endometrial Tumorigenesis. *Am J Pathol* 1999; 155(5): 1767–1772.
25. Enomoto T, Inoue M, Perantoni A, et al. K-ras activation in premalignant and malignant epithelial lesions of the human uterus. *Cancer Res* 1991; 51: 5304–5314.
26. Duggan BD, Felix JC, Muderspach LI, Tsao J-L, Shibata DK. Early mutational activation of the c-Ki-ras oncogene in endometrial carcinoma. *Cancer Res* 1994; 54: 1604–1607.
27. Mutter GL, Wada H, Faquin W, Enomoto T. K-ras mutations appear in the premalignant phase of both microsatellite stable and unstable endometrial carcinogenesis. *Mol Pathol* 1999; 52: 257–262.
28. Matias-Guiu X, Catusas L, Bussaglia E, et al. Molecular pathology of endometrial hyperplasia and carcinoma. *Hum Pathol* 2001; 32(6): 569–577.
29. Silverberg SG, Mutter GL, Kurman RJ, Kubik-Huch RA, Nogales F, Tavassoli FA. Tumors of the uterine corpus: epithelial tumors and related lesions. in: *WHO Classification of Tumors: Pathology and Genetics of Tumors of the Breast and Female Genital Organs* (Tavassoli FA, Stratton MR, eds.), IARC Press, Lyon, France, 2003, pp. 221–232.
30. Mutter GL, The Endometrial Collaborative Group. Endometrial intraepithelial neoplasia (EIN): Will it bring order to chaos? *Gynecol Oncol* 2000; 76: 287–290.
31. Mutter GL. Histopathology of genetically defined endometrial precancers. *Int J Gynecol Pathol* 2000; 19: 301–309.
32. Mutter GL, Ince TA. Molecular Pathogenesis of Endometrial Cancer. in: *Uterine Cancer: American Cancer Society Atlas of Clinical Oncology* (Fuller A, Seiden MV, Young R, eds.), Hamilton, Ontario, Canada, B.C.Decker, 2003, pp. 10–21.
33. Mutter GL, Chaponot M, Fletcher J. A PCR assay for non-random X chromosome inactivation identifies monoclonal endometrial cancers and precancers. *Am J Pathol* 1995; 146: 501–508.
34. Mutter GL, Boynton KA. X chromosome inactivation in the normal female genital tract: Implications for identification of neoplasia. *Cancer Res* 1995; 55: 5080–5084.
35. Jovanovic AS, Boynton KA, Mutter GL. Uteri of women with endometrial carcinoma contain a histopathologic spectrum of monoclonal putative precancers, some with microsatellite instability. *Cancer Res* 1996; 56: 1917–1921.

36. Baak JPA, Nauta J, Wisse-Brekelmans E, Bezemer P. Architectural and nuclear morphometrical features together are more important prognosticators in endometrial hyperplasias than nuclear morphometrical features alone. *J Pathol* 1988; 154: 335–341.
37. Baak JPA. *Manual of Quantitative Pathology in Cancer Diagnosis and Prognosis*. New York: Springer-Verlag, 1991 p. 332–338.
38. Hecht JL, Ince TA, Baak JP, Baker HE, Ogden MW, Mutter GL. Prediction of endometrial carcinoma by subjective endometrial intraepithelial neoplasia diagnosis. *Mod Pathol* 2005; 18: 324–330.
39. Dunton C, Baak J, Palazzo J, van Diest P, McHugh M, Widra E. Use of computerized morphometric analyses of endometrial hyperplasias in the prediction of coexistent cancer. *Am J Obstet Gynecol* 1996; 174: 1518–1521.
40. Orbo A, Baak JP, Kleivan I, et al. Computerised morphometrical analysis in endometrial hyperplasia for the prediction of cancer development. A long-term retrospective study from northern Norway. *J Clin Pathol* 2000; 53(9): 697–703.
41. Baak JP, Orbo A, van Diest PJ, et al. Prospective multicenter evaluation of the morphometric D-score for prediction of the outcome of endometrial hyperplasias. *Am J Surg Pathol* 2001; 25(7): 930–935.
42. Baak JPA, Mutter GL, Robboy S, et al. In endometrial hyperplasias, the molecular-genetics and morphometry-based EIN classification more accurately predicts cancer-progression than the WHO94. *Cancer* 2005; 103(11).
43. Potischman N, Hoover R, Briton L, et al. Case control study of exogenous steroid hormones and endometrial cancer. *J Natl Cancer Inst* 1996; 88: 1127–1135.
44. Writing Group for the PEPI Trial. Effects of hormone replacement therapy on endometrial histology in postmenopausal women. The Postmenopausal Estrogen/Progestin Interventions (PEPI) Trial. *JAMA* 1996; 275: 370–375.
45. Zeleniuch-Jacquotte A, Akhmedkhanov A, Kato I, et al. Postmenopausal endogenous oestrogens and risk of endometrial cancer: results of a prospective study. *Br J Cancer* 2001; 84(7): 975–981.
46. Grimes DA, Economy KE. Primary prevention of gynecologic cancers. *Am J Obstet Gynecol* 1995; 172: 227–235.
47. Weiderpass E, Adami HO, Baron JA, Magnusson C, Lindgren A, Persson I. Use of oral contraceptives and endometrial cancer risk (Sweden). *Cancer Causes Control* 1999; 10(4): 277–284.
48. Mutter GL, Lin MC, Fitzgerald JT, Kum JB, Ziebold U, Eng C. Changes in endometrial PTEN expression throughout the human menstrual cycle. *J Clin Endocrinol Metab* 2000; 85: 2334–2338.
49. Zheng W, Baker HE, Mutter GL. Involution of PTEN-Null Endometrial Glands with Progestin Therapy. *Gynecol Oncol* 2004; 92: 1008–1013.
50. Sherman ME, Sturgeon S, Brinton L, Kurman RJ. Endometrial cancer chemoprevention: implications of diverse pathways of carcinogenesis. *J Cell Biochem* 1995; 59(Suppl 23): 160–164.
51. Kounelis S, Kapranos N, Kouri E, Coppola D, Papadaki H, Jones MW. Immunohistochemical profile of endometrial adenocarcinoma: a study of 61 cases and review of the literature. *Mod Pathol* 2000; 13(4): 379–388.
52. Zheng W, Khurana R, Farahmand S, Wang Y, Zhang ZF, Felix JC. p53 immunostaining as a significant adjunct diagnostic method for uterine surface carcinoma: precursor of uterine papillary serous carcinoma. *Am J Surg Pathol* 1998; 22(12): 1463–1473.
53. Sherman ME, Bitterman P, Rosenshein NB, Delgado G, Kurman RJ. Uterine serous carcinoma. A morphologically diverse neoplasm with unifying clinicopathologic features. *Am J Surg Pathol* 1992; 16(6): 600–610.
54. Ambros RA, Sherman ME, Zahn CM, Bitterman P, Kurman RJ. Endometrial intraepithelial carcinoma: A distinctive lesion specifically associated with tumors displaying serous differentiation. *Hum Pathol* 1995; 26: 1260–1267.
55. Wheeler DT, Bell KA, Kurman RJ, Sherman ME. Minimal uterine serous carcinoma: diagnosis and clinicopathologic correlation. *Am J Surg Pathol* 2000; 24(6): 797–806.
56. Zheng W, Liang SX, Yu H, Rutherford T, Chambers SK, Schwartz PE. Endometrial glandular dysplasia: a newly defined precursor lesion of uterine papillary serous carcinoma. Part I: morphologic features. *Int J Surg Pathol* 2004; 12(3): 207–223.
57. Liang SX, Chambers SK, Cheng L, Zhang S, Zhou Y, Zheng W. Endometrial glandular dysplasia: a putative precursor lesion of uterine papillary serous carcinoma. Part II: molecular features. *Int J Surg Pathol* 2004; 12(4): 319–331.
58. Berchuck A, Boyd J. Molecular basis of endometrial cancer. *Cancer* 1995; 76(Suppl): 2034–2040.

# 6

---

## Endometrial Carcinoma—Molecular Genetic Aspects

---

*Lora Hedrick Ellenson, MD*

### CONTENTS

INTRODUCTION
TYPE I AND TYPE II ENDOMETRIAL CARCINOMA
MOLECULAR GENETICS OF UNCOMMON ENDOMETRIAL CARCINOMA
RELATIONSHIP OF HORMONES AND MOLECULAR GENETIC ALTERATIONS
MOUSE MODEL OF ENDOMETRIOID CARCINOMA
CONCLUSION
REFERENCES

---

### 1. INTRODUCTION

The molecular genetic characterization of endometrial carcinoma has clearly contributed to the understanding of this common disease. However, the interpretation of such studies has relied on careful clinicopathological classification of the tumors. Many of the early molecular genetic studies of endometrial carcinoma were hampered by the lack of careful tumor classification. Much of the problem was related to the fact that the classification scheme, described in the previous chapter, initially described in 1983 has only recently gained widespread acceptance. Consequently, and understandably, many of the early studies did not clearly state the type (or types) of endometrial carcinomas that were included. Additionally, many studies that classified tumors lacked significant numbers to allow the results from the different tumor types to be assessed independently, partly because of the fact that type II tumors are relatively uncommon. However, recent molecular genetic studies have supported the dualistic categorization of endometrial carcinoma and have resulted in important insights into the pathogenesis of the two major types of carcinoma (Fig. 1). In addition, such studies are beginning to elucidate the molecular underpinnings of some of the more uncommon types of endometrial carcinoma that are not so easily classified in the dualistic model of endometrial carcinoma. This chapter will focus primarily on the molecular studies that have supported the dualistic model and a short discussion on one of the more uncommon forms of endometrial carcinoma. In addition, the relationship between genetics and

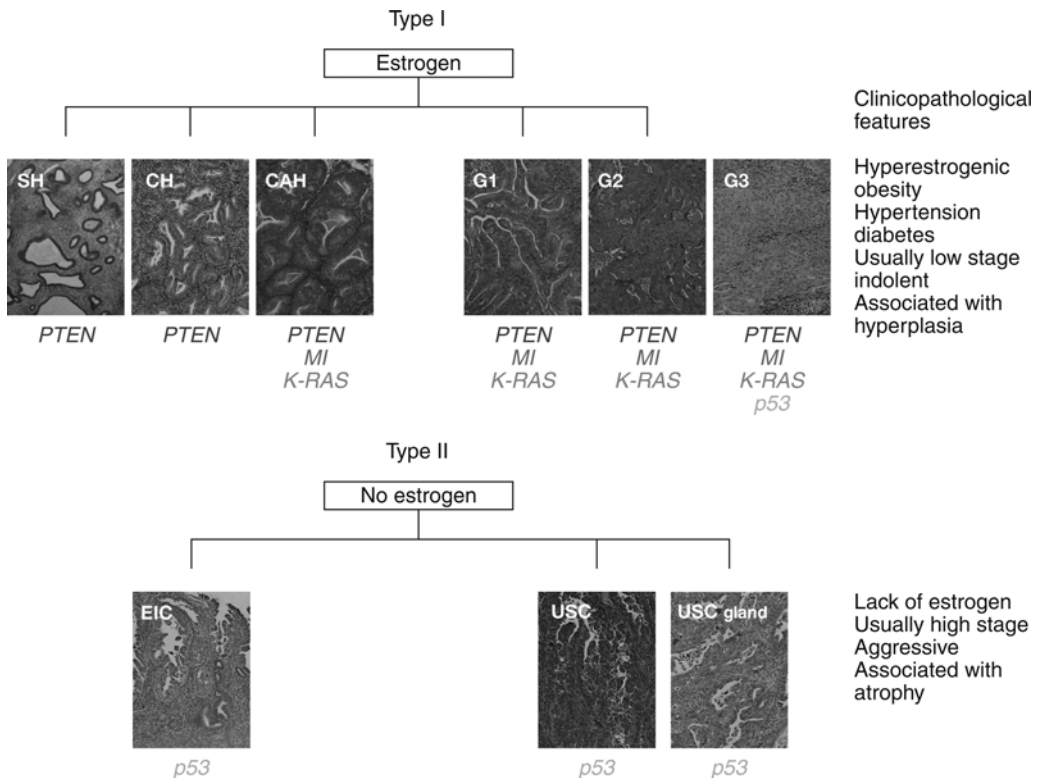

**Fig. 1.** Histological and molecular characteristics of endometrial lesions. The precursor lesions are shown on the left and the invasive tumors on the right. The common molecular genetic alterations found in each morphological entity are shown directly under each photomicrograph. SH, simple hyperplasia; CH, complex hyperplasia; CAH, complex atypical hyperplasia; G1, Grade 1 endometrioid carcinoma; G2, Grade 2 endometrioid carcinoma; G3, Grade 3 endometrioid carcinoma; EIC, endometrial intraepithelial carcinoma; USC, papillary form of serous carcinoma; USC glandular, glandular form of serous carcinoma. From ref. 24.

hormones in the context of endometrial carcinoma will be briefly discussed followed by a short introduction of a genetic mouse model of endometrial carcinoma.

## 2. TYPE I AND TYPE II ENDOMETRIAL CARCINOMA

### 2.1. Endometrioid (Type I) Carcinoma

Endometrioid carcinoma, generally categorized as type I carcinoma, is the most common type of endometrial carcinoma, accounting for approx 80–85% of all cases. Consequently, it has been more extensively studied at the molecular level than the other histological types. A wide variety of cancer-related genes have been analyzed in this tumor type, but only the most commonly altered genes will be discussed in this chapter.

The tumor suppressor gene, *PTEN* is mutated in a wide variety of human tumors and is the most frequently altered gene in endometrioid carcinoma. In fact, endometrioid carcinoma has the highest frequency of intragenic *PTEN* mutations compared with any

other single tumor type. *PTEN* is located on chromosome 10q23.3, a region of the genome that undergoes loss of heterozygosity in approx 20–30% of endometrioid carcinomas and 30–80% of tumors having intragenic mutation (1). In addition, mutations have been detected in approx 20% of hyperplastic lesions, both with and without atypia, suggesting that mutations in *PTEN* occur relatively early in the pathogenesis of endometrioid carcinoma (2,3). This is in contrast to other tumor types (e.g., prostate cancer, melanoma, and gliomas), in which *PTEN* is believed to be inactivated later in their development. Initially, based on sequence homology, it was believed that *PTEN* encoded a dual specificity protein phosphatase. It was later shown that *in vitro* it had lipid phosphatase activity (4). Presently, its most well-documented substrate is the lipid molecule phosphatidylinositol 3,4,5-triphosphate. This lipid molecule is an important second messenger that regulates the phosphorylation of a protein called AKT (also known as protein kinase-B). The downstream targets of phosphorylated AKT include a number of molecules that directly affect cell-cycle regulation (e.g., p21WAF1/CIP1, p27KIP1) and apoptosis (e.g., BAD, MDM2, FKHR). Thus, loss of *PTEN* function results in the ability of cells to both proliferate and escape cellular senescence.

In *in vitro* studies the introduction of *PTEN* into tumor cells that lacks its expression results in either cell-cycle arrest or apoptosis depending on the cell type and the amount of exogenously expressed PTEN. In endometrial carcinoma cell lines both apoptosis and cell-cycle arrest have been induced by the introduction of wild-type *PTEN* into cells with altered *PTEN*. In the study that demonstrated apoptosis, PTEN was introduced using adenovirus-mediated gene transfer, which resulted in marked overexpression of the protein (5). In the study, in which *PTEN* induced a G<sub>1</sub> cell-cycle arrest, a retroviral approach was used, which generated more physiological levels of PTEN expression (6). In cell lines with altered *PTEN*, there were increased levels of phosphorylated AKT that decreased with introduction of wild-type *PTEN* and the growth of cells containing wild-type *PTEN* was unaffected by exogenous *PTEN* expression. In the latter studies, growth arrest required a functional phosphatase domain. Total levels of CIP/KIP and INK4 family members, the known inhibitory regulators of the G<sub>1</sub> phase of the cell cycle, were unchanged. However, PTEN induced a specific reduction of cyclin D3 levels, and an associated increase in the amount of the inhibitor p27<sup>KIP1</sup> complexed with CDK2 (6). These studies suggest that in the endometrium loss of PTEN might contribute to both loss of cell-cycle regulation and avoidance of cell death. In other tumor systems PTEN has resulted in increased levels of p27<sup>KIP1</sup>. The significance of this finding in the endometrial cancer cell lines is unclear as immunohistochemical studies have suggested that endometrial carcinomas often show an increase in cyclin D1 expression (7).

There is a wide spectrum of mutations (missense, nonsense, and frameshift) of *PTEN* in endometrioid carcinoma, which primarily occur in exons 3–5, 7, and 8 targeting not only the phosphatase domain, but also regions that control protein stability, phosphatase activity, and localization (1,8). Many of the mutations result in decreased expression of PTEN documented by both Western blot analysis and immunohistochemistry. Furthermore, one study has found loss of PTEN expression in clusters of endometrial glands that appear morphologically benign, suggesting that *PTEN* alteration may precede the development of detectable light microscopic lesions (9). In addition, some data have suggested that epigenetic mechanisms (e.g., promoter hypermethylation) and subcellular localization can affect PTEN function in the

absence of intragenic mutations. However, neither the *in vitro* studies nor the mutational analysis have elucidated the mechanism by which loss of *PTEN* contributes to the early development of endometrial carcinoma. Interestingly, as discussed later, intragenic mutations in *PTEN* are associated with microsatellite instability (MSI), another common early molecular alteration found in endometrioid carcinomas (1,10). Although, the association is believed to be important, the mechanism(s) underlying it and its consequences remain unclear.

MSI is defined as alterations in the length of short, repetitive DNA sequences. The instability of the repeats is a direct consequence of the lack of intact DNA mismatch repair, an essential system for correcting DNA sequence errors created during replication. In endometrioid carcinoma and other tumors, the DNA mismatch repair system is disabled either through intragenic mutation of one of the DNA mismatch repair genes or more commonly through promoter hypermethylation of the *MLH1* gene (11,12). The absence of DNA mismatch repair results in an increase in the rate of mutation in other cancer-causing genes, thus accelerating tumorigenesis. MSI is detected in approx 20% of sporadic endometrial cancers and can be found in complex atypical hyperplasias that are associated with cancers that demonstrate instability (2). However, it has not been found in lesser degrees of hyperplasia, although methylation of the hMLH1 promoter has been detected in hyperplasia without atypia (13).

MSI is also found in endometrial carcinomas arising in patients affected by hereditary nonpolyposis colorectal carcinoma, a family cancer syndrome, in which endometrial carcinoma is the most common noncolorectal malignancy. Although, it remains unclear exactly when in the development of endometrial neoplasia the DNA mismatch repair system becomes inactivated, the presence of MSI in hyperplastic lesions and the high incidence of endometrial carcinoma in Hereditary nonpolyposis colorectal carcinoma families suggest that it may occur early in its pathogenesis. Additional studies are necessary to address the exact mechanisms and timing of DNA mismatch repair inactivation in the development of endometrioid carcinoma. Answers to this question are not only of biological interest, but may also have important clinical ramifications.

The *TP53* tumor suppressor gene has received considerable attention in endometrial cancer. Mutations in *TP53* are found in approx 10–20% of all endometrioid carcinomas, the majority occurring in high-grade tumors. Approximately 50% of Grade 3 tumors and rare Grade 2 tumors, contain *TP53* mutations, but they have not been identified in Grade 1 tumors or endometrial hyperplasia (14). Furthermore, a number of studies have shown that both p53 overexpression and mutation are associated with a poor prognosis (15). It is of interest to note that Bohkman classified Grade 3 endometrioid carcinomas as type II tumors in the original study. Molecular data now exist, which suggest that most Grade 2 and some Grade 3 tumors have molecular profiles similar to Grade 1 tumors (e.g., *PTEN* and *K-ras* mutations, and MSI) (14).

In addition, a number of oncogenes (e.g., *c-myc*, *HER-2/neu*, *bcl-2*, and *c-fms*) have been studied in endometrial carcinomas, but only a few are altered in a significant number of cases. One of the most commonly altered is the *KRAS* protooncogene. *KRAS* encodes a guanine nucleotide binding protein of 21 kDa, which has a central role in the regulation of cell growth and differentiation by transducing signals from activated transmembrane receptors. Mutations in *KRAS* result in constitutive activity even in the absence of an activated receptor and, in several studies have been identified

consistently in 10–30% of endometrial cancers (14). The mutations have been found in all grades of endometrioid carcinoma and have been reported in complex atypical hyperplasia, suggesting a relatively early role for *KRAS* mutations in this tumor type. Most recently, mutations in the *CTNNB1* gene have been found in approx 15–20% of endometrioid carcinomas with an accumulation of the protein found in 38% of cases (16,17). This suggests a role for the *Wnt* signal transduction pathway, a pathway commonly altered in colorectal carcinoma. Interestingly, aberrations have recently been described in this pathway in endometrioid tumors of the ovary. Additional studies will be needed to determine the significance of this pathway in endometrioid carcinomas of the uterus.

## 2.2. Serous (Type II) Carcinoma

Serous carcinoma has been studied less intensively than endometrioid carcinoma owing largely to its relative infrequency, accounting for only 10–15% of all endometrial carcinomas. Further complicating the issue is that many studies in the past did not recognize it as a distinct entity. Although a number of cancer-causing genes have been studied, only the *TP53* tumor suppressor gene is altered in a significant number of cases. Some studies have detected *TP53* mutations in almost 90% of cases making it one of the small number of adult solid tumors with such a high frequency of mutation in a single gene (18). Furthermore, approx 75% of endometrial intraepithelial carcinomas, the putative precursor of serous carcinoma, have mutations in *TP53* implicating a role for its inactivation early in the development of this aggressive tumor type. This is in contrast to endometrioid carcinoma in which *TP53* mutations are relatively uncommon and are largely confined to Grade 3 tumors. Thus, it is possible that the mutation of *TP53* early in the pathogenesis of serous carcinoma is an important factor in determining its aggressive behavior. In addition, the fact that *TP53* mutations occur most commonly in Grade 3 endometrioid and serous carcinomas may provide an explanation for overexpression and mutation of *TP53* as an independent indicator of poor prognosis.

In contrast to endometrioid carcinoma, mutations in *KRAS* and *PTEN* appear to be highly uncommon in serous carcinoma (14). Additionally, MSI has not been described. Studies have suggested that there is amplification and overexpression of *c-myc* and *Her-2/neu*; however, it is not clear from the literature what percent of serous carcinomas demonstrate these alterations.

As in other tumor systems, the molecular studies of endometrial cancer support the concept that epithelial-derived tumors develop from preinvasive lesions that accrue a constellation of genetic alterations, providing the cell with the attributes necessary for unregulated growth (Fig. 1). In endometrioid carcinoma, *PTEN* alterations appear to be central to the initiation of proliferative lesions that then acquire mutations in other cancer-causing genes (e.g., DNA mismatch repair genes, *KRAS*, *TP53*) in the progression to malignancy. Conversely, *TP53* mutations appear to be critical in the conversion of relatively quiescent, atrophic endometrium into an intraepithelial form of serous carcinoma, which then sets the stage for the accumulation of alterations in as yet unidentified cancer-causing genes. Finally, although the dualistic model is valid, it may not adequately encompass the more uncommon types of endometrial carcinoma, including clear cell carcinoma, which will be briefly discussed next.

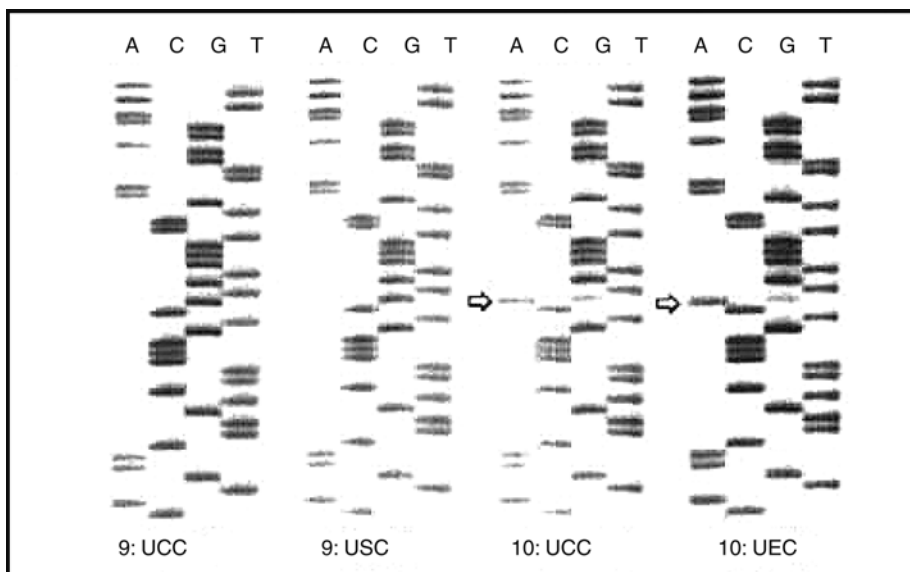

**Fig. 2.** *PTEN* exon sequence analysis (antisense) in two cases of mixed clear cell carcinoma. Case 9 is a mixed clear cell and serous carcinoma and case 10 is a mixed clear cell and endometrioid. In case 10, a basepair substitution (C to T transition) resulting in a nonsense mutation is seen in both components. No *PTEN* mutation was identified in case 9. UCC, uterine clear cell component; USC, uterine serous carcinoma component; UEC, uterine endometrioid component. (From ref. 24.)

### 3. MOLECULAR GENETICS OF UNCOMMON ENDOMETRIAL CARCINOMA

#### 3.1. Clear Cell Carcinoma

Clear cell carcinoma is an uncommon variant of endometrial carcinoma, and clinico-pathological studies have produced conflicting results regarding its biological behavior, with 5-year survival ranging from 21 to 75% (19–22). Furthermore, in addition to tumors that are pure clear cell carcinoma, clear cell differentiation can be admixed with tumors demonstrating endometrioid or serous components. Although, clear cell carcinoma is often categorized as a Type II tumor both the discrepancy in the biological behavior and its association with endometrioid and serous carcinoma suggests the possibility that it may not fit simply into the dualistic model of endometrial carcinoma.

Recent immunohistochemical studies using p53, Ki67, estrogen and progesterone receptors that were performed on clear cell carcinoma have suggested that they are different from either endometrioid or serous carcinoma (23). A recent molecular study demonstrated that the majority of pure clear cell carcinomas do not show mutations in either *PTEN* or *TP53*; the most commonly altered genes in type I and type II tumors, respectively (24). Furthermore, in tumors with a mixed histological appearance, the mutations present in the serous or endometrioid component were identical to those found in the clear cell component supporting a monoclonal origin of the distinct components (Fig. 2). These findings suggest that clear cell carcinoma may arise through different pathogenetic pathways, thus explaining the wide range of biological behavior. The absence of mutations in the *PTEN* gene and the *TP53* gene in the majority of pure



**Table 1**  
**Mutational Frequencies for TAM and NO-TAM Endometrial Cancers**

	<i>PTEN</i>	<i>K-RAS</i>	<i>TP53</i>	$\beta$ - <i>catenin</i>	<i>MI-positive</i>
TAM ( $n = 29$ )	10	5	7	1	7
NO-TAM ( $n = 29$ )	13	5	5	2	8

All  $p > 0.05$  for individual genetic mutational frequencies in TAM vs NO-TAM; calculated by two-tailed Fisher's exact test.

clear cell carcinomas implies that they arise through a distinct molecular pathway. It also emphasizes the need to separate pure from mixed clear cell carcinomas in future clinicopathological studies and should instigate a search for additional genetic changes in this variant of endometrial carcinoma to further the understanding of its pathogenesis and biological behavior.

#### 4. RELATIONSHIP OF HORMONES AND MOLECULAR GENETIC ALTERATIONS

One of the defining differences between type I and type II tumors is the association of type I tumors with an estrogenic state. Despite the fact that the relationship between estrogen and Type I tumors has been recognized for several decades little is known about the molecular basis of this association. Unopposed estrogen is rarely used anymore because of this strong association; however, tamoxifen use has increased and is currently the most widely prescribed hormonal therapy for the treatment of breast cancer. Although tamoxifen has an antiestrogenic effect in the breast, it has weak estrogenic effects on the endometrium. Many epidemiological as well as randomized prospective trials have shown a moderately increased risk of endometrial cancer in association with prolonged tamoxifen treatment with relative risks ranging from 2.53 to 7.5 (25–27). Thus, two recent studies have been done to determine the molecular profiles of tamoxifen associated tumors in the hope of providing insight into the mechanisms through which estrogen contributes to endometrial carcinoma development. A gene profiling study has found that the expression patterns of the tumors were associated most closely with tumor grade and were not associated with the presence or absence of tamoxifen exposure. In addition, a molecular genetic analysis of the most common genetic alterations in endometrial carcinoma, as discussed earlier, found no difference in the frequency of mutation between the two groups of tumors (Table 1).

These studies suggest that the mechanism by which tamoxifen increases the incidence of endometrial carcinoma is through the same pathogenetic pathways that give rise to sporadic cancer. Given these results, tamoxifen may act as an initiator of tumorigenesis through estrogen agonistic activity in the endometrium, according to the suggestions made by clinical trials and laboratory studies (26,28–32). An immunohistochemical study of endometrial epithelial proliferation in postmenopausal women showed increased staining with MIB-1 in tamoxifen-exposed benign endometrium compared to nonexposed endometrium. This further supports the idea that tamoxifen exposure results in increased epithelial proliferation (29). Thus, tamoxifen may act to increase the proliferation of a subset of cells, thereby increasing the likelihood of mutations.

Alternatively, it may promote the growth of cells that have already sustained mutations thereby enhancing the ability of “occult” malignancies to develop. As a result of either or both possibilities, tamoxifen exposure could lead to the production of a spectrum of mutations similar to that of sporadic endometrial cancers at the same time explaining the observation of an increased incidence of endometrial carcinoma in this clinical setting.

## 5. MOUSE MODEL OF ENDOMETRIOID CARCINOMA

As described previously, several studies have shown that MSI and mutations in *PTEN* are restricted with rare exceptions, to the estrogen-related endometrioid subtype of endometrial cancer. Furthermore, an association between MSI and *PTEN* mutations, the most common alterations in endometrioid carcinoma, has been identified, but the nature of the association remains unclear. Taken together, these data support a relationship not only between the two most common genetic alterations in uterine endometrioid component, but also suggest a fundamental relationship of these alterations with hormonal factors. Understanding these relationships is critical to unraveling the pathogenesis of endometrioid carcinoma. Valuable insights into the molecular genetics and hormonal aspects of endometrial carcinoma have come from the study of primary human tumors and *in vitro* studies. However, understanding the relationship of genetic alterations and hormones and their biological implications in endometrial tumorigenesis requires an *in vivo* model system.

Several studies have shown that 100% of female mice lacking one wild-type copy of *Pten* spontaneously develop a lesion that closely resembles complex atypical hyperplasia in humans. Furthermore, approx 20% of aged (32–40 weeks) mice develop invasive carcinoma with morphological similarities to well-differentiated endometrioid carcinoma (33,34). A recent study has also demonstrated that *Pten*<sup>+/-</sup> mice lacking a functional DNA mismatch repair system (*Pten*<sup>+/-</sup>/*Mlh*<sup>-/-</sup>) have an accelerated onset of hyperplasia and carcinoma (35). An analysis of the neoplastic lesions arising in both *Pten*<sup>+/-</sup> and *Pten*<sup>+/-</sup>/*Mlh*<sup>-/-</sup> mice show that the lesions (hyperplasias and carcinomas) demonstrate decreased expression of *Pten* by immunohistochemistry. In addition, in approx 30–60% of the lesions, loss of the wild-type allele of *Pten* was detected. These findings suggest that loss of *Pten* function is involved in the progression of endometrial tumorigenesis in this model system. Furthermore, in every lesion detected by light microscopic evaluation, irrespective of size or architecture, P-Akt was detected by immunohistochemical analysis. Although, other downstream targets in the Pten pathway may play a role in the development/progression of endometrial tumorigenesis, these studies indicate a central role for P-Akt.

In the future, this mouse model will be exploited to further our understanding of the pathogenesis of endometrial carcinoma at the molecular level and the interaction of genetic alterations and hormonal influences in this common malignancy of women.

## 6. CONCLUSION

Molecular genetic analysis in combination with histopathological features have provided key insights into the pathogenesis of endometrial carcinoma. The recent studies have supported a broad classification of endometrial carcinoma by documenting distinct molecular genetic profiles of the two most common histological types of the disease. These findings have not only elevated the understanding of this common malignancy of

the female genital tract, they have provided the fundamentals for developing new diagnostic and treatment modalities. Finally, these studies have set the stage for the construction of a mouse model that will give us the opportunity to study this tumor in a dynamic *in vivo* model, where the relationship of molecular genetic alterations and hormones can be further elucidated.

## REFERENCES

1. Tashiro H, Blazes MS, Wu R, et al. Mutations in PTEN are frequent in endometrial carcinoma but rare in other common gynecologic malignancies. *Cancer Res* 1997; 57: 3935–3940.
2. Levine RL, Cargile CB, Blazes MS, van Rees B, Kurman RJ, Ellenson LH. PTEN mutations and microsatellite instability in complex atypical hyperplasia, a precursor lesion to uterine endometrioid carcinoma. *Cancer Res* 1998; 58(15): 3254–3258.
3. Maxwell GL, Risinger JI, Gumbs C, et al. Mutation of the PTEN tumor suppressor gene in endometrial hyperplasias. *Cancer Res* 1998; 58(12): 2500–2503.
4. Maehama T, Dixon JE. The tumor suppressor, PTEN/MMAC1, dephosphorylates the lipid second messenger, phosphatidylinositol 3,4,5-trisphosphate. *J Biol Chem* 1998; 273(22): 13,375–13,378.
5. Sakurada A, Hamada H, Fukushige S, et al. Adenovirus-mediated delivery of the PTEN gene inhibits cell growth by induction of apoptosis in endometrial cancer. *Int J Oncol* 1999; 15(6): 1069–1074.
6. Zhu X, Kwon CH, Schlosshauer PW, Ellenson LH, Baker SJ. PTEN induces a G1 cell cycle arrest and decreases Cyclin D3 levels in endometrial carcinoma cells. *Cancer Res* 2001; 61(11): 4569–4575.
7. Soslow RA, Shen PU, Chung MH, Isacson C, Baergen RN. Cyclin D1 expression in high-grade endometrial carcinomas—association with histologic subtype. *Int J Gynecol Pathol* 2000; 19(4): 329–334.
8. Gurin CC, Federici MG, Kang L, Boyd J. Causes and consequences of microsatellite instability in endometrial carcinoma. *Cancer Res* 1999; 59(2): 462–466.
9. Mutter GL, Lin MC, Fitzgerald JT, et al. Altered PTEN Expression as a Diagnostic Marker for the Earliest Endometrial Precancers. *J Natl Cancer Inst* 2000; 92(11): 924–930.
10. Risinger JI, Hayes K, Maxwell GL, et al. PTEN mutation in endometrial cancers is associated with favorable clinical and pathologic characteristics. *Clin Cancer Res* 1998; 4(12): 3005–3010.
11. Esteller M, Levine R, Baylin SB, Ellenson LH, Herman JG. MLH1 promoter hypermethylation is associated with the microsatellite instability phenotype in sporadic endometrial carcinomas. *Oncogene* 1998; 17(18): 2413–2417.
12. Katabuchi H, van Rees B, Lambers AR, et al. Mutations in DNA mismatch repair genes are not responsible for microsatellite instability in most sporadic endometrial carcinomas. *Cancer Res* 1995; 55(23): 5556–5560.
13. Esteller M, Catusas L, Matias-Guiu X, et al. hMLH1 promoter hypermethylation is an early event in human endometrial tumorigenesis. *Am J Pathol* 1999; 155(5): 1767–1772.
14. Lax SF, Kendall B, Tashiro H, Slebos RJ, Hedrick L. The frequency of p53, K-ras mutations, and microsatellite instability differs in uterine endometrioid and serous carcinoma: evidence of distinct molecular genetic pathways. *Cancer* 2000; 88(4): 814–824.
15. Lukes AS, Kohler MF, Pieper CF, et al. Multivariable analysis of DNA ploidy, p53, and HER-2/neu as prognostic factors in endometrial cancer. *Cancer* 1994; 73: 2380–2385.
16. Fukuchi T, Sakamoto M, Tsuda H, Maruyama K, Nozawa S, Hirohashi S. Beta-catenin mutation in carcinoma of the uterine endometrium. *Cancer Res* 1998; 58(16): 3526–3528.
17. Kobayashi K, Sagae S, Nishioka Y, Tokino T, Kudo R. Mutations of the beta-catenin gene in endometrial carcinomas. *Japan J Cancer Res* 1999; 90(1): 55–59.
18. Tashiro H, Isacson C, Levine R, Kurman RJ, Cho KR, Hedrick L. p53 gene mutations are common in uterine serous carcinoma and occur as an early event in their pathogenesis. *Am J Pathol* 1997; 150(1): 177–185.
19. Carcangiu ML, Chambers JT. Early pathologic stage clear cell carcinoma and uterine papillary serous carcinoma of the endometrium: comparison of clinicopathologic features and survival. *Int J Gynecol Pathol* 1995; 14: 30–38.
20. Cirisano FD, Jr, Robboy SJ, Dodge RK, et al. The outcome of stage I-II clinically and surgically staged papillary serous and clear cell endometrial cancers when compared with endometrioid carcinoma. *Gynecol Oncol* 2000; 77(1): 55–65.
21. Giri PG, Schneider V, Belgrad R. Clear cell carcinoma of the endometrium: an uncommon entity with a favorable prognosis. *Int J Radiat Oncol Biol Phys* 1981; 7(10): 1383–1387.

22. Kanbour-Shakir A, Tobon H. Primary clear cell carcinoma of the endometrium: a clinicopathologic study of 20 cases. *Int J Gynecol Pathol* 1991; 10(1): 67–78.
23. Lax SF, Pizer ES, Ronnett BM, Kurman RJ. Clear cell carcinoma of the endometrium is characterized by a distinctive profile of p53, Ki-67, estrogen, and progesterone receptor expression. *Hum Pathol* 1998; 29(6): 551–558.
24. An HJ, Logani S, Isacson C, Ellenson LH. Molecular characterization of uterine clear cell carcinoma. *Mod Pathol* 2004; 17(5): 530–537.
25. Fornander T, Rutqvist LE, Cedermark B, et al. Adjuvant tamoxifen in early breast cancer: occurrence of new primary cancers. *Lancet* 1989; 1(8630): 117–120.
26. Fisher B, Costantino JP, Wickerham DL, et al. Tamoxifen for prevention of breast cancer: report of the National Surgical Adjuvant Breast and Bowel Project P-1 Study. *J Natl Cancer Inst* 1998; 90(18): 1371–1388.
27. Fisher B, Costantino JP, Redmond CK, Fisher ER, Wickerham DL, Cronin WM. Endometrial cancer in tamoxifen-treated breast cancer patients: findings from the National Surgical Adjuvant Breast and Bowel Project (NSABP) B-14. *J Natl Cancer Inst* 1994; 86(7): 527–537.
28. Wickerham DL, Fisher B, Wolmark N, et al. Association of tamoxifen and uterine sarcoma. *J Clin Oncol* 2002; 20(11): 2758–2760.
29. Mourits MJ, Ten Hoor KA, van der Zee AG, Willemse PH, de Vries EG, Hollema H. The effects of tamoxifen on proliferation and steroid receptor expression in postmenopausal endometrium. *J Clin Pathol* 2002; 55(7): 514–519.
30. Sakamoto T, Eguchi H, Omoto Y, Ayabe T, Mori H, Hayashi S. Estrogen receptor-mediated effects of tamoxifen on human endometrial cancer cells. *Mol Cell Endocrinol* 2002; 192(1–2): 93–104.
31. Shang Y, Brown M. Molecular determinants for the tissue specificity of SERMs. *Science* 2002; 295(5564): 2465–2468.
32. Stackievicz R, Drucker L, Radnay J, Beyth Y, Yarkoni S, Cohen I. Tamoxifen modulates apoptotic pathways in primary endometrial cell cultures. *Clin Cancer Res* 2001; 7(2): 415–420.
33. Podsypanina K, Ellenson LH, Nemes A, et al. Mutation of Pten/Mmac1 in mice causes neoplasia in multiple organ systems. *Proc Natl Acad Sci USA* 1999; 96(4): 1563–1568.
34. Stambolic V, Tsao MS, Macpherson D, Suzuki A, Chapman WB, Mak TW. High incidence of breast and endometrial neoplasia resembling human Cowden syndrome in pten+/- mice. *Cancer Res* 2000; 60(13): 3605–3611.
35. Wang H, Douglas W, Lia M, et al. DNA mismatch repair deficiency accelerates endometrial tumorigenesis in Pten heterozygous mice. *Am J Pathol* 2002; 160(4): 1481–1486.

# IV

---

## CERVICAL CANCER

---

# 7

---

## Natural History of HPV Infection in Adolescents and Relationship to Cervical Cancer

---

*Anna-Barbara Moscicki, MD*

### CONTENTS

INTRODUCTION

RATES OF HPV-DNA DETECTION AND ABNORMAL CYTOLOGY

ADOLESCENT BIOLOGICAL VULNERABILITY

NATURAL HISTORIES OF HPV, LSIL, AND HSIL IN ADOLESCENTS

CERVICAL CANCER SCREENING

LSIL TRIAGE

REFERENCES

---

### 1. INTRODUCTION

Cervical cytology screening programs have led to a decrease in the incidence and mortality of cervical cancer in the United States and other developed countries. Following the discovery of Human papillomavirus (HPV) as a potential cause of cervical cancer in the 1970s (1), subsequent epidemiological studies utilized sensitive HPV-DNA detection techniques to assess the prevalence of this virus in populations of all ages. Populations with a high prevalence of HPV infection were the same ones identified in earlier studies as being at high risk of developing cervical cancer. These included women who were young when they initiated sexual intercourse, had multiple sexual partners, and had other sexually transmitted infections (STIs) (2). Several studies in the 1980s also reported that adolescents in the United States had very high rates of unprotected sexual intercourse, STIs, and multiple sexual partners (3). Similarly, women in this age group had high rates of HPV infection (4,5).

In addition to high rates of HPV infection, it was also noted that the cervical cancer precursor, cervical intraepithelial neoplasia (CIN), or recently termed as squamous intraepithelial lesion (SIL), also occurred in high rates in adolescents (5,8). This is not surprising because SIL is the morphological manifestation of HPV replication and protein expression. Moreover, the presence of active squamous metaplasia in adolescents appears to play an important role in the support of viral replication.

From: *Current Clinical Oncology: Molecular Pathology of Gynecologic Cancer*  
Edited by: A. Giordano, A. Bovicelli, and R. Kurman © Humana Press Inc., Totowa, NJ

The high rates of SIL found in sexually active adolescents led to the implementation of screening practices in the United States that targeted sexually active adolescents and young women at any age (9–11). Not surprisingly, the new screening practices resulted in an enormous increase in referrals for colposcopy and treatment. Epidemiology studies during the last decade have broadened the understanding of the natural history of HPV, and have shown that young women do not benefit from cervical cancer screening and that watchful observation is often the best management for low-grade SIL (LSIL). The American Cancer Society recently published new guidelines, which support initiating cervical cytology screening after 3 years of the onset of vaginal sexual intercourse, but no later than 21 years of age (12). Follow-up and management of LSIL have also been altered for adolescents to ensure LSIL can be safely followed by cytology or HPV-DNA testing (13). This chapter discusses the prevalence and natural history of HPV and SIL in adolescents as well as the biological factors associated with vulnerability to HPV and its consequences in this age group. Finally, this chapter covers the new guidelines in the United States based on these observations.

## 2. RATES OF HPV-DNA DETECTION AND ABNORMAL CYTOLOGY

As HPV-DNA testing methodology evolved and improved in sensitivity and specificity, HPV was detected in 75–90% of precancers (SILs) and 99% of invasive cancers (14). The lower prevalence rate of HPV in the SILs compared with invasive cancers is likely because of misclassification of SIL, particularly LSIL. The higher the grade of the lesion, less likely there is misclassification and more likely HPV is detected (15). The prevalence of HPV is higher in younger women than older women, but the overall prevalence of high grade lesions is lower in young women.

Younger women have HPV rates up to six to eightfold than that of older women. Prevalence rates range from 12 to 56% in women under 21 years compared with 2–7% in women more than 35 years of age (4,5,16,17). Although, some countries have prevalence rates that begin to rise again after the age of 50 years, the rates do not reach to those of young women (18). Approximately, 50% of adolescents and young women acquire a cervical HPV infection within 5–7 years after initiating sexual intercourse with the highest risk factor being a recent new sexual partner (19). As previously discussed LSIL is the morphological manifestation of cervical HPV infections and high rates of LSIL would therefore be expected in this group. Rates of LSIL range from 2 to 14% (20–22) in adolescents whereas in older women (>30 years) the rates range from 0.6 to 1%. However, it is important to emphasize that HPV detection in adolescents is most commonly associated with normal cytology. More than three-quarters of infected adolescents have normal cytology (19).

Rates of high-grade SIL (HSIL) are substantially lower in adolescent populations. Mount and colleagues (8) examined more than 10,000 Pap smears from young women in New England and found that 14% of the smears from women aged 15–19 years were abnormal with only 0.7% having HSIL and no cases of invasive cancer. In this same cohort, approx 0.8% of women aged 20–29 years and 0.7% aged 30–39 years had HSIL. Although, these rates are similar, biopsy-proven HSIL is generally higher in older women. In a nationwide organized cervical screening program in Norway, 0.2% of 20,000 smears from adolescents aged 15–19 years were reported as having HSIL (21). The high rates of SIL, predominantly LSIL was responsible for referring large

number of young women to colposcopy in the United States in the 1990s as LSIL was considered by many at that time to be a precancerous lesion. Moreover, there was a consensus that setting HSIL as the threshold for referral to colposcopy was too high.

### 3. ADOLESCENT BIOLOGICAL VULNERABILITY

Young age at first intercourse has long been associated with risk for invasive cancer. The risk of invasive cancer increases twofold in women who initiate sexual intercourse under the age of 18 years as compared with those initiating sexual intercourse after 19 years when controlling the number of lifetime sex partners (23). This finding suggests that there is a certain biological vulnerability of the cervix of young women to HPV infection. The adolescent cervix is structurally different from the cervix of adult women (6). It frequently has a mosaic appearance with different cellular components including relatively large areas of columnar and metaplastic squamous epithelium. Although, the adult cervix also contains these components, the predominant cell type in adults is the mature squamous cell. Both columnar and metaplastic squamous cells are vulnerable to HPV probably for a variety of reasons of which thinness of the epithelium may be one factor.

Once sexual activity is initiated, active immature squamous metaplasia occurs. This process is characterized by replacement of the columnar epithelium by rapidly proliferating immature squamous epithelium. This rapidly proliferating cellular population is presumably vulnerable to HPV infection resulting not only in replication of the virus, but also accompanying viral induced genetic alterations in the host metaplastic squamous epithelium, which if infection persists can lead to HSIL. Cervical maturity, in which immature metaplastic epithelium is transformed to mature glycogenated epithelium in adolescent populations is directly correlated with the number of sexual partners (24,25). Although, the mature squamous epithelium provides more protective barrier to HPV than the thin columnar epithelium, the process of transformation creates a fertile environment for HPV infection and development of SIL.

Understanding the life cycle of HPV clarifies the role of cervical immaturity in viral acquisition, persistence, and development of SIL. It is believed that HPV gains access to basal cells in the squamous epithelium as a result of small tears in the superficial layers of the squamous epithelium during sexual intercourse or through inflammatory processes. HPV replication and patterns of transcription are highly dependent on the differentiation program of keratinocytes in the cervical squamous epithelium with transcription of HPV proteins E6 and E7 occurring shortly after infection (26). HPV E6 and E7 are important oncoproteins with well-described transformation properties (27). As cells go through differentiation, the infected cell expresses E1, E2, and E4 viral proteins. It is not until the cell has undergone terminal differentiation that HPV expresses large amounts of its capsid proteins, L1 and L2, for the final formation of infectious virions. Immature metaplastic squamous epithelium in adolescents supports viral replication because of the rapid cellular proliferation and differentiation of the metaplastic cells. The expression of E6, E7, and E4 proteins results in basal cell proliferation, nuclear enlargement, and abnormal mitotic figures, similar to features of SIL (28). A study of adolescent women showed that those with evidence of active metaplasia based on colposcopy were more likely to develop LSIL if infected with HPV than adolescents with a relatively quiescent cervix (29). In a longitudinal study of HPV infection in adolescents 50% acquired HPV and



more than one-quarter of those developed LSIL, underscoring the common manifestation of productive HPV infection as LSIL in this age group (19).

Factors that influence or induce squamous metaplasia are not well defined. Because of the active immature squamous metaplasia during adolescence compared with childhood, the influence of estrogen is believed to be important. However, other factors including local trauma and infection have also been shown to induce metaplasia. Several decades ago, Singer et al. (24) showed that adolescents who had initiated intercourse, and reported several sexual partners were more likely to have mature cervixes covered predominantly by squamous epithelium in comparison with virginal adolescents whose cervixes were predominantly covered by columnar epithelium. In a recent study of high-risk adolescents using colpophotographical descriptions, the more the number of sexual partners the more likely these women had a mature cervix (25). These studies suggest that factors associated with sexual intercourse (i.e., sperm, STIs) may be capable of inducing metaplasia and increase the risk of HPV and LSIL. Schachter et al. (30) showed that *Chlamydia trachomatis* was associated with metaplasia on histology, suggesting that inflammation and repair can induce the process of squamous metaplasia. In a longitudinal study of adolescents, having HSV antibodies was an independent risk factor for acquiring HPV (19).

#### 4. NATURAL HISTORIES OF HPV, LSIL, AND HSIL IN ADOLESCENTS

For more than a decade, numerous studies have documented the transient nature of HPV infection in young women. Although, up to 50% of adolescents acquire HPV in adolescence approx 90% will clear the infection, (31–33) with 79–90% clearing it within 24 months. Certain HPV types, such as HPV 16, clear more slowly than other high- or low-risk types and new infections are constantly occurring. There is evidence that having multiple types of HPVs also slow clearance (34). Whether this reflects a global defect in the immune response or whether multiple HPV types act synergistically is unclear. The remaining 5–20% of women with persistent infections are at risk for developing HSIL (31,35,36). Rates of regression among older women appear to be less frequent; hence, detection of HPV in an older woman (defined as >30 years) most likely reflects an already persistent infection and an increased risk for HSIL.

As with HPV, LSIL, and HSIL also regress at higher rates in adolescents compared with older women (37–39). Studies in adult women show that 60–80% of LSIL will spontaneously regress and 20–30% will progress to HSIL. In contrast, a recent study in adolescents and young women show higher rates of regression with 92% of women aged 13–22 years showing regression (40). As demonstrated by these high rates of appearance and regression, LSIL appears to regress in parallel with HPV underscoring its benign nature in this population. The slower rate of regression of LSIL observed in older women compared with adolescents is most likely because of an infection that is already persistent. Persistence of viral infection has been shown in many studies to be necessary for the development of significant precancers, i.e., HSIL (31,35,36). Another reason may be that the chance of the LSIL being misclassified is higher (the lesion is actually HSIL) in the older women because the prevalence of histological HSIL is higher in this older age group. In more recent studies (41,42), about 80–90% of LSIL was shown to regress in adult women. The difference between the older studies and the more recent ones may be that the prevalence of certain behaviors differed,

for example, smoking and use of high dose estrogen contraceptives that may have influenced regression.

Actual progression rates of SILs remain unknown because all studies are time-limited. Cox et al. (43) showed that 12.8% of older women would progress from LSIL or ASCUS/HPV-positive to HSIL within 2 years (41,43). On the other hand, Woodman et al. (44) noted that 3% of HPV-negative and 7% of HPV-positive adolescents developed HSIL within 19 months of acquiring HPV. In a longitudinal study of adolescents and young women (40), only 3% of LSIL in adolescents and young women progressed to HSIL within 3 years. A retrospective chart review of adolescents less than 19 years of age with cytological LSIL found that 31% progressed to HSIL by 36 months (45). As this study involved chart reviews, it is not clear if the HSIL reflected new lesions or actual progression of LSIL. In addition, only a third of the original cohort was followed for 36 months. Studies of HSIL are few because carcinoma-*in situ* is part of what has recently been termed HSIL and there are ethical concerns in monitoring these lesions without treatment. Another problem with the interpretation of studies of HSIL are that this category subsumes the WHO categories of CIN 2 and CIN 3 and these lesions have different natural histories. Furthermore, CIN 2 is not a very reproducible diagnosis by pathologists. There is also debate as to whether CIN 2 behaves more like CIN 1 or more like CIN 3 (37). The importance of these differences for adolescents is that CIN 2 lesions make up the majority of HSIL whereas CIN 3 is less common (8,20). In a study of adult women, Syrjanen et al. (37) reported that 56% of CIN 1, 53% of CIN 2, and 14% of the CIN 3 lesions regressed. Progression rates were similar as 14% of CIN 1 and 21% of CIN 2 progressed in comparison with 69% of CIN 3. Nassiel et al. (38) found similar rates of regression for CIN 2 lesions, but with slightly higher progression rates overall (30%).

Prevalence studies in adolescents in United States have consistently shown that adolescents rarely have carcinoma-*in situ* and that invasive cancer is almost unheard of (8,20). According to the most recent Surveillance Epidemiology and End Results (SEER) statistics (1995–1999), the incidence of invasive cancer of the cervix was 0 per 100,000 for ages 10–14 years; 0 per 100,000 for ages 15–19 years and 1.7 per 100,000 for ages 20–24 (46). The 1.7 cases per 100,000 cases in the 20–24 year olds may have been in at risk populations, such as those with immunodeficiency disorders.

## 5. CERVICAL CANCER SCREENING

As discussed earlier, the high rates of HPV and abnormal cytology in adolescents began the movement to screen all sexually active women including young adolescents in the United States (9–11). The guidelines also proposed that once screening was initiated, if three consecutive annual Pap smears were normal, screening intervals could be extended to every 3 years except for “high risk” women who should be screened annually. All adolescent women who are sexually active are often considered high risk (9) because adolescents have the highest rates of STIs including *Neisseria gonorrhoeae* and *C. trachomatis* (3,47,48). The low sensitivity of a single smear fueled the recommendations for early and frequent screening (49). However, new data suggest that even if adolescents are not screened within 3 years after the onset of sexual activity the chances of any HPV progressing to carcinoma-*in situ* are extremely rare. Whereas, screening and discovering abnormal cytological smears create unnecessary referrals.

Although, most care providers agree that cervical cancer screening in adolescents yield low benefits, the age limit to begin screening remains controversial. The American Cancer Society's Committee upper age limit of 21 years was primarily based on expert opinion. Using mathematical modeling as reported in Saslow's report for the American Cancer Society (12) the most cost effective HPV testing strategy is to start screening 3 years after the age of sexual onset, with a cap at 25 years. In theory this would catch more than 97% of young women. In the United States, 21 years of age was considered a more realistic age for compliance and access to patients, particularly, in the absence of an organized screening system. The safety net is there for providers who do not ask and for young women who do not answer the question about when they initiated sexual intercourse. In countries with organized screening, such as the United Kingdom, new recommendations where to start screening at 25 years (49a). In contrast, Australia recommends a screening interval of 2 years for women who have had no symptoms or history suggestive of abnormal cytology commencing between the ages of 18–20 years or 1–2 years after first sexual intercourse, whichever is later (49b). Clearly, some cases of invasive cancer are missed when screening begins after 20 years of age.

## 6. LSIL TRIAGE

LSIL is a benign disease in young women. The higher rate of regression of LSIL in adolescents compared with adult women led to more reasonable guidelines (13). Conservative observation of LSIL by cytology rather than immediate referral to colposcopy in adolescents and young women is now accepted. In the United States, it is recommended that a young woman with LSIL return in 6 months for repeat cytology. Any abnormality on repeat cytology leads to referral to colposcopy. However, in adolescents regression may take up to 36 months (40). Hence, close observation with repeat cytology every 6 months up to 2 years is reasonable. Appearance of HSIL on cytology at any follow-up visit should be referred to colposcopy. Alternatively, adolescents can return in a year for HPV testing (13). The evidence for this recommendation is sparse. The rationale is that the increased sensitivity of HPV testing compared with cytology allows for longer intervals of follow-up. The presence of HPV at 1 year after a LSIL diagnosis is believed to reflect HPV persistence and hence, increased risk for HSIL development. However, in adolescents, the chances of the HPV infection reflecting persistent infection are low. It is far more likely that the HPV detected at 1-year follow-up reflects a new infection unrelated to the previous LSIL diagnosis. On the other hand, if the HPV test is negative, the LSIL has most likely regressed allowing the individual to be put back into standard screening.

Although, HPV testing is now being implemented in many countries for primary screening, the data clearly show that for primary screening in adolescents, HPV testing is not recommended. As mentioned previously, HPV detection in a woman more than 30 years of age who is in a monogamous relationship most likely reflects persistent infection. In contrast, detection of HPV in adolescents and young women most likely reflects an incident and transient infection.

In summary, although HPV is undoubtedly the cause of cervical cancer, HPV detection is not a specific sign of cervical cancer. In fact, in adolescents it is quite common with more than 50% acquiring HPV within 5 years after the onset of sexual intercourse. Although, HPV is a common infection, it is transient in most women. Persistence of

HPV is a key factor in the development of invasive cancer. However, natural history studies show that invasive cancers do not evolve within 3 years after exposure to HPV even with HPV persistence. Understanding the natural history of HPV in adolescents sheds light on the high rate of HPV infection reported in this age group. However, the association between age of first intercourse and invasive cancer cannot be ignored. Accordingly, although screening shortly after initiating intercourse is not necessary, adolescents who initiate sexual activity are vulnerable to HPV infection. Nonetheless, persistence is an important risk factor and development of invasive cancer usually takes decades. Recommendations for screening should assess risk based on behavior not simply on chronological age.

## REFERENCES

1. zur Hausen H. Human papillomaviruses and their possible role in squamous cell carcinomas. *Curr Top Microbiol Immunol* 1977; 78: 1–30.
2. Castellsague X, Bosch FX, Munoz N. Environmental co-factors in HPV carcinogenesis. *Virus Res* 2002; 89(2): 191–199.
3. Mosher WD, Chandra A, Jones J. Sexual behavior and selected health measures: men and women 15–44 years of age, United States, 2002. *Adv Data* 362: 1–55, 2005.
4. Moscicki AB, Palefsky J, Gonzales J, Schoolnik G. Human papillomavirus infection in sexually active adolescent females: Prevalence and risk factors. *Pediatr Res* 1990; 28: 507–513.
5. Rosenfeld WD, Vermund SH, Wentz SJ, et al. High prevalence rate of human papillomavirus infection and association with abnormal Papanicolaou smears in sexually active adolescents. *Am J Dis Child* 1989; 143: 1443–1447.
6. Singer A. The cervical epithelium during puberty and adolescence. In: *The Cervix* (Gordon JA, Singer A, eds.), WB Saunders, Philadelphia, 1978, 87.
7. Apter D, Viinikka L, Vihko R. Hormonal pattern of adolescent menstrual cycles. *J Clin Endocrinol Metab* 1978; 47(5): 944–954.
8. Mount SL, Papillo JL. A Study of 10,296 Pediatric and Adolescent Papanicolaou Smear Diagnoses in Northern New England. *Pediatrics* 1999; 103(3): 539–546.
9. American College of Obstetricians and Gynecologists. ACOG Guidelines for Women’s Health Care. Washington, DC: The American College of Obstetricians and Gynecologists, 1996.
10. NIH. NIH releases consensus statement on cervical cancer. *Am Fam Physician* 1996; 54(7): 2310.
11. Elster, A. The American Medical Association Guidelines for Adolescent Preventive Services. *Arch Pediatr Adolesc Med* 1997; 151(9): 958–959.
12. Saslow D, Runowicz CD, Solomon D, et al. American Cancer Society guideline for the early detection of cervical neoplasia and cancer. *CA Cancer J Clin* 2002; 52(6): 342–362.
13. Wright TCJ, Cox JT, Massad LS, Twiggs LB, Wilkinson EJ. 2001 Consensus Guidelines for the management of women with cervical cytological abnormalities. *JAMA* 2002; 287(16): 2120–2129.
14. Munoz N, Bosch FX, de Sanjose S, et al. Epidemiologic classification of human papillomavirus types associated with cervical cancer. *N Engl J Med* 2003; 348(6): 518–527.
15. Crum CP, Genest DR, Krane JF, et al. Subclassifying atypical squamous cells in Thin-Prep cervical cytology correlates with detection of high-risk human papillomavirus DNA. *Am J Clin Pathol* 1999; 112(3): 384–390.
16. Moscicki AB, Ellenberg JH, Vermund SH, et al. Prevalence of and risks for cervical human papillomavirus infection and squamous intraepithelial lesions in adolescent girls: impact of infection with human immunodeficiency virus. *Arch Ped Adolesc Med* 2000; 154: 127–134.
17. Ferreccio C, Prado RB, Luzoro AV, et al. Population-based prevalence and age distribution of human papillomavirus among women in Santiago, Chile. *Cancer Epidemiol Biomarkers Prev* 2004; 13(12): 2271–2276.
18. Herrero R, Hildesheim A, Bratti C, et al. Population-based study of human papillomavirus infection and cervical neoplasia in rural Costa Rica. *J Natl Cancer Inst* 2000; 92(6): 464–474.
19. Moscicki AB, Hills N, Shiboski S, et al. Risks for incident human papillomavirus infection and low-grade squamous intraepithelial lesion development in young females. *JAMA* 2001; 285(23): 2995–3002.

20. Sadeghi SB, Hsieh EW, Gunn SW. Prevalence of cervical intraepithelial neoplasia in sexually active teenagers and young adults. *Am J Obstet Gynecol* 1984; 148: 726–729.
21. Bjorge T, Gunbjorud AB, Langmark F, Skare GB, Thoresen SO. Cervical Mass Screening in Norway—510,000 Smears a Year. *Cancer Detection Prev* 1994; 18(6): 463–470.
22. Schydlower LTM, Greenberg MH, Patterson CPH. Adolescents with Abnormal Cervical Cytology. *Clin Pediatr* 1981; 20(11): 723–726.
23. Green J, Berrington de Gonzalez A, Sweetland S, et al. Risk factors for adenocarcinoma and squamous cell carcinoma of the cervix in women aged 20–44 years: the UK National Case-Control Study of Cervical Cancer. *Br J Cancer* 2003; 89(11): 2078–2086.
24. Singer A. The uterine cervix from adolescence to the menopause. *Br J Obstet Gynaecol* 1975; 82(2): 81–99.
25. Moscicki AB, Ma Y, Holland C, Vermund SH. Cervical ectopy in adolescent girls with and without human immunodeficiency virus infection. *J Infect Dis* 2001; 183(6): 865–870.
26. Taichmain LB, LaPorta RF. The expression of papillomaviruses in epithelial cells. In: *The papovaviridae* (Salzman NP, ed.), The Papillomaviruses. New York, Plenum, 1986, vol. 2, pp. 109–130.
27. Longworth MS, Laimins LA. Pathogenesis of Human Papillomaviruses in Differentiating Epithelia. *Microbiol Mol Biol Rev* 2004; 68(2): 362–372.
28. Solomon D, Davey D, Kurman R, et al. The 2001 Bethesda System: terminology for reporting results of cervical cytology. *JAMA* 2002; 287(16): 2114–2119.
29. Moscicki AB, Grubbs-Burt V, Kanowitz S, Darragh T, Shiboski S. The significance of squamous metaplasia in the development of low grade squamous intra-epithelial lesions in young women. *Cancer* 1999; 85: 1139–1144.
30. Schachter J, Hill EC, King EB, Coleman VR, Jones P, Meyer KF. Chlamydial infection in women with cervical dysplasia. *Am J Obstet Gynecol* 1975; 123(7): 753–757.
31. Moscicki AB, Shiboski S, Broering J, et al. The natural history of human papillomavirus infection as measured by repeated DNA testing in adolescent and young women. *J Pediatr* 1998; 132: 277–284.
32. Ho GY, Bierman R, Beardsley L, Chang CJ, Burk RD. Natural History of cervicovaginal papillomavirus infection in young women. *NEJM* 1998; 338(7): 423–428.
33. Evander M, Edlund K, Gustafsson A, et al. Human Papillomavirus Infection is Transient in Young Women: A Population-Based Cohort Study. *J Infect Dis* 1995; 171: 1026–1030.
34. Moscicki AB, Ellenberg JH, Farhat S, Xu J. Persistence of human papillomavirus infection in HIV-infected and -uninfected adolescent girls: risk factors and differences, by phylogenetic type. *J Infect Dis* 2004; 190(1): 37–45.
35. Koutsky LA, Holmes KK, Critchlow CW, et al. A cohort study of the risk of cervical intraepithelial neoplasia grade 2 or 3 in relation to papillomavirus infection. *NEJM* 1992; 327: 1272–1278.
36. Brown FM, Faquin WC, Sun D, Crum CP, Cibas ES. LSIL biopsies after HSIL smears. Correlation with high-risk HPV and greater risk of HSIL on follow-up. *Am J Clin Pathol* 1999; 112(6): 765–768.
37. Syrjanen K, Kataja V, Yliskoski, Chang F, Syrjanen S. Natural History of Cervical Human Papillomavirus Lesions Does Not Substantiate the Biologic Relevance of the Bethesda System. *Obstet Gynecol* 1992; 79: 675–682.
38. Nassiel K, Nassiel M, Vaclavinkova V. Behavior of Moderate Cervical Dysplasia During Long Term Follow-Up. *Obstet Gynecol* 1983; 61: 609–614.
39. Nash JD, Burke TW, Hoskins WJ. Biologic course of cervical human papillomavirus infection. *Obstet Gynecol* 1987; 69: 160–162.
40. Moscicki AB, Shiboski S, Hills NK, et al. Regression of low-grade squamous intra-epithelial lesions in young women. *Lancet* 2004; 364(9446): 1678–1683.
41. Lee SS, Collins RJ, Pun TC, Cheng DK, Ngan HY. Conservative treatment of low grade squamous intraepithelial lesions (LSIL) of the cervix. *Int J Gynaecol Obstet* 1998; 60(1): 35–40.
42. Schlecht NF, Platt RW, Duarte-Franco E, et al. Human papillomavirus infection and time to progression and regression of cervical intraepithelial neoplasia. *J Natl Cancer Inst* 2003; 95(17): 1336–1343.
43. Cox JT, Schiffman M, Solomon D. ASCUS-LSIL Triage Study (ALTS) Group. Prospective follow-up suggests similar risk of subsequent cervical intraepithelial neoplasia grade 2 or 3 among women with cervical intraepithelial neoplasia grade 1 or negative colposcopy and directed biopsy. *Am J Obstet Gynecol* 2003; 188(6): 1406–1412.
44. Woodman CB, Collins S, Winter H, et al. Natural history of cervical human papillomavirus infection in young women: a longitudinal cohort study. *Lancet* 2001; 357(9271): 1831–1836.
45. Wright JD, Davila RM, Pinto KR, et al. Cervical dysplasia in adolescents. *Obstet Gynecol* 2005; 106(1): 115–120.

46. Ries LAG, Harkins D, Krapcho M, et al. *SEER Cancer Statistics Reivew, 1975–2003*, National Cancer Institute, Bethesda, MD, [http://seer.cancer.gov/csr/1975\\_2003/](http://seer.cancer.gov/csr/1975_2003/), based on November 2005 SEER data submission, posted to the SEER web site, 2006.
47. Moscicki AB, Millstein SG, Broering J, Irwin CE. Risks of human immunodeficiency virus infection among adolescents attending three diverse clinics. *J Pediatr* 1993; 122: 813–820.
48. Shafii T, Burstein GR. An overview of sexually transmitted infections among adolescents. *Adolesc Med Clin* 2004; 15(2): 201–214.
49. ASCUS-LSIL Traige Study (ALTS) Group. Results of a randomized trial on the management of cytology interpretations of atypical squamous cells of undetermined significance. *Am J Obstet Gynecol* 2003; 188(6): 1383–1392.
- 49a. National Health Services Cancer Screening Programme, [www.cancerscreening@nhs.uk/cervical.index.html#invited](http://www.cancerscreening@nhs.uk/cervical.index.html#invited).
- 49b. National Health and Medical Research Council Guidelines Screening to prevent cervical cancer, [www.nhmc.gov.cvu/publications](http://www.nhmc.gov.cvu/publications).
50. Smith JS, Green J, Berrington de Gonzalez A, et al. Cervical cancer and use of hormonal contraceptives: a systematic review. *Lancet* 2003; 361(9364): 1159–1167.
51. Smith JS, Bosetti C, Munoz N, et al. *Chlamydia trachomatis* and invasive cervical cancer: a pooled analysis of the IARC multicentric case-control study. *Int J Cancer* 2004; 111(3): 431–439.
52. Moscicki AB, Ellenberg JH, Crowley-Nowick P, Darragh TM, Xu J, Farhat S. Risk of high grade squamous intra-epithelial lesions in HIV infected adolescents. *J Infect Dis* 2004; 190(8): 1413–1421.
53. Centers For Disease Control. USPHS/IDSA Guidelines for the prevention of opportunistic infections in persons infected with human immunodeficiency virus: A summary. *Morb Mortal Wkly Rep* 1995; 44: 1–34.

# 8

---

## Molecular Genetics of Cervical Cancer

---

*Valeria Masciullo, MD, PhD*  
*and Antonio Giordano, MD, PhD*

### CONTENTS

INTRODUCTION  
CELL CYCLE AND HPV  
P53 POLYMORPHISM  
INTEGRATION OF HPV DNA INTO THE HOST GENOME  
HUMAN IMMUNODEFICIENCY VIRUS AND CERVICAL CANCER  
BIOLOGICAL MARKERS EXPRESSED IN CERVICAL CARCINOMA  
ANGIOGENESIS AND CERVICAL CANCER  
CHROMOSOMAL ALTERATIONS AND CERVICAL CANCER  
CONCLUSIONS  
REFERENCES

---

### 1. INTRODUCTION

The carcinoma of the uterine cervix is the second most common cancer among women worldwide, with its higher incidence in developing countries (1). Strong clinical and experimental evidence demonstrated that the high-risk (HR) types of human papilloma virus (HPV) play a central role in causing cervical cancer, although a role of multiple risk factors has been suggested too. Not only does the epidemiological data indicate the criteria of causality on HPV and cervical cancer, but also there are several studies that identified the viral transforming genes, and their mode of action supports a model of multistep carcinogenesis. It is generally accepted that the development of invasive cervical cancer from intraepithelial neoplasia (cervical intraepithelial neoplasia [CIN]1–2/3) involves molecular changes and therefore is a preventable if detected and treated early. The vast majority of low-grade squamous intraepithelial lesions (LSILs) regress spontaneously and it is estimated that about 10–20% of high-grade SILs (HSILs) are at risk of progressing into invasive cancer.

Despite the success of screening programs, cervical carcinoma continues to be diagnosed especially in underscreened and unscreened populations. Present research spans the spectrum from understanding the epidemiology of HPV infection, including its natural history, to understanding the molecular biology of cervical cancer. Identification of molecular changes as a result of HPV infection can lead to new therapies to treat existing cervical cancer and, in the long-term, to prevent the disease.

From: *Current Clinical Oncology: Molecular Pathology of Gynecologic Cancer*  
Edited by: A. Giordano, A. Bovicelli, and R. Kurman © Humana Press Inc., Totowa, NJ

## 2. CELL CYCLE AND HPV

The HPVs are a family of DNA viruses with more than 150 genotypes. More than 40 of these genotypes infect the anogenital tract, causing a range of diseases from genital wart to invasive cancers. Certain types are considered more carcinogenic in humans; HPV-16 and HPV-18 probably are the most carcinogenic types. Integration of HPV DNA into a host genome has been hypothesized to play an important role in the carcinogenesis of HPV-related carcinomas. It is postulated that HSILs might originate from mild dysplasia or arise directly from infection by HR-HPV. There are three different oncoproteins encoded from the E5, E6, and E7 viral genes. E5 protein is not expressed in cervical cancer. High-grade squamous intraepithelial lesions are usually monoclonal and harbor HR-HPV genotypes in 90% of cases, with high expression of viral oncoproteins E6 and E7.

Together, E6 and E7 are responsible for the induction as well as the maintenance of the transformed phenotype of cervical cancer cells by binding with multiple cellular targets (2). Although HPV certainly has many actions in the infected cells, two of the major effects are on two tumor suppressor genes, *p53* and Retinoblastoma (*Rb*). *p53* is an housekeeping gene able to recognize when DNA damage has occurred in a cell, arresting that cell in G<sub>1</sub> phase of the cell cycle to allow for DNA repair or, if repair is not possible, to lead that cell into cell death. Although mutation or deletion of the *p53* gene is one of the most common genetic abnormalities in malignancies, *p53* mutations in cervical cancer are rare (3). Instead, E6 binds with (through the 100-kd “E6-associated” cellular protein [E6-AP]), and inactivates *p53* causing its degradation through the ubiquitin system (4). The inactivation of *p53* by HPV E6 oncoprotein also leads to the upregulation of cyclin B (5), which regulates transition from G<sub>2</sub> to M phase.

The retinoblastoma tumor-suppressor protein pRb and its related pocket proteins pRb2/p130 and p107 (6), regulate the cell cycle at the G<sub>1</sub>/S restriction point by complexing with and inhibiting the activity of E2F, which serves as a transcription-dependent promoter of cell cycle progression. In the presence of HPV oncoprotein E7, the E2F–pRb complex dissociates activating E2F, which initiates the transcription of genes required for DNA replication and thus inappropriately forcing the cell past the G<sub>1</sub>/S point into S phase (7,8). Therefore, the deregulation of pRb leads to an increased transcription of cyclin E by E2F. The functional inactivation of pRb by HPV E7 also results in the reciprocal overexpression of p16, because of a negative feedback-loop between pRb (see “*p16 and Ki-67*”). In combination, the E6/*p53* and E7/pRb interactions seem to compromise the accuracy of mitosis. In addition, HPV E6 can activate the telomere-lengthening enzyme telomerase independent of *p53* binding, and E7 can induce abnormal centrosome duplication through a mechanism independent of inactivation of pRb and its family members. These latter properties may also contribute to the transforming characteristics of these viral oncoproteins.

## 3. *p53* POLYMORPHISM

Storey (9) implicated the proline/arginine polymorphism of the codon 72 of the tumor-suppressor gene *p53* in the development of cervical cancer, with the observation that the *p53* protein is more efficiently inactivated by the E6 oncoprotein of human papillomavirus in *p53* arginine as compared with its proline isoform. These authors further noted that in the United Kingdom, individuals homozygous for the arginine allele were sevenfold more



susceptible to HPV-associated tumorigenesis than proline/arginine heterozygote. Subsequent studies in different countries failed to unanimously confirm this association. This discrepancy in the result could be because of the small sample sizes investigated by different groups and the quality of DNA and controls used for the analysis.

Meta-analysis studies (10,11) showed a trend toward the ARG72ARG *p53* polymorphism being associated with increased risk of developing cervical cancer; however, these data must be confirmed by larger studies.

#### 4. INTEGRATION OF HPV DNA INTO THE HOST GENOME

Integration of HPV DNA into a host genome has been shown to positively correlate with the severity of the lesions, supporting the hypothesis that integration is an important event during carcinogenesis. The main effect of viral integration is the loss of *E2* gene sequences through disruption of the episomal genome. HR-HPV genomes replicate as episomal molecules in the normal viral life cycle. Despite being controlled by *E2* (12), *E6* and *E7* induce severe chromosomal instability associated with centrosome aberrations, anaphase bridges, chromosome lagging, and breaking. Integration seems to be a direct consequence of chromosomal instability and an important molecular event in the progression of preneoplastic lesions. Disruption or deregulation of defined critical cellular gene functions by insertional mutagenesis (13) and by integrated HPV genome fragments has been hypothesized as one major promoting factor in the pathogenesis of HPV-associated cancers. This hypothesis was based on the detection of HPV integration events in the area of tumor-relevant genes in few cases. Ferber et al. (14,15) described HPV integration to occur within or close to the *MYC* gene locus and in the area of the telomerase gene. Thus, it is conceivable that interference of viral sequences with critical cellular sequences contribute essentially to the enhanced progression risk of HPV-induced preneoplasia into neoplastic lesions.

Another possible explanation for progression toward malignant lesions after HR-HPV integration might be structural changes of the viral genome that allow enhanced and deregulated expression of the viral oncogenes and thereby confer the additional neoplastic advantage. It was shown that HPV *E6*- and *E7*-encoding complementary DNAs derived from integrated viral oncogene transcripts, confer a much stronger transforming capacity in primary cells as compared with complementary DNAs derived from episome-derived transcripts. This was attributed to the longer half-life of transcripts derived from integrated HPV DNA, mediated by 3'-cellular sequences of the fusion transcripts (16). In specific cervical cancer cell lines only one or few integrated genomes are transcribed, whereas (17) clinical samples harbor only few integration sites, with the majority thereof being actively transcribed (18). Taken together, these observations suggest that integration of the viral genome renders viral gene expression independent of viral control mechanisms and allows selection of cell clones with deregulated viral oncogene expression favoring the outgrowth of neoplastic cell clones.

Two different assays have been applied to analyze genomic HPV integration sites: the first is the "detection of integrated papillomavirus sequences polymerase chain reaction," which detects the integration site of the virus at the human genome on DNA probe. The other test is the amplification of papillomavirus oncogene transcripts assay, which detects transcripts of integrated viral DNA. Both tests open the future to the possibility of using viral integration as the surrogate marker for progression of precursors to invasive cancer.

## 5. HUMAN IMMUNODEFICIENCY VIRUS AND CERVICAL CANCER

Human immunodeficiency virus (HIV) is a retrovirus belonging to the lentivirus family and is the causative agent of AIDS. Numerous studies have documented a high prevalence of HPV coinfection (19), with an increase in both latent and symptomatic HPV infection. HIV alters the natural history of HPV infection with decreased regression rates and more rapid progression to high-grade and invasive lesions, resulting in a more aggressive phenotype. High-grade lesions have been associated with both high- and low-risk HPV types, leading to speculation that HIV may increase the oncogenicity of the HR types, and possibly the activity of low-risk types also (20). However, whereas the development of AIDS-related malignancies, such as Kaposi's sarcomas and non-Hodgkin's lymphoma are attributable to immune deficiency, the relation between HIV and cervical cancer remains to be elucidated.

There are two major pathways involved in cervical cancer tumorigenesis. The first is the loss of heterozygosis (LOH) (*see* 8); the other involves genetic instability at the microsatellite loci (MSI). This instability originates as a result of defects in the mismatch repair genes, making them unable to repair errors occurring during replication. Loss of cell-cycle checkpoints could also cause this instability. MSI occurs at low rate in cervical cancer (8–10%) (21); however, a significantly higher frequency of MSI has been observed in HIV-related CIN lesions, and these changes were independent from the HIV-induced immune suppression (22). Thus, it is possible that HIV-associated cervical cancers may progress through the microsatellite instability pathway, whereas HIV negative ones progress through LOH.

## 6. BIOLOGICAL MARKERS EXPRESSED IN CERVICAL CARCINOMA

Although, more than 99% of all cervical cancers are associated with HPV infection, only a fraction of HPV-infected women develop cervical cancer. Thus, tumor formation following HPV infection most likely is the result of a multistep carcinogenesis process in which HPV provides the initial hit, whereas activation of other pathways may serve as the second hit.

### 6.1. *Wnt/Wingless Pathway*

Wnt/Wingless signaling pathway is involved in various pathological conditions including cancer. Wnt proteins' binding with their transmembrane receptors activate a canonical pathway, which is characterized by accumulation of  $\beta$ -catenin in the cytoplasm and in the nucleus. Activation of the receptors leads to the phosphorylation of the disheveled protein, through its association with AXIN1 and then prevents glycogen synthase kinase 3 from phosphorylating critical substrates, such as  $\beta$ -catenin. Thus, inhibiting its cytoplasm degradation. Excess  $\beta$ -catenin then goes to the nucleus to form an active transcriptional complex with T-cell factor, which activates transcription of target genes including *c-myc* and *cyclin D1*. Although, different components of the Wnt-signaling pathway are mutated in human cancer, only a few studies reported mutation of  $\beta$ -catenin and axin 1 in cervical cancer (23,24). However, a recent study (25) suggests that transformation of HPV-expressing human keratinocytes requires activation of the Wnt pathway as the second hit and that such activation may serve as a screening tool in HPV-positive population to detect cervical malignant progression.

## 6.2. Fragile Histidine Triad Gene

Genomic instability has been found in cervical neoplasia and commonly involves the short arm of chromosome 3 in the fragile histidine triad (*FHIT*) gene (3p14.2). The presence of aberrant *FHIT* transcripts was found to be generated by alternative splicing of exons 5, 7, and 10 and of introns 5 and 7 (26).

LOH at 3p14.2 region was found to be progressive with increasing cervical lesions from CIN to invasive cancer, suggesting that loss of *FHIT* could represent an early event in the pathogenesis of cervical carcinoma (27). However, the prognostic role of loss of *FHIT* expression in this tumor is still controversial (28,29). Recent evidence suggests that *FHIT* instability may play a synergistic role with HR-HPV in the pathogenesis of high-grade cervical lesions. In fact HPV can integrate into FRA3B, the most active chromosome breakage site contained in the 3p14.2 region (30).

Other risk factors, as cigaret smoking (31), alcohol consumption, or concurrent chronic inflammation can target *FHIT* locus, accounting for the development of those high-grade cervical lesions, which are not associated with HR-HPV. Thus, suggesting that the presence of abnormal fragile histidine triad transcripts could itself be an independent risk factor associated with an alternative carcinogenic pathway (32).

## 6.3. p16 and Ki-67

The p16 protein plays a key role in controlling cell growth by inhibiting the cyclin-dependent kinase-4 and preventing phosphorylation of pRb, which maintains the G<sub>1</sub> checkpoint. Several studies (33,34) have suggested that p16 is overexpressed in CIN and invasive adenocarcinoma as a result from HPV E7-mediated degradation of pRb through an ubiquitin-dependent mechanism. However, studies by methylation-specific polymerase chain reaction *in situ* showed that neoplastic cells with aberrantly methylated p16 were associated with the loss of p16 protein expression (35). Thus, suggesting that p16 hypermethylation can negate the seemingly protective role of p16 overexpression in response to HPV infection. p16 silencing by aberrant methylation is strongly associated with active tobacco use in squamous cell cervical cancer and high-grade dysplasia (36).

The Ki-67 protein plays an important although not entirely characterized role in cell proliferation. Its antigen is expressed during the cell cycle with the exception of the G<sub>0</sub> phase, and has been used as a marker for proliferation in various tumors, including cervical carcinoma. Previous studies have shown that application of Ki67 immunohistochemical analyses of CIN1 and CIN2 in histological biopsies has strong independent predictive value for grade, presence of oncogenic HPV, and progression of the disease (37,38). The best Ki67-feature combination to predict whether a subsequent higher CIN grade or cancer will be detected in the follow-up, is the 90th percentile of the stratification index (Si90) and the percent of Ki67-positive cells in the middle third layer of the epithelium (38). Ki67 prognostic value exceeds that of CIN grade (as CIN1 or CIN2) and the presence of HR-HPV types assessed by PCR, highlighting its clinical relevance in cervical cancer outcome.

## 6.4. Epidermal Growth Factor Receptor

The epidermal growth factor receptor (EGFR) family consists of four structurally related transmembrane receptors: EGFR (HER-1 or Erb-B1), HER2neu (c-erbB-2),

HER-3, and HER-4. In response to ligand-specific binding, these receptors act by forming hetero- or homodimers and thereby initiate tyrosine kinase activity in the intracellular domain. The oncogenic pathway of some cells is believed to start as a result of HER2neu and/or EGFR mutation, overexpression, structural rearrangements, and/or relief of normal regulatory or inhibitory pathways. Increased expression of HER2-neu and decreased EGFR membranous staining identified an improved disease-free survival and an overall survival in patients with cervical cancer (39,40). On the other hand, other studies have also revealed no correlation with clinical outcome (41,42). The conflicting results may be because of differences in institutional treatment standards and to the variability of immunohistochemical techniques and the “cut-off” used in the statistical analysis.

Recently, many therapeutic agents targeting this receptor have entered the clinical and phase II trials of both small-molecule inhibitors of EGFR and antibody-based inhibitors underway in cervical cancer. However, emerging data suggest that their activity in unselected women with advanced cancer is very modest, raising the possibility that these agents could be highly effective in a small subset of patients whose tumors are dependent on EGFR signaling.

### ***6.5. Cyclooxygenase-2***

Several reports have recently highlighted the biological and clinical role of cyclooxygenase (COX)-2, the key enzyme in the conversion of arachidonic acid to prostaglandins, in the pathogenesis and natural history of human cancer (43). In particular, COX-2 overexpression is involved in the inhibition of apoptosis, increased metastatic potential and neoangiogenesis, and impairment of host immune responses. Moreover, COX-2 has been associated with parameters of tumor aggressiveness and unfavorable prognosis in several solid tumors including colorectal, breast, ovarian, and cervical cancer. Several reports have shown that high COX-2 expression in tumor cells characterizes cervical cancer patients with poor survival, regardless of the type of primary treatment (44,45). Moreover, COX-2 status could provide additional information to identify patients with cervical cancer with a poor chance of response to neoadjuvant treatment and unfavorable prognosis (46).

### ***6.6. The Keratin Patterns***

Keratins filament proteins have a specific distribution pattern in epithelial tissues that change during neoplastic transformation of the uterine cervix. Of particular interest are the changes that occur in keratins 8, 10, 13, and 17. Keratin 8 was identified in endocervical columnar cells, whereas keratin 17 in endocervical reserve cells. They are both expressed during malignant transformation of human cervix and are suggestive of progression when present in CIN I, II, and III lesions. In contrast, keratins 10 and 13 are expressed in ectocervical epithelium and are expressed in well-differentiated areas and in keratin pearls of squamous carcinomas (47).

Expressions of keratins 8 and 17 increased from reference cervix to invasive carcinomas; in contrast expressions of keratins 10 and 13 were lost with increasing severity of lesions. Expressions of keratins 8 and 17 were significantly more frequent in CIN III lesions and invasive carcinomas, suggesting that both keratins are highly specific markers of malignant transformation in the human cervix. A recent study (48),

investigating a possible diagnostic use of keratins in cervical cancer, concluded that increase in the expressions of keratins 8 and 17 and loss in the expressions of keratins 10 and 13 are good markers of malignant phenotype. Moreover, the expression pattern of keratin 10 could be useful for subtyping and grading squamous cell carcinoma of the cervix.

### 6.7. The Matrix Metalloproteinases

Enzymatic degradation of the extracellular matrix represents a key element in the multistage process of tumor invasion. Recently, a specific group of enzymes that are known as the matrix metalloproteinases (MMPs) or the matrixins family has shown to be involved in the degradation of extracellular matrix. Among the MMPs, the type IV collagenases are the ones that showed the highest activity and among this class the MMP-2 is the one that has the highest collagenolytic activity and the best association with tumoral progression. The MMP-2 is secreted in humans by cells like fibroblasts, endothelial cells, keratinocytes, and macrophages. MMP-2 expression is increased in inflammatory processes as well as in malignant neoplasia. High MMP-2 levels have been frequently reported in cervical cancer (49,50). Moreover, MMP-2 expression increases gradually from cervical intraepithelial neoplasia (CIN I, II, and III) to cervical carcinoma (51).

Recent studies have highlighted the key role of the membrane type I MMP-1 in cervical cancer. Specifically, MMP-1 expression is very low or absent in normal cervix and LSILs, is readily detectable in HSILs, and is very strongly expressed in nearly all invasive carcinomas (52). Moreover, genetic polymorphisms of MMP-1 are prognostic markers in patients with invasive cervical cancer (53).

## 7. ANGIOGENESIS AND CERVICAL CANCER

Angiogenesis is the development of new blood vessels from preexisting capillaries and is a critical step in the growth, progression, and metastasis of tumors. The degree of angiogenesis has also been associated with the prognosis of neoplasm. Several studies suggest that angiogenesis might be involved in the development and progression of cervical tumors and that microvessel density could represent an important clinical prognostic factor (54).

Despite the small number of studies, the expression of several angiogenetic factors seems to play a promising role in cervical tumors. Vascular endothelial growth factor, basic fibroblast growth factor, and transforming growth factor (TGF $\beta$ )1 correlate with the malignant transformation of uterine cervix (55). Whereas CD34, an antigen present in endothelial cells is a very sensitive marker for vascular tumors whose expression in early cervical squamous cell carcinoma (Ib-IIa) is associated with pathoanatomical features indicative of poor prognosis (56).

## 8. CHROMOSOMAL ALTERATIONS AND CERVICAL CANCER

Although, cytogenetic studies on cervical cancer have identified a number of non-random karyotypic changes involving chromosomes 1, 3, 5, 17, and X, the search for the critical genetic changes has been hampered by technical difficulties, such as the karyotypic complexity of this tumor. The advent of comparative genomic hybridization has opened a novel means of characterizing genomic imbalances and to date several studies have identified 3q gain, which occurred at severe dysplasia/carcinoma *in situ*.

This lead to the suggestion that this genetic aberration plays a role in the transition from dysplasia to invasive cervical cancer (57,58). A number of studies in this region have identified the candidate oncogenes, such as *PIK3CA*, which encodes a catalytic subunit of phosphatidylinositol 3-kinase and has been already implicated in ovarian and cervical carcinomas (59).

Other chromosomal changes involve loss of 2q, 3p, 4p, 4q, 5q, 6q, 11q, 13q, and 18q regions and gain of 1q, 3q, 5p, and 8q at various stages of cervical cancer (60). LOH was also frequently found at 3p, 4p, 4q, 5p, 6p, 6q, 11q, and 17p chromosomal regions, suggesting the presence of putative tumor suppressor genes on these chromosomes (61). The *TSLC1* gene (also known as IGSF4 or NECL-2) might be one of the candidate suppressors of tumorigenicity on chromosome 11. This gene, which maps at 11q23, encodes an immunoglobulin-like cell surface protein that belongs to the nectin and nectin-like family of proteins and is involved in cell–cell adhesions. *TSLC1* was found to be silenced in 91% (10/11) of cervical cancer cell lines, mostly as a result of promoter hypermethylation alone or combined with allelic loss. Promoter hypermethylation was also present in 58% of cervical carcinomas and 35% of high-grade CIN lesions, but not in low-grade CIN lesions and normal cervix (62). However, ectopic expression of *TSLC1* is able to suppress only anchorage-independent growth of SiHA cells, suggesting that these cells become tumorigenic as a result of an additional hit.

Recurrent sites of amplification were noted at 11q13, 11q21, and 19q13.1 and were more commonly associated with HPV18 infection (63). This relationship is interesting in the light of the oncogenic potential of this HPV type, which is known to cause rapid transition to malignancy and to characterize a more aggressive phenotype. Although, amplification of specific genes, as *HER-2/neu*, has already been shown to predict clinical outcome in cervical cancer (64), the identification of additional genes at specific chromosomal sites are needed to provide new insights into the clinical behavior and management of this tumor.

## 9. CONCLUSIONS

Every year approximately half a million women develop cervical cancer of whom 80% live in poor countries where population-based screening programs are virtually nonexistent. Although, 95% of the patients with precancerous lesions harbor HPV, only a small fraction of the cases eventually progress to invasive cancer. Therefore, HPV infection alone is considered insufficient for the malignant conversion, suggesting the role of other genetic changes in the development of cervical cancer.

Molecular characterization of chromosomal changes utilizing new genomic technologies should provide important clues of the genetic mechanisms of initiation and progression and new insight into the clinical behavior and management of cervical cancer. Early detection of cervical cancer precursor lesions by screening procedures and their treatment, will remain the most important measures for the control of this disease in the foreseeable future. Thus, a major aim is to identify women who are at risk of developing cancer as it provides opportunities for prevention and treatment of the disease.

With the rapid evolving of molecular technology, in the not-so-distant future, it may be expected to see patients with cervical cancer treated with targeted vaccines or molecular therapies.

## REFERENCES

1. Bosch FX, De Sanjose S. Chapter 1: Human papillomavirus and cervical cancer—burden and assessment of causality. *J Natl Cancer Inst Monogr* 2003; 31: 3–13.
2. Munger K, Howley PM. Human papillomavirus immortalization and transformation functions. *Virus Res* 2002; 89: 213–228.
3. Thomas M, Pim D, Banks L. The role of the E6–p53 interaction in the molecular pathogenesis of HPV. *Oncogene* 1999; 18: 7690–7700.
4. Scheffner M, Huibregtse JM, Vierstra RD, Howley PM. The HPV-16 E6 and E6–AP complex functions as a ubiquitin-protein ligase in the ubiquitination of p53. *Cell* 1993; 75: 495–505.
5. Kaufmann WK, Schwartz JL, Hurt JC, et al. Inactivation of G2 checkpoint function and chromosomal destabilization are linked in human fibroblasts expressing human papillomavirus type 16 E6. *Cell Growth Differ* 1997; 8: 1105–1114.
6. Masciullo V, Khalili K, Giordano A. The Rb family of cell cycle regulatory factors: clinical implications. *Int J Oncol* 2000; 17: 897–902.
7. Dyson N, Howley PM, Munger K, Harlow E. The human papilloma virus-16 E7 oncoprotein is able to bind to the retinoblastoma gene product. *Science* 1989; 243: 934–937.
8. Lavia P, Mileo AM, Giordano A, Paggi MG. Emerging roles of DNA tumor viruses in cell proliferation: new insights into genomic instability. *Oncogene* 2003; 22: 6508–6516.
9. Storey A, Thomas M, Kalita A, et al. Role of a p53 polymorphism in the development of human papillomavirus-associated cancer. *Nature* 1998; 393: 229–234.
10. Jee SH, Won SY, Yun JE, Lee JE, Park JS, Ji SS. Polymorphism p53 codon-72 and invasive cervical cancer: a meta-analysis. *Int J Gynaecol Obstet* 2004; 85: 301–308.
11. Koushik A, Platt RW, Franco EL. p53 codon 72 polymorphism and cervical neoplasia: a meta-analysis review. *Cancer Epidemiol Biomarkers Prev* 2004; 13: 11–22.
12. Sanchez-Perez AM, Soriano S, Clarke AR, Gaston K. Disruption of the human papillomavirus type 16 E2 gene protects cervical carcinoma cells from E2F-induced apoptosis. *J Gen Virol* 1997; 78: 3009–3018.
13. Thorland EC, Myers SL, Persing DH, et al. Human papillomavirus type 16 integrations in cervical tumors frequently occur in common fragile sites. *Cancer Res* 2000; 60: 5916–5921.
14. Ferber MJ, Thorland EC, Brink AA, et al. Preferential integration of human papillomavirus type 18 near the c-myc locus in cervical carcinoma. *Oncogene* 2003; 22: 7233–7242.
15. Ferber MJ, Montoya DP, Yu C, et al. Integrations of the hepatitis B virus (HBV) and human papillomavirus (HPV) into the human telomerase reverse transcriptase (hTERT) gene in liver and cervical cancers. *Oncogene* 2003; 22: 3813–3820.
16. Jeon S, Allen-Hoffmann BL, Lambert PF. Integration of human papillomavirus type 16 into the human genome correlates with a selective growth advantage of cells. *J Virol* 1995; 69: 2989–2997.
17. Van Tine BA, Knops J, Broker TR, Chow LT, Moen PT Jr. *In situ* analysis of the transcriptional activity of integrated viral DNA using tyramide-FISH. *Dev Biol (Basel)* 2001; 106: 381–385.
18. Ziegert C, Wentzensen N, Vinokurova S, et al. A comprehensive analysis of HPV integration loci in anogenital lesions combining transcript and genome-based amplification techniques. *Oncogene* 2003; 22: 3977–3984.
19. Sun XW, Ellerbrock TV, Lungu O, Chiasson MA, Bush TJ, Wright TC Jr. Human papillomavirus infection in human immunodeficiency virus-seropositive women. *Obstet Gynecol* 1995; 85: 680–686.
20. Tweddel G, Heller P, Cunnane M, Mulhaupt H, Roth K. The correlation between HIV seropositivity, cervical dysplasia, and HPV subtypes 6/11, 16/18, 31/33/35. *Gynecol Oncol* 1994; 52: 161–164.
21. Wong YF, Cheung TH, Poon KY, et al. The role of microsatellite instability in cervical intraepithelial neoplasia and squamous cell carcinoma of the cervix. *Gynecol Oncol* 2003; 89: 434–439.
22. Wistuba II, Syed S, Behrens C, et al. Comparison of molecular changes in cervical intraepithelial neoplasia in HIV-positive and HIV-indeterminate subjects. *Gynecol Oncol* 1999; 74: 519–526.
23. Ueda M, Gemmill RM, West J, et al. Mutations of the beta- and gamma-catenin genes are uncommon in human lung, breast, kidney, cervical and ovarian carcinomas. *Br J Cancer* 2001; 85: 64–68.
24. Su TH, Chang JG, Yeh KT, et al. Mutation analysis of CTNNB1 (beta-catenin) and AXIN1, the components of Wnt pathway, in cervical carcinomas. *Oncol Rep* 2003; 10: 1195–1200.
25. Uren A, Fallen S, Yuan H, et al. Activation of the canonical Wnt pathway during genital keratinocyte transformation: a model for cervical cancer progression. *Cancer Res* 2005; 65: 6199–6206.
26. Greenspan DL, Connolly DC, Wu R, et al. Loss of FHIT expression in cervical carcinoma cell lines and primary tumors. *Cancer Res* 1997; 57: 4692–4698.

27. Wistuba II, Montellano FD, Milchgrub S, et al. Deletions of chromosome 3p are frequent and early events in the pathogenesis of uterine cervical carcinoma. *Cancer Res* 1997; 57: 3154–3158.
28. Baykal C, Ayhan A, Al A, Yuce K, Ayhan A. No relationship is indicated between FHIT expression and clinicopathologic prognostic parameters in early stage cervical carcinoma. *Int J Gynecol Cancer* 2003; 13: 192–196.
29. Takizawa S, Nakagawa S, Nakagawa K, et al. Abnormal Fhit expression is an independent poor prognostic factor for cervical cancer. *Br J Cancer* 2003; 88: 1213–1216.
30. Muller CY, O'Boyle JD, Fong KM, et al. Abnormalities of fragile histidine triad genomic and complementary DNAs in cervical cancer: association with human papillomavirus type. *J Natl Cancer Inst* 1998; 90: 433–439.
31. Holschneider CH, Baldwin RL, Tumber K, Aoyama C, Karlan BY. The fragile histidine triad gene: a molecular link between cigarette smoking and cervical cancer. *Clin Cancer Res* 2005; 11: 5756–5763.
32. Terry G, Ho L, Londesborough P, Cuzick J. Abnormal FHIT expression profiles in cervical intraepithelial neoplastic (CIN) lesions. *Br J Cancer* 2002; 86: 376–381.
33. Sano T, Oyama T, Kashiwabara K, Fukuda T, Nakajima T. Expression status of p16 protein is associated with human papillomavirus oncogenic potential in cervical and genital lesions. *Am J Pathol* 1998; 153: 1741–1748.
34. Tringler B, Gup CJ, Singh M, et al. Evaluation of p16INK4a and pRb expression in cervical squamous and glandular neoplasia. *Hum Pathol* 2004; 35: 689–696.
35. Nuovo GJ, Plaia TW, Belinsky SA, Baylin SB, Herman JG. *In situ* detection of the hypermethylation-induced inactivation of the p16 gene as an early event in oncogenesis. *Proc Natl Acad Sci USA* 1999; 96: 12754–12759.
36. Lea JS, Coleman R, Kurien A, et al. Aberrant p16 methylation is a biomarker for tobacco exposure in cervical squamous cell carcinogenesis. *Am J Obstet Gynecol* 2004; 190: 674–679.
37. Kruse AJ, Baak JP, de Bruin PC, et al. Ki-67 immunoquantitation in cervical intraepithelial neoplasia (CIN): a sensitive marker for grading. *J Pathol* 2001; 193: 48–54.
38. Kruse AJ, Baak JP, Janssen EA, et al. Low- and high-risk CIN 1 and 2 lesions: prospective predictive value of grade, HPV, and Ki-67 immuno-quantitative variables. *J Pathol* 2003; 199: 462–470.
39. Kersemaekers AM, Fleuren GJ, Kenter GG, et al. Oncogene alterations in carcinomas of the uterine cervix: overexpression of the epidermal growth factor receptor is associated with poor prognosis. *Clin Cancer Res* 1999; 5: 577–586.
40. Lee CM, Lee RJ, Hammond E, et al. Expression of HER2neu (c-erbB-2) and epidermal growth factor receptor in cervical cancer: prognostic correlation with clinical characteristics, and comparison of manual and automated imaging analysis. *Gynecol Oncol* 2004; 93: 209–214.
41. Scambia G, Ferrandina G, Distefano M, D'Agostino G, Benedetti-Panici P, Mancuso S. Epidermal growth factor receptor (EGFR) is not related to the prognosis of cervical cancer. *Cancer Lett* 1998; 123: 135–139.
42. Leung TW, Cheung AN, Cheng DK, Wong LC, Ngan HY. Expressions of c-erbB-2, epidermal growth factor receptor and pan-ras proto-oncogenes in adenocarcinoma of the cervix: correlation with clinical prognosis. *Oncol Rep* 2001; 8: 1159–1164.
43. Dannenberg AJ, Altorki NK, Boyle JO, et al. Cyclooxygenase-2: a pharmacological target for the prevention of cancer. *Lancet Oncol* 2001; 2: 544–551.
44. Kim YB, Kim GE, Cho NH, et al. Overexpression of cyclooxygenase-2 is associated with a poor prognosis in patients with squamous cell carcinoma of the uterine cervix treated with radiation and concurrent chemotherapy. *Cancer* 2002; 95: 531–539.
45. Ferrandina G, Ranalletti FO, Legge F, et al. Cyclooxygenase-2 (COX-2) expression in locally advanced cervical cancer patients undergoing chemoradiation plus surgery. *Int J Radiat Oncol Biol Phys* 2003; 55: 21–27.
46. Ferrandina G, Lauriola L, Distefano MG, et al. Increased cyclooxygenase-2 expression is associated with chemotherapy resistance and poor survival in cervical cancer patients. *J Clin Oncol* 2002; 20: 973–981.
47. Smedts F, Ramaekers F, Troyanovsky S, et al. Keratin expression in cervical cancer. *Am J Pathol* 1992; 141: 497–511.
48. Carrilho C, Alberto M, Buane L, David L. Keratins 8, 10, 13, and 17 are useful markers in the diagnosis of human cervix carcinomas. *Hum Pathol* 2004; 35: 546–551.
49. Davidson B, Goldberg I, Gotlieb WH, et al. High levels of MMP-2, MMP-9, MT1-MMP and TIMP-2 mRNA correlate with poor survival in ovarian carcinoma. *Clin Exp Metastasis* 1999; 17: 799–808.



50. Sheu BC, Hsu SM, Ho HN, Lien HC, Huang SC, Lin RH. A novel role of metalloproteinase in cancer-mediated immunosuppression. *Cancer Res* 2001; 61: 237–242.
51. Gaiotto MA, Focchi J, Ribalta JL, et al. Comparative study of MMP-2 (matrix metalloproteinase 2) immune expression in normal uterine cervix, intraepithelial neoplasias, and squamous cells cervical carcinoma. *Am J Obstet Gynecol* 2004; 190: 1278–1282.
52. Zhai Y, Hotary KB, Nan B, et al. Expression of membrane type 1 matrix metalloproteinase is associated with cervical carcinoma progression and invasion. *Cancer Res* 2005; 65: 6543–6550.
53. Lai HC, Chu CM, Lin YW, et al. Matrix metalloproteinase 1 gene polymorphism as a prognostic predictor of invasive cervical cancer. *Gynecol Oncol* 2005; 96: 314–319.
54. Ozalp S, Yalcin OT, Oner U, Tanir HM, Acikalin M, Sarac I. Microvessel density as a prognostic factor in preinvasive and invasive cervical lesions. *Eur J Gynaecol Oncol* 2003; 24: 425–428.
55. Soufla G, Sifakis S, Baritaki S, Zafiroopoulos A, Koumantakis E, Spandidos DA. VEGF, FGF2, TGF $\beta$ 1 and TGF $\beta$ R1 mRNA expression levels correlate with the malignant transformation of the uterine cervix. *Cancer Lett* 2005; 221: 105–118.
56. Vieira SC, Silva BB, Pinto GA, et al. CD34 as a marker for evaluating angiogenesis in cervical cancer. *Pathol Res Pract* 2005; 201: 313–318.
57. Heselmeyer K, Schrock E, du Manoir S, et al. Gain of chromosome 3q defines the transition from severe dysplasia to invasive carcinoma of the uterine cervix. *Proc Natl Acad Sci USA* 1996; 93: 479–484.
58. Heselmeyer K, Macville M, Schrock E, et al. Advanced-stage cervical carcinomas are defined by a recurrent pattern of chromosomal aberrations revealing high genetic instability and a consistent gain of chromosome arm 3q. *Genes Chromosomes Cancer* 1997; 19: 233–240.
59. Ma YY, Wei SJ, Lin YC, et al. PIK3CA as an oncogene in cervical cancer. *Oncogene* 2000; 19: 2739–2744.
60. Umayahara K, Numa F, Suehiro Y, et al. Comparative genomic hybridization detects genetic alterations during early stages of cervical cancer progression. *Genes Chromosomes Cancer* 2002; 33: 98–102.
61. Chatterjee A, Pulido HA, Koul S, et al. Mapping the sites of putative tumor suppressor genes at 6p25 and 6p21.3 in cervical carcinoma: occurrence of allelic deletions in precancerous lesions. *Cancer Res* 2001; 61: 2119–2123.
62. Steenbergen RD, Kramer D, Braakhuis BJ, et al. TSLC1 gene silencing in cervical cancer cell lines and cervical neoplasia. *J Natl Cancer Inst* 2004; 96: 294–305.
63. Rao PH, Arias-Pulido H, Lu XY, et al. Chromosomal amplifications, 3q gain and deletions of 2q33-q37 are the frequent genetic changes in cervical carcinoma. *BMC Cancer* 2004; 4: 5.
64. Mitra AB, Murty VV, Li RG, Pratap M, Luthra UK, Chaganti RS. Allelotype analysis of cervical carcinoma. *Cancer Res* 1994; 54: 4481–4487.

# 9

---

## Prevention and Treatment of Cervical Cancer by Vaccination

---

*Hannah H. Alphas, BS, T-C Wu, MD, PhD,  
and Richard B. S. Roden, PhD*

### CONTENTS

CERVICAL CANCER  
HPV BIOLOGY  
VACCINATION AGAINST HUMAN PAPILLOMAVIRUS  
CONCLUSIONS  
REFERENCES

---

## 1. CERVICAL CANCER

### *1.1. Etiology: Human Papillomaviruses*

Causality requires a judgment based on scientific evidence from human and experimental studies, as strict causality studies are often not appropriate in humans. Evidence linking certain human papillomavirus (HPV) genotypes to cervical carcinoma is extensive and compelling. More than two decades of research has led to the fulfillment of criteria, as proposed by Hill, to establish a causal link between high risk HPV infection and cervical cancer (Table 1). HPV DNA was first isolated from biopsies of cervical cancer more than 30 years ago (1,2). HPV DNA is detected in 99.7% of cervical carcinomas worldwide. The evidence overwhelmingly demonstrates that persistent high risk HPV infection is a necessary but not sufficient cause of this cancer (3).

Harald zur Hausen's group in 1985 first cloned the archetypal and most common high risk HPV genotype, HPV-16, from a cervical cancer (4). A decade later, HPV was officially recognized as a human carcinogen by the World Health Organization (5). HPV has been found to induce transformation of human uterine cervix (6) and additionally, expression of high risk HPV whole genome (7) or the E6 and E7 viral oncogenes (8) immortalize human keratinocytes. Serum antibody to high risk HPV has also been found to be associated with malignant and premalignant lesions of the cervix (9,10). Recent preventive vaccine trials confirm that virus capsid-specific immunity is elicited in 99.7% patients (11) and protects against persistent HPV infection and the development of cervical intraepithelial neoplasia (CIN), the precancerous precursor to cervical cancer presently termed squamous intraepithelial lesions (SIL).

From: *Current Clinical Oncology: Molecular Pathology of Gynecologic Cancer*  
Edited by: A. Giordano, A. Bovicelli, and R. Kurman © Humana Press Inc., Totowa, NJ

**Table 1**  
**Association of HPV With Cervical Cancer**

<i>Criteria</i>	<i>Compliance of HPV as a cause of cervical cancer</i>
Strength of association	One of the strongest ever observed for human cancer. High-risk HPV DNA is present in 99.7% of cervical cancers (3). Serum antibody to high risk-HPV associated with malignant and premalignant lesions of the cervix (9,10).
Consistency	Consistent association between HPV DNA detection and cervical cancer across a large number of studies and diverse populations.
Specificity	Only specific HPV types are associated with cervical cancer.
Temporality	HPV infection precedes CIN and occurs many years before the onset of cervical cancer. The epidemiology of HPV infection is consistent with the known sexually transmitted nature of cervical cancer.
Biological gradient	The risk to develop cervical cancer increases with viral load and persistent infection (40).
Plausibility	Plausible based on coherence of previous in vitro studies in animals and observational studies in humans.
Coherence	Does not conflict with what is known about the natural history and biology of the virus and disease progression.
Experimental evidence	Identification of HPV DNA in biopsies of cervical cancer (1,2). Production of virus by raft culture of CIN-derived cells Transformation of human uterine cervix by HPV (6). Expression of high-risk HPV whole genome (7) and E6 and E7 oncogenes (8) immortalization of human keratinocytes. Derepression of HPV E6 and E7 oncogenes has been observed in cervical tumor cells (102). Suppression of expression tumorigenesis in cervical carcinoma cell lines by blockade of HPV E6 and E7 oncogene expression (103).
Analogy	Analogous both to the induction of cancers by animal papillomaviruses, and also a number of other viruses, such as HBV and EBV that are known to cause human cancers.

Application of epidemiological considerations for causal inference to human papillomavirus and cervical cancer. This table summarizes an extensive review from ref. 131.

Papillomaviruses are double-stranded DNA viruses belonging to the family Papovaviridae. Nearly 100 HPV genotypes have been designated to date and close to 100 other types have been identified (12). The papillomaviruses fall into two major groups, dermatotropic and mucosotropic. Dermatotropic HPV types have a propensity for cutaneous epithelium and are associated with generally benign warts. Mucosotropic HPV types target mucous membranes, commonly infecting the penis, perineum, perianal region, vagina, vulva, and cervix. Genital Mucosa Tropic HPV infections are considered the most common sexually transmitted infection in the United States (13) and previous studies estimate that up to 75% of sexually active men and women will become infected with HPV at some time in their life (14). The major manifestations of genital HPV infection include genital warts (condyloma acuminatum) and SILs of the anogenital region.

Approximately 35 of the nearly 100 types of HPV are specific for the anogenital epithelium and have varying potentials for malignant transformation. The International Agency for Research on Cancer (IARC) Multicenter Cervical Cancer Study Group recently reported that fifteen mucosatropic HPV types can be considered high-risk types (16, 18, 31, 33, 35, 39, 45, 51, 52, 56, 58, 59, 68, 73, and 82); three can be considered probable high-risk types (26, 53, and 66); and 12 can be considered low-risk types (6, 11, 40, 42, 43, 44, 54, 61, 70, 72, 81, and CP6108) (15). Low-risk types, such as HPV6 and 11 do not integrate into the host genome and are only associated with lower-grade genital tract SILs and benign warts. Intermediate-risk types can cause higher-grade SILs, but rarely progress to the invasive stage. On the other hand high-risk HPV types, such as HPV16 and 18 are strongly associated with high-grade SILs (HSILs, previously CIN Grades 2 and 3) and invasive carcinoma.

### ***1.2. Epidemiology of HPV and Cervical Cancer***

Cervical cancer is one of the most common cancers in women worldwide (16), second only to breast cancer. Almost half a million (493,243 in 2002) new cases are diagnosed each year with about a quarter of a million (273,505 in 2002) deaths per year (16). The incidence of cervical cancer in industrialized nations has been drastically reduced by cervical cytology screening programs. Thus, resulting in cervical cancer being seventh in cases diagnosed per year in the developed world (83,000) behind both cancers of the ovaries (97,000) and uterine corpi (136,000) (16). But more than 83% of cervical cancer deaths today occur in the developing world where resources for prevention and treatment programs are limited. Currently worldwide HPV prevalence is estimated to be about 25% (depending on diagnostic methodologies and geographic region) (17) with a very small proportion maintaining persistent HPV infection. Given these statistics, an effective and inexpensive vaccine is urgently needed to prevent and treat genital-tropic HPV infection worldwide.

## **2. HPV BIOLOGY**

### ***2.1. Structure***

The HPV genome is an 8 kbp circle of double-stranded, covalently closed, and histone bound DNA, which is maintained as an episome in infected cells during the productive virus life cycle. It encodes eight viral proteins across three frames (Fig. 1; see Color Plate 2, following p. 50) (18). The HPV genome is histone bound and surrounded by a 55–60 nm, nonenveloped icosahedral capsid (19) of  $T = 7$  symmetry, which contains the genetically unrelated major capsid protein L1 and the minor capsid protein L2 (Fig. 2; see Color Plate 3, following p. 50) (20). Each capsid contains 360 L1 monomers assembled into 72 pentameric structures termed capsomeres (20). It is likely that within the HPV virion, a single copy of L2 is positioned in the center of each capsomere (unpublished data) bound to L1 through two domains in L2 (21).

L1 and L2 are expressed late in the viral life cycle. The remaining six proteins are expressed earlier and are involved in viral transcription and replication (Table 2). The virus utilizes the host machinery for replication, with the exception of the viral helicase E1 and the E2 transcription factor. Initiation of replication is facilitated by interaction of E1 with E2. E2 exhibits sequence-specific binding with the viral origin of replication that contains multiple copies of its recognition motif. E2 also serves as a transcription

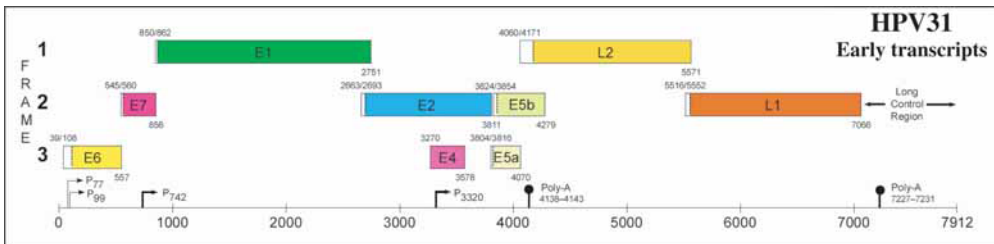

**Fig. 1 (Color Plate 2, following p. 50).** HPV genome organization. Schematic of the human papillomavirus 31 (HPV31) genome showing the arrangement of the major nonstructural and capsid genes along three frames. HPV31 mRNAs were investigated in CIN612 cells containing extrachromosomal HPV31. Four promoters were identified by primer extension, RNase protection, and nuclease *S*1 and *Exo*VII analyses (designated P<sub>77</sub>, P<sub>99</sub>, P<sub>742</sub>, and P<sub>3320</sub> based on their respective nucleotide start sites). Adapted from reference 18.

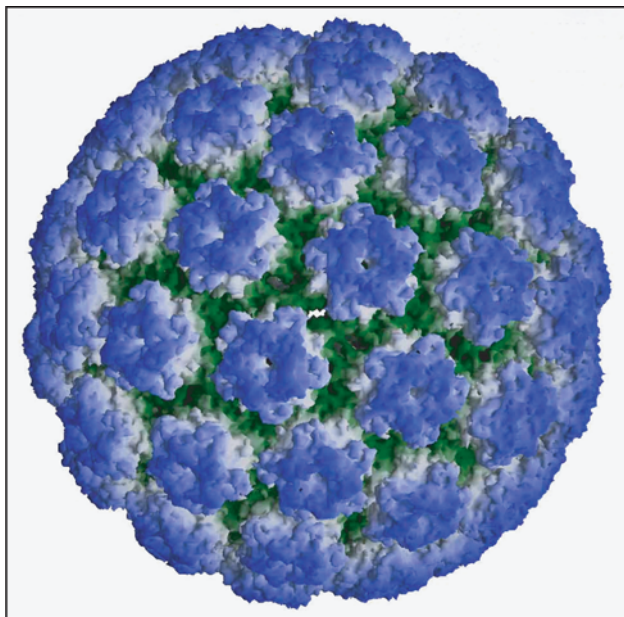

**Fig. 2 (Color Plate 3, following p. 50).** HPV structure. Model of the T = 7 icosahedral capsid (~60 nm in diameter) of the HPV16 virion exhibiting distinct fivefold axial symmetry surrounding a nucleohistone core. Adapted from reference 20.

factor and through its multiple spliced forms regulates viral gene expression. Furthermore, E2 ensures equitable distribution of the viral genome among daughter cells during cell division by tethering the viral episomes to mitotic chromosomes (22). As the virus replicates using the host machinery, it must counteract signals for terminal differentiation of the squamous epithelium and force the keratinocytes into S phase. This is achieved by three viral oncoproteins E5, E6, and E7. E5 promotes activation of the epidermal growth factor and platelet-derived growth factor growth factor receptors. E6 triggers degradation of the checkpoint protein p53 and other key molecules, such as PDZ domain proteins through ubiquitination. E7 targets the retinoblastoma protein (pRB)

**Table 2**  
**Papillomavirus Proteins**

<i>Viral protein</i>	<i>Gene product function</i>	<i>Role in HPV pathogenesis</i>
E1	Viral DNA replication	Initiates viral replication by binding AT-rich sequences at the viral origin near the start site of early transcription (104); sustains ATP-dependent helicase activity (105) to catalyze the unwinding of DNA and, additionally, binds DNA polymerase subunits (106) to recruit replication machinery to viral origins
E2	Transcription factor	Viral replication: binds to E1 in a heteromeric complex enhancing viral DNA replication by colocalization of E1 to the origin of replication (107) and abrogation of a mitotic checkpoint (108); tethering of the genome to mitotic chromosomes to ensure copies are included in both daughter cells (22)
E4	Egress of virions	Binds cytokeratins causing collapse of the cytoskeleton (109); associates with mitochondria and induces the detachment of mitochondria from microtubules leading to a severe reduction in mitochondrial membrane potential and induction of apoptosis (110)
E5	Oncoprotein	Induces cellular proliferation and hyperplasia in response to epidermal growth factor stimulation (111,112) through modulation of the epidermal growth factor-R (113); induces transformation of cells through interaction with platelet-derived growth factor-R (114)
E6	Oncoprotein	Targets p53 and discs large (Dlg) (115) for degradation, causing genomic instability (55); targets paxillin (116) and AP1 component of clathrin-coated vesicles (117) resulting in loss of cell adhesion to substrate and disruption of cytoskeleton and cellular traffic; activation of telomerase in infected cells, extending the life of epithelial cells for production of viral progeny (118); disrupts epithelial cell-dendritic cell interactions preventing the initiation of a cell-mediated immune response and promoting survival of the virus (119); inhibits the production and responsiveness of infected cells to type 1 interferons (120)

(Continued)

Table 2 (Continued)

<i>Viral protein</i>	<i>Gene product function</i>	<i>Role in HPV pathogenesis</i>
E7	Oncoprotein	Targets Rb (56) and p107 of the retinoblastoma family of tumor suppressors as well as several other cell-cycle proteins (59) leading to destabilization of cell-cycle control; inhibits the production and responsiveness of infected cells to type 1 interferons (38,39)
L1	Major capsid protein	Binds to heparan sulfate (121) and an laminin-5 (122) resulting in adsorption of the virion
L2	Minor capsid protein	Modulates infectivity by enhancing interaction between the N-terminal region and an unidentified cellular surface receptor facilitating HPV trafficking (24); may also play a major role in recruiting viral genomes for encapsidation by binding newly replicated viral DNA and subsequently recruiting L1 to create new virions (59)

pathway by releasing E2F. The viral oncogenes are involved in many other activities including blockade of apoptosis, activation of telomerase and myc expression, and the suppression of innate (e.g., interferon signaling) and adaptive (e.g., downregulation of major histocompatibility [MHC] class I) antiviral immune responses. The action of these oncogenes and the upregulation of E1 and E2 as the infected basal keratinocytes divide and leave the basement membrane and provide for overreplication of the viral genome. This overreplication increases the number of viral episomes from  $\sim 10^2$ /infected basal cell to  $10^4$ – $10^5$ /cell ready for packaging inside the capsid. HPV E1/E4 protein (henceforth referred to E4) is the most abundantly expressed viral protein in HPV-infected epithelia, formed by RNA splicing of sequences encoding the first five amino acids of E1 with the E4 open reading frame (23). E4 is expressed later than E1, E2, E5, E6, and E7, but earlier than the capsid proteins and is believed to facilitate viral message translation and breakdown of the keratin networks to allow for virus release. The minor capsid protein L2 is then expressed and targets to a subnuclear domain, ND-10. Therein it recruits the major capsid protein L1 and the histone-bound viral genome, which then assembles to form infectious virions (Fig. 3). There is no evidence for active virion export; rather, as the infected squames slough from the surface of the lesion, they are likely to disintegrate to release the virion particles. It is possible that the disintegration of the keratin networks by E4 facilitates dissemination of the virions, although this remains unproven.

## 2.2. Mechanism of Infection

The pathogenesis of cervical cancer is initiated by HPV infection of the cervical epithelium during sexual intercourse. Virions penetrate the epithelium through microabrasions and invade the basal cells of stratified epithelia of the uterine cervical transformation zone, establishing their genomes as a stable, low copy number of viral episomes (50–100 genomes per cell) in an initial burst of replication (Fig. 3; see Color

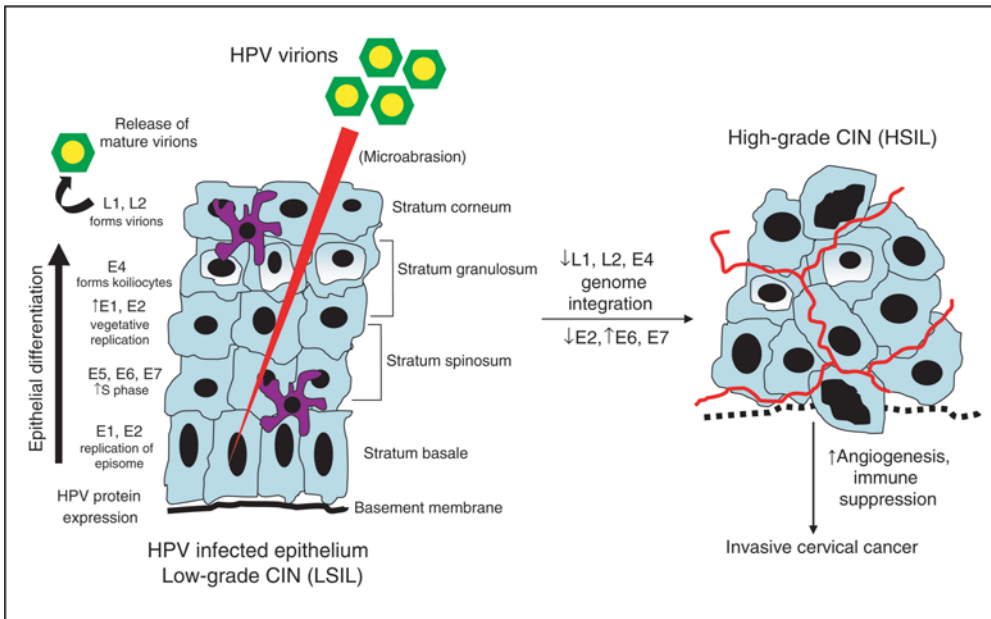

**Fig. 3 (Color Plate 4, following p. 50).** HPV life cycle. The pathogenesis of cervical cancer is initiated by HPV infection of the cervical epithelium during sexual intercourse. Virions penetrate the epithelium through microabrasions and invade the basal cells of stratified epithelia. Initiation of replication is facilitated by interaction of E1 with E2. Because the virus replicates using the host machinery, it must force the keratinocytes into S phase, despite signals for terminal differentiation of the squamous epithelium. This is achieved by three viral oncoproteins: E5, E6, and E7 (*see text*). The action of these oncogenes and the upregulation of E1 and E2 in the upper layers of the squamous epithelium, provide for overreplication of the viral genome. E4 is the most abundantly expressed viral protein in HPV-infected epithelia. E4 is expressed later than E1, E2, E5, E6, and E7, but earlier than the capsid proteins and is believed to facilitate viral message translation and breakdown of the keratin networks to allow for virus release. L1 and L2 are virus coat proteins and are expressed late in the viral life cycle. The remaining E proteins with the exception of E4 are present throughout the life cycle.

Plate 4, following p. 50). The first step of papillomavirus infection is believed to be binding of major capsid protein L1 with the cell surface without involvement of minor capsid protein L2 (24). The nature of the primary surface receptor is controversial. Although, both cell surface heparin sulphate glycosaminoglycans and  $\alpha_6$  integrin are sufficient to mediate interaction of particles with the cell surface, neither are necessary for infection in all cases (25). The minor capsid protein L2 plays a critical role in infection, but it functions after the initial binding of the virions with the cell surface (26). Its exact role is unclear, but L2 has been found to bind independently of L1 with the cell surface, to be processed by furin cleavage during infection (27) and to interact with syntaxin-18 (28) and actin (29) to facilitate passage of virions across the cytoplasm. The virions disintegrate after uptake, releasing the viral genome and L2 which enter into the nucleus together (30). L2 brings the viral genome to the ND-10 domain, which may facilitate early viral transcription and the initial burst of viral replication (31). The life cycle proceeds as described in the previous section.

### 2.3. Viral Clearance Vs Oncogenic Progression

Although, epidemiological studies show that more than 80% of HPV infections are benign and cleared within 12–18 months (32), a fraction of infections persists and can



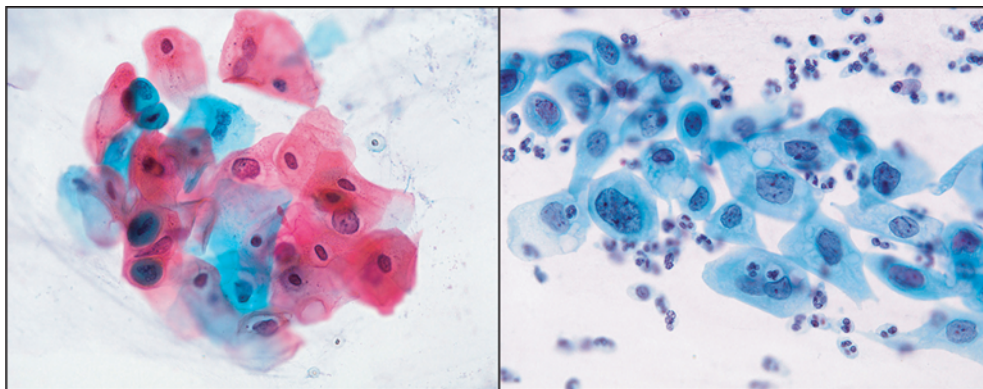

**Fig. 4 (Color Plate 5, following p. 50).** Examples of abnormal cervical cytopathology. **(A)** LSIL: A cluster of cells demonstrating the enlarged nuclei, hyperchromasia, smudgy chromatin pattern, even some koilocytosis (cytoplasmic clearing) typical of an LSIL lesion. **(B)** HSIL: A cluster of cells with markedly enlarged nuclei, hyperchromasia associated with coarse chromatin, and irregular nuclear membranes typical of an HSIL lesion (35).

initiate cellular transformation. It is the persistent infection with high-risk type HPVs that is necessary (but not sufficient) for the development of squamous carcinomas of the cervix and their precursor intraepithelial lesions (33,34).

Premalignant lesions of the cervix are characterized by abnormal cellular or epithelial architecture in the areas surrounding the junction between the squamous and columnar epithelium (the transformation zone) of the uterine cervix. Nuclear enlargement, hyperchromasia, binucleation, presence of abnormal mitoses, high nuclear to cytoplasm ratios, cytoplasmic clearing (koilocytosis reflecting E4 expression), abnormal epithelial differentiation, increased mitotic activity, and irregular cellular orientation are all typical features of dysplasia. Low-grade SIL (LSILs, previously CIN Grade 1) reflect the pathological changes observed in the cervical epithelium with HPV replication (Fig. 4A; *see* Color Plate 5, following p. 50) (35) and rarely progress to invasive cancer. At this stage, HPV DNA is still episomal. In women who are immunocompetent, many LSILs regress without medical intervention (33,36). In contrast, patients with HSIL, particularly those with immune deficiencies (e.g., HIV positive) or immune suppression (e.g., organ transplant patients), exhibit more persistent and severe HPV-related disease. Resolution of HPV infection involves specific immune responses, although this response is generally both weak and delayed. The poor immune recognition of HPV probably reflects its relatively “immune privileged” site of replication and the absence of a systemic infection (viremia). Furthermore, HPV neither kills keratinocytes nor appears to readily produce “danger signals” that induce inflammatory responses. Finally, the virus has several strategies to evade immunity. Papillomavirus oncoproteins have been implicated in the downregulation of MHC expression (37) and the production of type I interferons (38,39).

HSILs are associated with higher rates of progression to invasive cervical cancer and less frequent spontaneous regression (40) (Fig. 4B; *see* Color Plate 5, following p. 50) (35). Patients with low HPV viral loads are more likely to clear high-grade lesions as compared

with patients with high viral loads (40). Epidemiological evidence exists for several risk factors, which may promote the progression from infection and CIN to invasive cancer, including: human leukocyte antigen (HLA) haplotype (34,40), HPV-16 positive HSILs (40), tobacco (41), oral contraceptives (42,43), age, parity (44,45), and infection with *Chlamydia trachomatis* (for a more complete review, see ref. 34). The identification of potential risk factors for the progression of HPV infection to cancer remains especially important to consider in the context of the developing world, where cervical cancer is common, but few women have access to proper cytological screening resources.

The role of sex steroids in carcinogenesis has received special attention in the literature. Recent case–control studies of patients with histologically-confirmed invasive cervical carcinoma or carcinoma *in situ* (histological equivalent to a cytologically-identified precancerous SIL) have consistently found that long-term use of oral contraceptives increases risk of cervical carcinoma by up to fourfold in women who were positive for cervical HPV DNA (46–48). Other reproductive factors in the progression of HPV infection to cervical cancer have been studied, showing that high parity (defined as seven full-term pregnancies or more) increases the risk of squamous-cell carcinoma of the cervix among HPV-positive women by two to four times (as compared with women with one or two full-term pregnancies and nulliparous women, respectively) (49). Long-term oral contraceptive use and high parity was not associated with higher rates of HPV infection or HPV persistence. This suggests that the role for sex steroids in development of cervical cancer lies in carcinogenesis (progression of a persistent infection to cancer) rather than in increased risk of HPV infection (50,51). Whether it is progesterone, estrogen, or both hormones that contribute to cervical cancer etiology remains unclear.

The progression to invasive cervical cancer is associated with integration of the viral genome into the host genome. During the normal viral life cycle, E6 and E7 are maintained at low levels under transcriptional regulation by E2 (52–54). Integration typically disrupts the viral E2 gene, thereby negating E2-mediated repression of E6 and E7 and triggering their overexpression. Derepression of E6 and E7 exacerbates genomic instability through aberrant centrosomal duplication and suppression of cell-cycle checkpoints and activation of telomerase.

Ectopic expression of E6 and E7 of high-risk HPV types is sufficient for immortalization of human keratinocytes (Table 2) (8). One of the best-characterized functions of the E6 gene product is binding of the p53 tumor suppressor gene (55), promoting its degradation leading to subsequent genomic instability. Normally, p53 transcriptionally activates the expression of various regulators that induce cell-cycle arrest and apoptosis in response to chromosomal damage. Binding of high-risk HPV E6 facilitates the rapid turnover of p53, resulting in a reduction of the steady-state levels of p53, alleviating restrictions on cellular DNA synthesis and augmenting viral replication.

One of the best-characterized functions of the E7 gene product is formation of a complex with pRB (56), which when phosphorylated, limits cell proliferation and suppresses the neoplastic properties of various HPV types. E7 binding releases E2F and promotes entry into the cell cycle (57). However, it is important to note that both E6 and E7 are involved in numerous other activities that promote cellular transformation and prevent apoptosis, which are reviewed elsewhere (58–61).

### 3. VACCINATION AGAINST HUMAN PAPILLOMAVIRUS

Persistent infection with high-risk type HPV is a necessary cause of cervical cancer and therefore elimination of HPV infection will prevent this cancer (33,34). Furthermore, the majority of infections are cleared by the host's immune system suggesting the vaccination against this agent is feasible. Historically, vaccines have come to represent a highly cost-effective means to reduce the morbidity and mortality of infectious diseases. These facts have driven the rational development of preventative and therapeutic vaccination strategies based on the detailed understanding of the molecular biology of the HPV life cycle. Vaccination could be implemented to prevent infection (prophylactic) or eliminate infection (therapeutic), or optimally by combining both strategies in a preventive and therapeutic vaccine. The preventive vaccines typically elicit neutralizing antibody to interfere with HPV infection. The therapeutic vaccines would be likely to induce a virus-specific cellular immune response to trigger the regression of pre-existing lesions. It is also possible that therapeutic vaccines could be used "prophylactically," not to prevent the initial infection, but to clear the virus before clinically apparent lesions are established. The remainder of this chapter will discuss the recent developments in the clinical applications of HPV vaccines.

#### 3.1. *Prophylactic Vaccines*

The ultimate expression of medical success is prevention of a disease, and subsequently, its total eradication. It was not until the last case of endemic smallpox occurred in Somalia in 1977, with eradication of the disease declared shortly thereafter that vaccination was recognized as the means to eliminate diseases from the planet. The first mass vaccination strategy to prevent a cancer was the hepatitis B vaccine. Although, it has taken 20 years to demonstrate impact on hepatoma rates, the success of this preventive vaccine is now clear. Because the etiology of cervical cancer is infectious in nature, interfering with HPV infection with a prophylactic vaccine should theoretically prevent development of the disease and potentially achieve total eradication of cervical cancer and other HPV-related cancers. However, prophylaxis does not benefit those with pre-existing disease. This is a significant issue because of the considerable burden of HPV infection worldwide. Furthermore, purely prophylactic vaccines will not impact cervical cancer rates for approx 10–20 years from the introduction of a mass vaccination program because of the existing infections and the slow process of carcinogenesis.

As the target population of a preventative HPV vaccine will most likely be healthy adolescents who are not yet sexually active, the primary concern of prophylactic vaccine development is safety. The use of a live attenuated virus vaccine has been shown to be safe and effective in the prevention of diseases, such as influenza, measles, mumps, and rubella. Yet, the difficulty of propagating large amounts of HPV combined with necessity of viral oncoproteins in the HPV replication process, has made this strategy impractical. Although, vaccines targeting the early viral antigens could prevent establishment of infection, current strategies for safe and effective prophylactic vaccination have focussed on inducing neutralizing antibodies against the major and/or minor capsid proteins.

##### 3.1.1. L1-BASED VACCINES

When the major capsid protein L1 is overexpressed in various cell types, it spontaneously assembles into virus-like particles (VLPs) (62–64). Although, the viral genome

and the minor capsid protein L2 are absent, L1 VLPs possess similar morphology and antigenicity to natural virions. Parenteral vaccination with papillomavirus L1 VLPs has been shown to induce high titers of serum neutralizing antibodies in animal models. Importantly, intramuscular vaccination with HPV L1 VLPs in women has been shown to be both immunogenic and safe in early phase clinical trials.

HPV is transmitted through sexual intercourse, and animal models of papillomavirus infection do not mimic sexual transmission. Therefore, there has been great concern that animal models with cutaneous or oral papillomaviruses would not be useful in vaccine development for genital HPVs, and that successful vaccine preclinical studies might not be predictive in patients. Because HPV infection is limited to the epithelium and local and therefore does not produce viremia, another significant concern in the field has been that an effective prophylactic HPV vaccine might require the local generation of virus-specific immune responses. Although, human studies confirm that high titers of specific antibodies are present in cervical secretions of women receiving intramuscular HPV16 L1 VLP immunization (65,66). In this case, transfer of serum IgG to the genital tract occurs through the process of transudation or exudation at the site of microtrauma rather than local synthesis of specific antibody. Transudation results in a diffusion gradient and thus significantly lowers titers of antibodies as compared with the serum concentration. Furthermore, the efficiency of transudation and therefore titers of antibody at the mucosal surface varies across the menstrual cycle, raising the possibility of protection during only certain phases.

Despite these concerns, a landmark clinical trial of 2392 women demonstrated that HPV-16 L1 VLPs are capable of protecting women from HPV infection and HPV-associated CIN (11). In this study, the incidence of persistent HPV-16 infection was 3.8 per 100 woman-years at risk in the placebo group and 0 per 100 woman-years at risk in the vaccine group. In short, the L1 VLP vaccine was 100% effective (confidence interval = 90–100%) at preventing persistent HPV-16 infection in the population of females tested and during this relatively short period of approximately one and a half years. This protection has been most recently extended to three and a half years (67).

Prevention of cervical cancer is not a reasonable efficacy end point for these preventive vaccine studies. Rather, as the precursor of cervical cancer, protection against incident HPV-related CIN is an appropriate measure of vaccine efficacy. Importantly, new HPV16-related CIN only occurred among the placebo recipients, although the numbers were small in this study (11). This study suggests that VLP vaccination can protect throughout the menstrual cycle against HPV infection. It should be noted that a contribution of L1-specific cellular immunity to protection has not been ruled out. The longevity of protection is currently under investigation and is likely to be influenced by the adjuvants used with the VLPs. More clinical trials of VLP vaccines are currently under way (summarized in Table 4), including a large, randomized, double-blind, placebo-controlled trial of HPV16 and HPV18 L1 VLPs in 21,000 Costa Rican women (68) to investigate the long-term protective efficacy of the VLP vaccination. Although human and nonhuman primate studies suggest that these antibodies are quite durable (33,69), tracking the level of the antibodies in vaccines and breakthrough in infections in the long-term is an important area of ongoing study. In particular, it will be important to define the threshold protective titer of neutralizing antibodies to allow monitoring of successful vaccination, and decisions on the timing for booster vaccinations.

The results from the VLP clinical trials are promising, but further work is required. For example, Koutsky and colleagues recently reported that vaccination of uninfected women with VLPs comprising HPV16 L1 was 100% effective in preventing acquisition of HPV16 infection and HPV16-related CIN (11). The incidence of other HPV-related cervical neoplasia was equal in placebo and vaccine groups (Table 3). This suggests that HPV L1 VLP vaccines may only provide protection against infection by the homologous papillomavirus type and this is consistent with the type-restricted specificity of the neutralizing antibodies that mediate protection. However, recent reports from GSK's VLP vaccine trials suggest the possibility of partial protection against very closely related types, for example, HPV18 and HPV45 (70). Interestingly, this is consistent with earlier in vitro neutralization studies, further supporting the importance of neutralizing antibodies in protection and the validity of this approach to monitor immunization (71). However, if immunity is very type-restricted, then this renders comprehensive vaccination against cervical cancer with L1 VLPs extremely difficult and increases the cost and complexity of vaccine development. For example, a completely effective and type-specific HPV prophylactic vaccine would require 11 distinct types of VLPs to prevent 95% of cervical cancer (Fig. 5) (72). Current formulations of both L1 VLP vaccines in phase III clinical trials run by Merck and GSK contain only two oncogenic HPV genotypes, HPV16 and HPV18, which together account for only 70% of cervical cancers (73,74). Merck has also chosen to include HPV6 and HPV11 L1 VLPs in their vaccine "Uardasil," but these will only protect against benign genital warts (74). The current formulation of HPV VLP vaccine protects against the most prevalent, but not all oncogenic HPV types, and this will have important implications for screening programs. The Pap screening program in the US costs in excess of 6 billion USD per year, but cessation of this program would likely require a vaccine that protects against most if not all oncogenic HPV types (Fig. 5).

### 3.1.2. L2-BASED VACCINES

Although, major capsid protein L1 is the immunodominant antigen in the generation of neutralizing antibodies in vivo (75), minor capsid protein L2 has also arisen as a possible target for vaccine development (Table 4). Preclinical studies suggest that L1 VLP-based vaccines elicit a stronger immunogenic response than L2-based vaccines, but unlike L1 VLP-based vaccines, vaccination with HPV L2 induces antibodies that cross-neutralize diverse HPV genotypes (75,76). Vaccination with L2 peptides in animal models protects from experimental challenge by the homologous type papillomavirus. This protection is mediated by neutralizing antibodies (76). L2 is thus considered a promising candidate for a single antigen capable of eliciting a broadly neutralizing antibody response, which is protective against all oncogenic HPV infections and related disease. Although, these L2 vaccines are promising, the low titers of neutralizing antibodies (and especially cross-neutralizing antibodies) induced by L2 as compared with L1 VLP vaccines suggest that these L2 vaccines thus far are not optimal. Importantly, the ability of L2 vaccination to provide cross-type *protection* must also be demonstrated. In a recent data (Neil Christensen Richard Rodon, unpublished data) it has been found that vaccination with HPV16 L2 11–200 protects rabbits from experimental challenge with either CRPV or ROPV, two viruses that are evolutionarily highly divergent from HPV16 (77). If this is borne out in patients and the relatively low

**Table 3**  
**Summary of the Data From Phase III Trials of an HPV16 L1 VLP Vaccine**

	Vaccine	Placebo
<i>1.5 years<sup>a</sup></i>		
Subjects	768	765
Persistent 16	0	41
CIN 1 16 <sup>+</sup>	0	5
CIN 2/3 16 <sup>+</sup>	0	4
CIN non16	22	22
<i>3.5 years<sup>b</sup></i>		
Subjects	1193	1198
Persistent 16	0	87
CIN 1 16 <sup>+</sup>	0	12
CIN 2/3 16 <sup>+</sup>	0	12
16 <sup>-</sup> CIN 1	8	4
16 <sup>-</sup> CIN 2/3	34	23

In this ongoing phase III prophylactic vaccination trial of HPV16 L1 VLPs, women without evidence of HPV16 infection were vaccinated three times with HPV16 L1 VLPs or placebo and followed for new persistent HPV16 infection or development of CIN (11,67).

<sup>a</sup>During the first 1.5 years after immunization, vaccination provided 100% (95% confidence interval: 90–100;  $p < 0.0001$ ) protection against acquisition of persistent HPV16 infection. Although, 41 incident persistent HPV16 infections and 9 HPV16 DNA positive CIN (high- and low-grade) occurred in the placebo recipients, 22 cases of non-HPV16 CIN occurred in both placebo and vaccine recipients.

<sup>b</sup>After 3.5 years, vaccine efficacy remained high. Although, 87 incident persistent HPV16 infections and 24 HPV16 DNA positive CIN (high- and low-grade) occurred in the placebo recipients, 42 cases of non-HPV16 CIN occurred in vaccine recipients (vs 27 cases in placebo recipients).

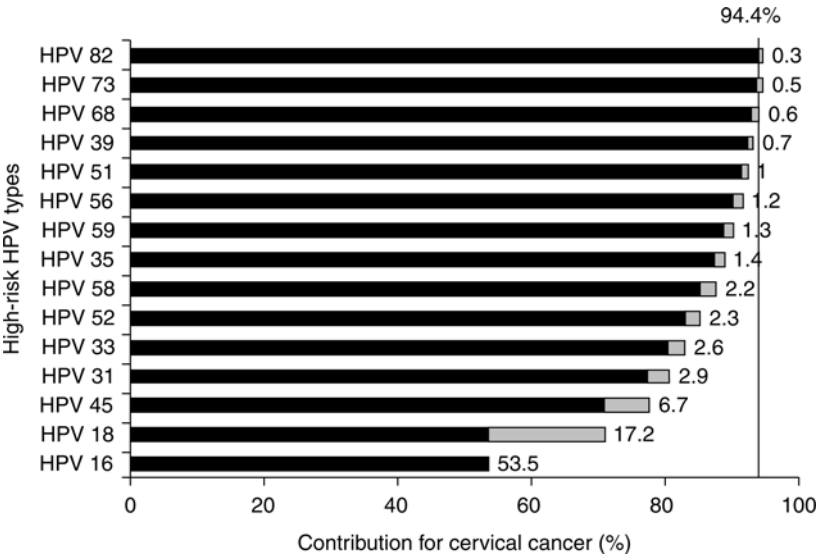

**Fig. 5.** Addition of L1 VLP from HPV genotypes in addition to HPV16 will have limited benefit. Percent of cervical cancer cases attributed to the most frequent HPV genotypes in all world regions combined (women 15 years of age and older) are given in black bars. Cumulative frequencies in order from the most prevalent types is shown in gray. A completely effective and type specific HPV prophylactic vaccine would require 11 distinct formulations to prevent ~95% of cervical cancer (72).

immunogenicity of L2 can be overcome with suitable adjuvants, protection induced by vaccination with L2 could potentially be very broad. The extent of cross-neutralization by an L2 vaccine might be enhanced by the generation of a synthetic consensus L2 antigen. The breadth of the cross-neutralizing activity of L2 antisera suggests the possibility that this vaccine antigen might also prevent transmission of HPV types that cause benign genital warts, and possibly even plantar/planar or Epidermodysplasia verruciformis type warts.

In contrast, the L1 VLP vaccine, especially in a highly multivalent form, is likely to be expensive to produce, as the L1 is expressed in Sf9 insect cells (by GSK) or yeast (by Merck). An added benefit to the L2-based vaccine is that production of a single L2-based antigen produced in *Escherichia coli* is likely to be less expensive to produce. It should be noted that L1 capsomers can be produced in *E. coli* (78). The L1 capsomer vaccine exhibits good stability and induces protection in the canine model (79), albeit likely type specific as for the L1 VLP vaccines. Another possible approach is the use of L1-expressing DNA vaccines that might be more stable, easier to produce and multiplex at low cost. The issue of cost per dose is especially important as more than 83% of cervical cancer deaths today occur in the developing world (16) that lack the infrastructure for Pap screening and lesion ablation. Furthermore, all of these vaccines require a cold chain, which is likely to be problematic in rural, hard to access areas. They also require multiple immunizations with needles. Perhaps the use of a live vector to deliver the HPV capsid antigens, for example, nonpathogenic *Salmonella* or VSV, could overcome many of these issues, although safety would be a significant concern. Future efforts in second generation HPV vaccines should address these issues.

### 3.2. Therapeutic Vaccines

Infected basal epithelial cells and cervical cancer cells do not express detectable levels of capsid antigen. Thus, although L1 VLP and L2 vaccines may be protective, they are likely to be ineffective in the elimination of pre-existing infection and HPV-related disease. Currently there are more than 100 million infected women, 5% of whom are estimated to have persistent disease (80). Moreover, it is still possible that some viruses will breakthrough neutralizing antibodies induced by prophylactic vaccination and establish new infection. This is especially important because those VLP vaccines in the clinic are likely to protect against a limited number of HPV types. Given these potential shortcomings, additional measures to deal with established HPV infection and HPV-associated diseases are currently under investigation.

Neutralizing antibodies are found in patients with both regressing and progressing lesions suggesting that these antibodies do not play a role in the regression process (81). Regression of low-grade CIN (Grade I) has been associated with the presence of neutralizing antibodies, but humoral immunodeficiency does not increase susceptibility to development of HPV lesions. In contrast, patients with altered CD4 T cell function, such as organ transplant patients (82) and patients with HIV (83–85), have an increased prevalence of HPV infection and more severe HPV-related disease. Preclinical studies with agents that suppress cellular immunity have reduced rates of papilloma regression and more aggressive disease. Furthermore, infiltrating CD4+ and CD8+ T-cells are often observed in spontaneously regressing HPV warts whereas T cells are rarely seen in non-regressing warts (86). These clinical observations provide evidence that cell-mediated

**Table 4**  
**Comparison of Prophylactic HPV Vaccine Antigens**

<i>Antigen</i>	<i>Approach</i>	<i>Advantages</i>	<i>Disadvantages</i>	<i>Clinical trial results</i>
L1	VLP	Safe in humans Immunogenic (elicits high titers of neutralizing antibodies, which have been demonstrated in the cervical mucosa) Effective (prevents type-specific HPV infection and neoplastic sequelae) Adjuvant not required Available (Gardasil®)	Expensive to produce Requires cold chain Limited cross-neutralizing power (requires multivalent vaccines to effectively protect against multiple HPV types)	HPV16 L1VLP: randomized, placebo-controlled trials in healthy volunteers (11,67,123–125) HPV18 L1VLP: randomized, placebo-controlled trials in healthy young women (126) HPV16,18 bivalent L1 VLP: randomized placebo-controlled trials in healthy young women (73) HPV6,11,16,18 quadrivalent L1 VLP: randomized placebo-controlled trials in healthy young women (74)
L2	Peptide	Safe in humans Inexpensive to produce Easy to produce and store Cross-neutralizing against multiple HPV types (potential to develop a monovalent vaccine)	Poorly immunogenic (elicits low titers of neutralizing antibodies) Adjuvant required Promise of availability is not in the near future (candidate vaccines are still in preclinical development)	HPV16 L2 aa108–120: randomized, placebo-controlled trial in healthy volunteers (127) HPV16 L2 E7E6 trials (100)



immunity and nonhumoral immunity are important in the control of established HPV infection and HPV-related lesions.

In order to prevent the development of lesions, eliminate existing lesions, or even eliminate malignancies, a therapeutic vaccine should target HPV antigens that are continuously expressed in the infected cells and cancer cells. HPV encodes eight papillomavirus genes (*see* Table 1) that are potential “nonself” targets for a therapeutic vaccine. Infected basal epithelial cells usually do not express E4, L1, or L2 proteins at detectable levels. Additionally, the E1, L1, and L2 genes and especially the E2 gene are frequently lost in HPV-associated malignancies during integration. Indeed these genes are dispensable for transformation, and loss of E2 is in fact believed to enhance this process. E5 is not considered an optimal target because it is not required for transformation. It is also poorly immunogenic, probably reflecting its location predominantly within membranes. In contrast, the remaining viral oncoproteins are potential target antigens as they are expressed throughout the viral life cycle and help to regulate progression of the disease. E6 and E7 are critical for HPV replication and cervical epithelial transformation, and are expressed throughout the viral life cycle. As described earlier, because E2, a negative regulator of E6 and E7, is often deleted during the HPV transformation process, E6 and E7 genes are further upregulated in cervical cancer cells. Thus, E6 and E7 are important targets for HPV therapeutic vaccines because they are not expressed in normal cells, but are expressed in all HPV infected cells and they cannot be lost by the tumor as this results in apoptosis. And, whereas E2 is a poor target for immunotherapy of cervical cancer, E1 and E2 represent potential targets for induction of papilloma and CIN regression.

Live-vector vaccines, peptide or protein vaccines, nucleic acid vaccines, cell-based vaccines, and combined approach vaccines have all been tested in the development of HPV therapeutic vaccines both preclinically and now, more frequently in patients. However, despite many successes in curing mice of transplantable tumor models, human trials of many therapeutic vaccines have provided little or no benefit to patients with HPV malignancies. Thus the focus is on the findings in patients to form future improvements in vaccine strategies, combination of treatments, better animal models, and designing immunological assays that better correlate with clinical outcome. Table 5 is a summary of the advantages and disadvantages of the HPV therapeutic strategies and the progress these approaches have made in clinical trials.

The most extensive studies have been performed with peptide-based, viral-vector and naked DNA vaccines. Peptide-based therapeutic vaccines are stable, easily produced, and safe. Unfortunately, they are also immunogenically weak and therefore require adjuvants; and with respect to cell-mediated immunity, these vaccines are also MHC-specific. Synthetic peptides representing two HPV16 E7-encoded, HLA-A0201-restricted cytotoxic T lymphocyte epitopes have been studied in patients with recurrent or residual cervical carcinoma refractory to conventional treatment (87–89). Additionally, a vaccine consisting of a 9-amino acid peptide from HPV-16 E7 amino acids 12–20 was tested in women with high-grade cervical or vulvar intraepithelial neoplasia who were positive for HPV-16 and were HLA-A2 (90). These HPV peptide vaccines have been shown to be both safe and well tolerated in humans. However, HPV-specific immune responses generated by these vaccines have been weak and correlated poorly with the few clinical responses. A subgroup of patients vaccinated with these peptide

epitopes do show measured regression of lesions and even clearance of dysplasia. However, neither peptide-specific proliferative cytotoxic T-lymphocyte (CTL) responses nor lesion regression are consistently detected.

The live vector vaccines, especially those that are capable of replication in the host, are generally highly immunogenic and can induce strong immune responses. However, there are significant safety concerns, particularly in cancer patients with weakened immune systems. The prevalence of pre-existing vector immunity that may decrease the effectiveness of the vaccine and inhibit repeated vaccination is another issue with this vaccination strategy that must be considered. Additionally, vector antigens may become immunodominant on the HPV antigen carried on the vector, thus interfering with the formation of an efficacious anti-HPV immune response. Some live vector vaccines have passed preclinical evaluations and proceeded into clinical trials. For example, a recombinant vaccinia virus encoding HPV-16 and HPV-18 E6/E7 (called TA-HPV) was tested in clinical trials. Importantly, TA-HPV was well tolerated and T-cell immune responses were observed after vaccination in some patients with high-grade CIN, early invasive cervical cancer, and even advanced cervical cancer (91–93). The vaccine was also given to patients with HPV-associated vulvar or vaginal intraepithelial neoplasia with specific immune responses observed (94,95). In a study conducted by Baldwin and colleagues, five out of 12 patients had at least a 50% reduction in lesion diameter after 24 weeks, and one patient showed complete regression of lesion after vaccination (94). TA-HPV has also been used in conjunction with the fusion protein TA-CIN using a prime-boost strategy (*see* Table 5). Another recombinant vaccinia virus encoding E2 (called MVA E2) has been tested in patients with CIN. Although, utilized as a genetic therapy, the vaccine might potentially generate HPV-reactive E2-specific immune responses (96).

DNA vaccines, most commonly in the form of naked DNA expression plasmids, have several beneficial features for HPV therapeutic vaccine development. DNA vectors are easily produced and can be engineered to express tumor antigenic peptides or proteins. The stability and purity of DNA vaccines are even higher than peptide or protein vaccines. DNA vaccines also have the ability to produce antigenic proteins and peptides in antigen-presenting cells during an extended period. Thus, the amount of antigen delivered to the immune system is potentially higher than for peptide and protein vaccines. This is also an issue when expressing viral oncogenes, and therefore E6 and E7 containing inactivating mutations are frequently used. Using DNA vaccines to express proteins, thus allowing the cell to generate its own peptide–MHC complex, bypasses the MHC restriction whereas maintaining higher CTL responses than current protein vaccines in preclinical studies. DNA vaccines can also be repeatedly applied to the same patient safely and effectively, unlike vaccines, which utilize a live vector. But like peptide vaccines, DNA vaccines are limited by their low immunogenicity. This limited immunogenicity may be enhanced by expression of only the relevant epitopes to facilitate antigen processing and presentation.

Some DNA-based vaccines have passed preclinical evaluations and proceeded into clinical trials. A clinical trial in patients with high-grade anal intraepithelial lesions (97) and another in CIN-2/3 patients (98), tested a plasmid DNA vaccine, ZYC101 (ZYCOS Inc), which encodes multiple HLA-A2-restricted epitopes derived from the HPV-16 E7 protein. Subjects were shown to tolerate the vaccine well. Similar to many

**Table 5**  
**Characteristics of Therapeutic HPV Vaccine Approaches**

<i>Approach</i>	<i>Advantages</i>	<i>Disadvantages</i>	<i>Clinical trials</i>
Peptide-based	<p>Stable</p> <p>Easy to produce</p> <p>Safe</p> <p>Can incorporate multiple epitopes</p> <p>Can enhance peptides for MHC binding</p>	<p>Weakly immunogenic</p> <p>Must determine epitopes</p> <p>HLA restriction</p>	<p>Study of toxicity and anti-tumor immune responses in patients with recurrent or residual cervical carcinoma refractory to conventional treatment, receiving vaccinations with synthetic peptides representing two HPV 16 E7-encoded, HLA-A*0201-restricted cytotoxic T lymphocyte epitopes and a pan-HLA-DR-binding T-helper epitope, PADRE, in adjuvant (87,88)</p> <p>Study of a vaccine consisting of a 9-amino acid peptide from amino acids 12–20 encoded by the E7 gene emulsified with incomplete Freund’s adjuvant in women with high-grade cervical or vulvar intraepithelial neoplasia who were positive for HPV-16 and were HLA-A2 positive (90)</p> <p>Study of HLA-A*0201-restricted, HPV-16 E7 lipopeptide vaccine in eliciting cellular immune responses in women with refractory cervical cancer (89)</p>
Protein-based	<p>Easy to produce</p> <p>Multiple known adjuvants</p> <p>No HLA restriction</p> <p>Can produce fusion proteins for enhanced immunogenicity</p>	<p>Weakly immunogenic</p> <p>Usually better induction of antibody response than CTL response</p>	<p>Study of immunogenicity of PD-E7/AS02, an HPV-16 E7 protein-based vaccine linked to the first 108 amino acids of Haemophilus influenzae protein D, formulated in the GlaxoSmithKline Biologicals adjuvant AS02B, in women with oncogenic HPV-positive CIN (128)</p>

Vector-based: Viral	<p>Highly immunogenic Can take advantage of the different immunological properties of viruses Wide variety of vectors available (i.e., vaccinia, adv, AAV, alphavirus) Can be engineered to express cytokines of other stimulatory molecules</p>	<p>Risk of toxicity when using live viruses Potential pre-existing immunity Inhibited repeat immunization Immunodominance of viral vector antigens on HPV tumor antigens</p>	<p>Study in patients with early-stage cervical cancer (93), late stage cervical cancer (92) and HPV-positive vaginal or vulvar intraepithelial neoplasia (94,95) to assess the safety and immunological effects of vaccination with <i>TA-HPV</i>, a live recombinant vaccinia virus expressing modified forms of the HPV-16 and -18 E6 and E7 proteins Study in patients with CIN (Grades I–III) to assess the safety and immunogenicity of intrauterine immunization with <i>MVA E2 recombinant vaccinia virus</i> vaccine (96)</p>
Vector-based: Bacterial	<p>Highly immunogenic Can deliver either engineered plasmids of HPV tumor proteins to APCs Wide variety of vectors are available (i.e., <i>Listeria</i>, <i>Salmonella</i>, BCG, <i>Lactococcus</i>) Easy to produce, store, and transport Versatility in ability to add targeting and/or costimulatory genes Multiple immunizations possible</p>	<p>Risk of toxicity when using live bacteria Potential pre-existing immunity Inhibited repeat immunization</p>	<p>Study in subjects with anal HPV-16 infection (97) and high-grade CIN (98) evaluating the safety and immunogenicity of <i>ZYC101</i>, an encapsulated plasmid DNA vaccine encoding multiple <i>HLA-A2</i>-restricted epitopes derived from the HPV-16 E7 protein</p>
DNA			

(Continued)

**Table 5 (Continued)**

<i>Approach</i>	<i>Advantages</i>	<i>Disadvantages</i>	<i>Clinical trials</i>
RNA	<p>Wide variety of modes of administration (i.e., direct injection, gene gun, intranasal, and biojector)</p> <p>Sustained expression of antigen on MHC-peptide complexes (vs peptide/protein vaccines)</p> <p>Noninfectious and transient (no risks of chromosomal integration or cellular transformation)</p> <p>Multiple immunizations possible</p> <p>RNA replicons replicate within the cell to enhance antigen expression</p> <p>Multiple vectors available</p>	<p>Unstable to store and handle</p> <p>Cumbersome to prepare</p> <p>Difficult to produce in large quantities</p>	<p>Study to assess the safety and efficacy of <i>ZYC101a</i>, an encapsulated plasmid DNA vaccine encoding fragments derived from the E6 and E7 proteins of HPV-16 and -18, in women with high-grade CIN (Grade II or III) (99)</p>
Dendritic cell-based	<p>Highly immunogenic (uses the most potent Antigen-presenting cell [APC])</p> <p>Generation of large quantities of DCs possible</p> <p>Multiple methods of antigen loading available</p>	<p>Labor-intensive, costly, <i>ex vivo</i>, individualized cell processing</p> <p>Variable quality control and lack of standard criteria for quality of vaccines</p> <p>Do not necessarily home to draining lymph nodes</p>	<p>Study of HPV-16 and -18 E7 antigen-loaded autologous dendritic cell vaccination in a small series of cervical cancer patients with recurrent disease refractory to standard treatment modalities (129,130)</p>

<p>Potency can be enhanced by gene transduction or cytokine treatment</p> <p>Useful if tumor antigen is unknown</p> <p>Potency can be enhanced by gene transduction or cytokine treatment</p> <p>Likely to express relevant tumor antigens</p>	<p>Tolerization by immature DCs possible</p>
<p>Useful if tumor antigen is unknown</p>	<p>Safety concerns regarding injection of tumor cells into patients</p>
<p>Potency can be enhanced by gene transduction or cytokine treatment</p>	<p>Labor intensive production</p>
<p>Likely to express relevant tumor antigens</p>	<p>Weak antigen presentation by tumor cells</p> <p>Requires availability of tumor cell lines or autologous tumor cells</p>

of the other therapeutic vaccines under clinical evaluation, the immune and clinical responses to vaccination have not been consistent. The immune response to the peptide epitopes encoded within the DNA vaccine was increased in 10 of the 12 individuals with anal dysplasia (97). Five out of 15 women with CIN-2/3 had complete histological responses and 11 out of 15 women with CIN-2/3 had human papillomavirus-specific T-cell responses (98). The next generation ZYC-101 vaccine, ZYC-101a (ZYCOS Inc), contains a plasmid DNA encoding both HPV-16 and HPV-18 E6 and E7 epitopes. A recent phase II trial demonstrates that a prospectively defined subgroup of younger women have a significantly higher rate of disease resolution when treated with ZYC-101a than when administered placebo (99). However, when comparing the effect of placebo and ZYC-101a in the whole population studied, no significant difference was observed.

The limited immunogenicity of DNA vaccines may potentially be enhanced by fusion of the antigen with molecules that improve antigen processing and promote immune recognition. For example, clinical trials of HPV16 E7 expressed with a signal sequence and fused to a heat shock protein are ongoing at Johns Hopkins University. In preclinical studies the signal sequence enhances antigen processing of the E7 and its release from the cell whereas heat shock protein binds with and activates dendritic cells. Fusion of E7 to calreticulin also produces similar phenomena and may provide antiangiogenic activities.

### ***3.3. Combination Approaches***

The ideal HPV vaccine would induce both humoral and cell-mediated immunity to prevent new infections as well as eliminating established infection or HPV-related disease. One such strategy has involved the fusion of HPV capsid proteins and HPV early proteins, for example the fusion of L1 with E7 to form chimeric VLPs. An early trial initiated by Medigene with chimeric L1-E7 VLPs demonstrated immunogenicity and safety, but insufficient clinical efficacy in CIN patients for further development by this company. Another potential chimeric/therapeutic vaccine is a fusion of HPV-16 L2 with E6 and E7 (called TA-CIN by Cantab/Xenova Pharmaceuticals). TA-CIN was also shown to be safe and immunogenic in several clinical trials. Vaccination with TA-CIN induces HPV16 and HPV18-specific neutralizing antibodies, even in the absence of adjuvant unpublished observations. Despite the absence of an adjuvant, specific antibody and T-cell proliferation responses were observed in the majority of patients receiving the highest dose (100). In order to further enhance vaccine potency, a "prime-boost" strategy, combining TA-CIN and TA-HPV (vaccinia virus encoding HPV 16/18 E6E7) vaccinations, was tested in 10 women with HPV 16-positive high-grade vulvar intraepithelial neoplasia. They first received a TA-HPV vaccine and then were boosted three times with TA-CIN. HPV 16-specific proliferative T-cell and/or serological responses were observed in nine of the women, and three women showed lesion shrinkage or symptom relief. However, no direct correlation between clinical and immunological responses was observed. Importantly, all of these studies were performed using protein antigens without adjuvant and may therefore not be optimal.

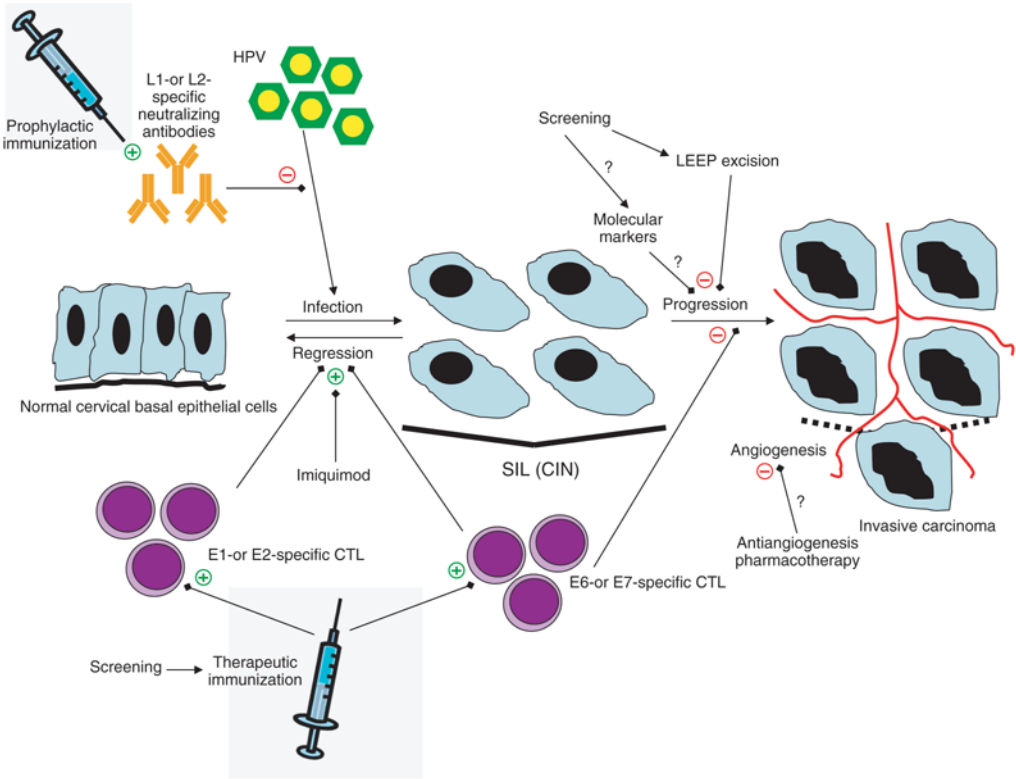

Fig. 6 (Color Plate 6, following p. 50). Summary of strategies to prevent and treat cervical cancer.

#### 4. CONCLUSIONS

Great progress has been made in the development of prophylactic vaccines against HPV, such that cervical cancer could very well be the second cancer to be prevented through mass vaccination (Fig. 6; *see* Color Plate 6, following p. 50). Important lessons can be learned from these successes and from the slower progress in the development of therapeutic HPV vaccines. Research into the etiology of cervical cancer and the biology of HPV provided critical insights regarding the relevant target antigens for effective vaccination. The importance of relevant and facile animal models is demonstrated both by the success of preventive vaccine development using animal papillomavirus challenge models, and the issues in using tumor transplant models in mice for therapeutic vaccine development. Similarly, the development of relevant immunological assays is also critical to the rational development of vaccines, as epitomized by the measurement of protective antibodies by VLP ELISA or in vitro neutralization assays. Unfortunately, the assays most relevant for therapeutic responses lag behind and correlate poorly thus far with clinical response. Nonetheless, each year sees remarkable advances in the field of immunology. With an improved understanding of the mechanisms governing tumor regression or tolerance, we are hopeful that these issues can be overcome.

The success of the VLP vaccine trials has catalyzed the development of second generation preventive vaccines. Clearly, additional HPV VLP types need to be included to



provide broader protection and eventually render Pap and HPV screening programs unnecessary. The development of both broad HPV immunity and comprehensive vaccine programs are critical to the eventual elimination of cervical cancer. In addition to the highly multivalent HPV VLP vaccines, the potential for broad cross-protection by L2-based vaccines should be further explored. The second generation HPV preventive vaccines should build on the safety and efficacy of the L1 VLPs to provide broadly-protective, inexpensive, stable, and easily administered formulations. Such vaccine properties and support for comprehensive vaccine programs are critical to adequately address the global burden of HPV infection and cervical cancer.

The large existing burden of HPV disease and the ~20 year delayed impact of preventive vaccination on cervical cancer rates demonstrates the need for continued efforts to develop therapeutic HPV vaccines (Fig. 6; see Color Plate 6, following p. 50). The clearance of established infection or disease is clearly a more difficult problem than prevention of new infections. One of the major obstacles is an incomplete understanding of why most HPV-positive lesions naturally regress, whereas others do not. New research suggests the importance of tumor tolerance and immune suppression in the tumor environment. In addition, the virus and the cancer cells utilize multiple molecular tricks to escape immune surveillance. However, recent advances in the understanding of antigen processing, innate recognition (e.g., toll-like receptors), and tolerogenic mechanisms (e.g., NO, arginase) suggest several avenues to break tolerance and improve the effectiveness of virus-specific cytotoxic T-cell responses. Given these issues and ongoing screening programs, it may be appropriate to focus on early therapeutic vaccine efforts in patients with LSIL, for whom tolerance is less likely to be an issue (as suggested by high rates of spontaneous regression). Finally, technological improvements in vaccine delivery vehicles and immunological assays are important and should continue. Clearly, cervical cancer represents an important model system to develop immunotherapies for other cancers with less well-defined etiologies and rejection antigens. Research into HPV therapeutic vaccines shows great promise and is likely to have broad impact.

## REFERENCES

1. zur Hausen H, Meinhof W, Scheiber W, Bornkamm GW. Attempts to detect virus-specific DNA in human tumors. I. Nucleic acid hybridizations with complementary RNA of human wart virus. *Int J Cancer* 1974; 13(5): 650–656.
2. Gissmann L, Boshart M, Durst M, Ikenberg H, Wagner D, zur Hausen H. Presence of human papillomavirus in genital tumors. *J Invest Dermatol* 1984; 83(Suppl 1): 26S–28S.
3. Walboomers JM, Jacobs MV, Manos MM, et al. Human papillomavirus is a necessary cause of invasive cervical cancer worldwide. *J Pathol* 1999; 189(1): 12–19.
4. Schwarz E, Freese UK, Gissmann L, et al. Structure and transcription of human papillomavirus sequences in cervical carcinoma cells. *Nature* 1985; 314(6006): 111–114.
5. Human papillomaviruses. WHO/IARC, Lyon, France, 1995. Volume 64, 1–6.
6. Kreider JW, Howett MK, Wolfe SA, et al. Morphological transformation in vivo of human uterine cervix with papillomavirus from condylomata acuminata. *Nature* 1985; 317(6038): 639–641.
7. Durst M, Dzarlieva-Petrusevska RT, Boukamp P, Fusenig NE, Gissmann L. Molecular and cytogenetic analysis of immortalized human primary keratinocytes obtained after transfection with human papillomavirus type 16 DNA. *Oncogene* 1987; 1(3): 251–256.
8. Hawley-Nelson P, Vousden KH, Hubbert NL, Lowy DR, Schiller JT. HPV16 E6 and E7 proteins cooperate to immortalize human foreskin keratinocytes. *Embo J* 1989; 8(12): 3905–3910.
9. Strickler HD, Dillner J, Schiffman MH, et al. A seroepidemiologic study of HPV infection and incident cervical squamous intraepithelial lesions. *Viral Immunol* 1994; 7(4): 169–177.

10. Jha PK, Beral V, Peto J, et al. Antibodies to human papillomavirus and to other genital infectious agents and invasive cervical cancer risk. *Lancet* 1993; 341(8853): 1116–1118.
11. Koutsky LA, Ault KA, Wheeler CM, et al. A controlled trial of a human papillomavirus type 16 vaccine. *N Engl J Med* 2002; 347(21): 1645–1651.
12. de Villiers EM. Human pathogenic papillomavirus types: an update. *Curr Top Microbiol Immunol* 1994; 186: 1–12.
13. Centers for Disease Control and Prevention (CDC). MMWR Morb. Mortal. Wkly. Rep. 2006; 55(41): 1118–20.
14. Koutsky LA, Galloway DA, Holmes KK. Epidemiology of genital human papillomavirus infection. *Epidemiol Rev* 1988; 10: 122–163.
15. Munoz N, Bosch FX, de Sanjose S, et al. Epidemiologic classification of human papillomavirus types associated with cervical cancer. *N Engl J Med* 2003; 348(6): 518–527.
16. Parkin DM, Bray F, Ferlay J, Pisani P. Global cancer statistics 2002. *CA Cancer J Clin* 2005; 55(2): 74–108.
17. Clifford GM, Gallus S, Herrero R, et al. Worldwide distribution of human papillomavirus types in cytologically normal women in the International Agency for Research on Cancer HPV prevalence surveys: a pooled analysis. *Lancet* 2005; 366(9490): 991–998.
18. Baker C, Calef C. Maps of Papillomavirus mRNA Transcripts. *HPV Compendium* 1997.III–3.
19. Baker TS, Newcomb WW, Olson NH, Cowsert LM, Olson C, Brown JC. Structures of bovine and human papillomaviruses. Analysis by cryoelectron microscopy and three-dimensional image reconstruction. *Biophys J* 1991; 60(6): 1445–1456.
20. Modis Y, Trus BL, Harrison SC. Atomic model of the papillomavirus capsid. *Embo J* 2002; 21(18): 4754–4762.
21. Finnen RL, Erickson KD, Chen XS, Garcea RL. Interactions between papillomavirus L1 and L2 capsid proteins. *J Virol* 2003; 77(8): 4818–4826.
22. You J, Croyle JL, Nishimura A, Ozato K, Howley PM. Interaction of the bovine papillomavirus E2 protein with Brd4 tethers the viral DNA to host mitotic chromosomes. *Cell* 2004; 117(3): 349–360.
23. Doorbar J, Campbell D, Grand RJ, Gallimore PH. Identification of the human papilloma virus-1a E4 gene products. *Embo J* 1986; 5(2): 355–362.
24. Kawana Y, Kawana K, Yoshikawa H, Taketani Y, Yoshiike K, Kanda T. Human papillomavirus type 16 minor capsid protein L2 N-terminal region containing a common neutralization epitope binds to the cell surface and enters the cytoplasm. *J Virol* 2001; 75(5): 2331–2336.
25. Patterson NA, Smith JL, Ozburn MA. Human papillomavirus type 31b infection of human keratinocytes does not require heparan sulfate. *J Virol* 2005; 79(11): 6838–6847.
26. Yang R, Day PM, Yutzy WHT, Lin KY, Hung CF, Roden RB. Cell surface-binding motifs of L2 that facilitate papillomavirus infection. *J Virol* 2003; 77(6): 3531–3541.
27. Richards RM, Lowy DR, Schiller JT, Day PM. Cleavage of the papillomavirus minor capsid protein, L2, at a furin consensus site is necessary for infection. *Proc Natl Acad Sci USA* 2006; 103(5): 1522–1527.
28. Bossis I, Roden RB, Gambhira R, et al. Interaction of tSNARE syntaxin 18 with the papillomavirus minor capsid protein mediates infection. *J Virol* 2005; 79(11): 6723–6731.
29. Yang R, Yutzy WH, Viscidi RP, Roden RB. Interaction of L2 with beta-actin directs intracellular transport of papillomavirus and infection. *J Biol Chem* 2003; 278(14): 12,546–12,553.
30. Day PM, Roden RB, Lowy DR, Schiller JT. The papillomavirus minor capsid protein, L2, induces localization of the major capsid protein, L1, and the viral transcription/replication protein, E2, to PML oncogenic domains. *J Virol* 1998; 72(1): 142–150.
31. Day PM, Baker CC, Lowy DR, Schiller JT. Establishment of papillomavirus infection is enhanced by promyelocytic leukemia protein (PML) expression. *Proc Natl Acad Sci USA* 2004; 101(39): 14,252–14,257.
32. Hildesheim A, Schiffman MH, Gravitt PE, et al. Persistence of type-specific human papillomavirus infection among cytologically normal women. *J Infect Dis* 1994; 169(2): 235–240.
33. Ho GY, Studentsov YY, Bierman R, Burk RD. Natural history of human papillomavirus type 16 virus-like particle antibodies in young women. *Cancer Epidemiol Biomarkers Prev* 2004; 13(1): 110–116.
34. Ferenczy A, Franco E. Persistent human papillomavirus infection and cervical neoplasia. *Lancet Oncol* 2002; 3(1): 11–16.
35. Ali SZ, Steinberg DM, Rosenthal DL, Chan TY, Burroughs F. Cytopathology Tutorial: The Johns Hopkins University School of Medicine Department of Pathology Division of Cytopathology, 2002. [http://pathology2.jhu.edu/cyto\\_tutorial/Atlas/Index.cfm](http://pathology2.jhu.edu/cyto_tutorial/Atlas/Index.cfm)

36. Holowaty P, Miller AB, Rohan T, To T. Natural history of dysplasia of the uterine cervix. *J Natl Cancer Inst* 1999; 91(3): 252–258.
37. Marchetti B, Ashrafi GH, Dornan ES, Araibi EH, Ellis SA, Campo MS. The E5 protein of BPV-4 interacts with the heavy chain of MHC class I and irreversibly retains the MHC complex in the Golgi apparatus. *Oncogene* 2006; 25(15): 2254–2263.
38. Barnard P, McMillan NA. The human papillomavirus E7 oncoprotein abrogates signaling mediated by interferon-alpha. *Virology* 1999; 259(2): 305–313.
39. Park JS, Kim EJ, Kwon HJ, Hwang ES, Namkoong SE, Um SJ. Inactivation of interferon regulatory factor-1 tumor suppressor protein by HPV E7 oncoprotein. Implication for the E7-mediated immune evasion mechanism in cervical carcinogenesis. *J Biol Chem* 2000; 275(10): 6764–6769.
40. Trimble CL, Piantadosi S, Gravitt P, et al. Spontaneous regression of high-grade cervical dysplasia: effects of human papillomavirus type and HLA phenotype. *Clin Cancer Res* 2005; 11(13): 4717–4723.
41. Ross GL. Oral contraceptives and cervical cancer. *Lancet* 2002; 360(9330): 409; author reply 409.
42. Brinton LA. Oral contraceptives and cervical neoplasia. *Contraception* 1991; 43(6): 581–595.
43. Hormonal contraception and post-menopausal hormonal therapy. International Agency for Research on Cancer, Lyon, France, 1999. IARC Monograph vol 721–660
44. Brinton LA, Reeves WC, Brenes MM, et al. Parity as a risk factor for cervical cancer. *Am J Epidemiol* 1989; 130(3): 486–496.
45. Parazzini F, Chatenoud L, La Vecchia C, Negri E, Franceschi S, Bolis G. Determinants of risk of invasive cervical cancer in young women. *Br J Cancer* 1998; 77(5): 838–841.
46. Moreno V, Bosch FX, Munoz N, et al. Effect of oral contraceptives on risk of cervical cancer in women with human papillomavirus infection: the IARC multicentric case-control study. *Lancet* 2002; 359(9312): 1085–1092.
47. Berrington A, Jha P, Peto J, Green J, Hermon C. Oral contraceptives and cervical cancer. *Lancet* 2002; 360(9330): 410.
48. Deacon JM, Evans CD, Yule R, et al. Sexual behaviour and smoking as determinants of cervical HPV infection and of CIN3 among those infected: a case-control study nested within the Manchester cohort. *Br J Cancer* 2000; 83(11): 1565–1572.
49. Munoz N, Franceschi S, Bosetti C, et al. Role of parity and human papillomavirus in cervical cancer: the IARC multicentric case-control study. *Lancet* 2002; 359(9312): 1093–1101.
50. Brabin L, Barr F. Oral contraceptives and cervical cancer. *Lancet* 2002; 360(9330): 409–410.
51. Skegg DC. Oral contraceptives, parity, and cervical cancer. *Lancet* 2002; 359(9312): 1080–1081.
52. Dong G, Broker TR, Chow LT. Human papillomavirus type 11 E2 proteins repress the homologous E6 promoter by interfering with the binding of host transcription factors to adjacent elements. *J Virol* 1994; 68(2): 1115–1127.
53. Dostatni N, Lambert PF, Sousa R, Ham J, Howley PM, Yaniv M. The functional BPV-1 E2 transactivating protein can act as a repressor by preventing formation of the initiation complex. *Genes Dev* 1991; 5(9): 1657–1671.
54. Dowhanick JJ, McBride AA, Howley PM. Suppression of cellular proliferation by the papillomavirus E2 protein. *J Virol* 1995; 69(12): 7791–7799.
55. Scheffner M, Werness BA, Huibregtse JM, Levine AJ, Howley PM. The E6 oncoprotein encoded by human papillomavirus types 16 and 18 promotes the degradation of p53. *Cell* 1990; 63(6): 1129–1136.
56. Dyson N, Howley PM, Munger K, Harlow E. The human papilloma virus-16 E7 oncoprotein is able to bind to the retinoblastoma gene product. *Science* 1989; 243(4893): 934–937.
57. Zerfass K, Levy LM, Cremonesi C, et al. Cell cycle-dependent disruption of E2F-p107 complexes by human papillomavirus type 16 E7. *J Gen Virol* 1995; 76(Pt 7): 1815–1820.
58. Cellular proteins. *HPV Compendium* 1997. IV-1–IV-4
59. Hebner CM, Laimins LA. Human papillomaviruses: basic mechanisms of pathogenesis and oncogenicity. *Rev Med Virol* 2006; 87(11): 3183–3193.
60. Moodley M. Update on pathophysiologic mechanisms of human papillomavirus. *Curr Opin Obstet Gynecol* 2005; 17(1): 61–64.
61. Motoyama S, Ladines-Llave CA, Luis Villanueva S, Maruo T. The role of human papilloma virus in the molecular biology of cervical carcinogenesis. *Kobe J Med Sci* 2004; 50(1–2): 9–19.
62. Hagensee ME, Yaegashi N, Galloway DA. Self-assembly of human papillomavirus type 1 capsids by expression of the L1 protein alone or by coexpression of the L1 and L2 capsid proteins. *J Virol* 1993; 67(1): 315–322.

63. Kirnbauer R, Booy F, Cheng N, Lowy DR, Schiller JT. Papillomavirus L1 major capsid protein self-assembles into virus-like particles that are highly immunogenic. *Proc Natl Acad Sci USA* 1992; 89(24): 12,180–12,184.
64. Kirnbauer R, Taub J, Greenstone H, et al. Efficient self-assembly of human papillomavirus type 16 L1 and L1-L2 into virus-like particles. *J Virol* 1993; 67(12): 6929–6936.
65. Schiller JT and Nardelli-Haeffliger. chapter 17: second generation HPV vaccines to prevent cervical cancer (2006) vaccine vol 24, supplement 3 pages, S147–S153.
66. Nardelli-Haeffliger D, Lurati F, Wirthner D, et al. Immune responses induced by lower airway mucosal immunisation with a human papillomavirus type 16 virus-like particle vaccine. *Vaccine* 2005; 23(28): 3634–3641.
67. Mao C, Koutsky LA, Ault KA, et al. Efficacy of human papillomavirus-16 vaccine to prevent cervical intraepithelial neoplasia: a randomized controlled trial. *Obstet Gynecol* 2006; 107(1): 18–27.
68. Herrero R, Hildesheim A, Bratti C, et al. Rationale and design of the NCI-Costa Rica HPV 16 vaccine trial. 19th International Papillomavirus Conference Florianopolis, Brazil, 2001, pp. 94.
69. Ruiz W, McClements WL, Jansen KU, Esser MT. Kinetics and isotype profile of antibody responses in rhesus macaques induced following vaccination with HPV 6, 11, 16 and 18 L1-virus-like particles formulated with or without Merck aluminum adjuvant. *J Immune Based Ther Vaccines* 2005; 3(1): 2.
70. GlaxoSmithKline. 22nd International Papillomavirus Conference 2005.
71. Roden RB, Greenstone HL, Kirnbauer R, et al. In vitro generation and type-specific neutralization of a human papillomavirus type 16 virion pseudotype. *J Virol* 1996; 70(9): 5875–5883.
72. Munoz N, Bosch FX, Castellsague X, et al. Against which human papillomavirus types shall we vaccinate and screen? The international perspective. *Int J Cancer* 2004; 111(2): 278–285.
73. Harper DM, Franco EL, Wheeler C, et al. Efficacy of a bivalent L1 virus-like particle vaccine in prevention of infection with human papillomavirus types 16 and 18 in young women: a randomised controlled trial. *Lancet* 2004; 364(9447): 1757–1765.
74. Villa LL, Costa RL, Petta CA, et al. Prophylactic quadrivalent human papillomavirus (types 6, 11, 16, and 18) L1 virus-like particle vaccine in young women: a randomised double-blind placebo-controlled multicentre phase II efficacy trial. *Lancet Oncol* 2005; 6(5): 271–278.
75. Roden RB, Yutzy WH, Fallon R, Inglis S, Lowy DR, Schiller JT. Minor capsid protein of human genital papillomaviruses contains subdominant, cross-neutralizing epitopes. *Virology* 2000; 270(2): 254–257.
76. Embers ME, Budgeon LR, Culp TD, Reed CA, Pickel MD, Christensen ND. Differential antibody responses to a distinct region of human papillomavirus minor capsid proteins. *Vaccine* 2004; 22(5–6): 670–680.
77. HPV and animal PV nucleic acid sequences. *HPV Compendium* 1997. <http://npv-web.lanl.gov/std-gen/virus/hpv/compendium/htdocs/>.
78. Chen XS, Casini G, Harrison SC, Garcea RL. Papillomavirus capsid protein expression in *Escherichia coli*: purification and assembly of HPV11 and HPV16 L1. *J Mol Biol* 2001; 307(1): 173–182.
79. Yuan H, Estes PA, Chen Y, et al. Immunization with a pentameric L1 fusion protein protects against papillomavirus infection. *J Virol* 2001; 75(17): 7848–7853.
80. Giles M, Garland S. Chapter 21: HPV Vaccines. In: *Papillomavirus Research* (Campo MS, ed.), Norfolk, England: Caister Academic Press, 2006: 341–356.
81. Kawana K, Yasugi T, Kanda T, et al. Neutralizing antibodies against oncogenic human papillomavirus as a possible determinant of the fate of low-grade cervical intraepithelial neoplasia. *Biochem Biophys Res Commun* 2002; 296(1): 102–105.
82. Halpert R, Fruchter RG, Sedlis A, Butt K, Boyce JG, Sillman FH. Human papillomavirus and lower genital neoplasia in renal transplant patients. *Obstet Gynecol* 1986; 68(2): 251–258.
83. Laga M, Icenogle JP, Marsella R, et al. Genital papillomavirus infection and cervical dysplasia—opportunistic complications of HIV infection. *Int J Cancer* 1992; 50(1): 45–48.
84. Schafer A, Friedmann W, Mielke M, Schwartlander B, Koch MA. The increased frequency of cervical dysplasia-neoplasia in women infected with the human immunodeficiency virus is related to the degree of immunosuppression. *Am J Obstet Gynecol* 1991; 164(2): 593–599.
85. Sun XW, Kuhn L, Ellerbrock TV, Chiasson MA, Bush TJ, Wright TC Jr. Human papillomavirus infection in women infected with the human immunodeficiency virus. *N Engl J Med* 1997; 337(19): 1343–1349.
86. Coleman N, Birley HD, Renton AM, et al. Immunological events in regressing genital warts. *Am J Clin Pathol* 1994; 102(6): 768–774.

87. Rensing ME, van Driel WJ, Brandt RM, et al. Detection of T helper responses, but not of human papillomavirus-specific cytotoxic T lymphocyte responses, after peptide vaccination of patients with cervical carcinoma. *J Immunother* 2000; 23(2): 255–266.
88. van Driel WJ, Rensing ME, Kenter GG, et al. Vaccination with HPV16 peptides of patients with advanced cervical carcinoma: clinical evaluation of a phase I-II trial. *Eur J Cancer* 1999; 35(6): 946–952.
89. Steller MA, Gurski KJ, Murakami M, et al. Cell-mediated immunological responses in cervical and vaginal cancer patients immunized with a lipidated epitope of human papillomavirus type 16 E7. *Clin Cancer Res* 1998; 4(9): 2103–2109.
90. Muderspach L, Wilczynski S, Roman L, et al. A phase I trial of a human papillomavirus (HPV) peptide vaccine for women with high-grade cervical and vulvar intraepithelial neoplasia who are HPV 16 positive. *Clin Cancer Res* 2000; 6(9): 3406–3416.
91. Adams M, Borysiewicz L, Fiander A, et al. Clinical studies of human papilloma vaccines in pre-invasive and invasive cancer. *Vaccine* 2001; 19(17–19): 2549–2556.
92. Borysiewicz LK, Fiander A, Nimako M, et al. A recombinant vaccinia virus encoding human papillomavirus types 16 and 18, E6 and E7 proteins as immunotherapy for cervical cancer. *Lancet* 1996; 347(9014): 1523–1527.
93. Kaufmann AM, Stern PL, Rankin EM, et al. Safety and immunogenicity of TA-HPV, a recombinant vaccinia virus expressing modified human papillomavirus (HPV)-16 and HPV-18 E6 and E7 genes, in women with progressive cervical cancer. *Clin Cancer Res* 2002; 8(12): 3676–3685.
94. Baldwin PJ, van der Burg SH, Boswell CM, et al. Vaccinia-expressed human papillomavirus 16 and 18 e6 and e7 as a therapeutic vaccination for vulval and vaginal intraepithelial neoplasia. *Clin Cancer Res* 2003; 9(14): 5205–5213.
95. Davidson EJ, Boswell CM, Sehr P, et al. Immunological and clinical responses in women with vulval intraepithelial neoplasia vaccinated with a vaccinia virus encoding human papillomavirus 16/18 oncoproteins. *Cancer Res* 2003; 63(18): 6032–6041.
96. Corona Gutierrez CM, Tinoco A, Navarro T, et al. Therapeutic vaccination with MVA E2 can eliminate precancerous lesions (CIN 1, CIN 2, and CIN 3) associated with infection by oncogenic human papillomavirus. *Hum Gene Ther* 2004; 15(5): 421–431.
97. Klencke B, Matijevic M, Urban RG, et al. Encapsulated plasmid DNA treatment for human papillomavirus 16-associated anal dysplasia: a Phase I study of ZYC101. *Clin Cancer Res* 2002; 8(5): 1028–1037.
98. Sheets EE, Urban RG, Crum CP, et al. Immunotherapy of human cervical high-grade cervical intraepithelial neoplasia with microparticle-delivered human papillomavirus 16 E7 plasmid DNA. *Am J Obstet Gynecol* 2003; 188(4): 916–926.
99. Garcia F, Petry KU, Muderspach L, et al. ZYC101a for treatment of high-grade cervical intraepithelial neoplasia: a randomized controlled trial. *Obstet Gynecol* 2004; 103(2): 317–326.
100. de Jong A, O'Neill T, Khan AY, et al. Enhancement of human papillomavirus (HPV) type 16 E6 and E7-specific T-cell immunity in healthy volunteers through vaccination with TA-CIN, an HPV16 L2E7E6 fusion protein vaccine. *Vaccine* 2002; 20(29–30): 3456–3464.
101. Meyers C, Frattini MG, Hudson JB, Laimins LA. Biosynthesis of human papillomavirus from a continuous cell line upon epithelial differentiation. *Science* 1992; 257(5072): 971–973.
102. Stoler MH, Rhodes CR, Whitbeck A, Wolinsky SM, Chow LT, Broker TR. Human papillomavirus type 16 and 18 gene expression in cervical neoplasias. *Hum Pathol* 1992; 23(2): 117–128.
103. Hu G, Liu W, Hanania EG, Fu S, Wang T, Deisseroth AB. Suppression of tumorigenesis by transcription units expressing the antisense E6 and E7 messenger RNA (mRNA) for the transforming proteins of the human papilloma virus and the sense mRNA for the retinoblastoma gene in cervical carcinoma cells. *Cancer Gene Ther* 1995; 2(1): 19–32.
104. Chen G, Stenlund A. The E1 initiator recognizes multiple overlapping sites in the papillomavirus origin of DNA replication. *J Virol* 2001; 75(1): 292–302.
105. Hughes FJ, Romanos MA. E1 protein of human papillomavirus is a DNA helicase/ATPase. *Nucleic Acids Res* 1993; 21(25): 5817–5823.
106. Conger KL, Liu JS, Kuo SR, Chow LT, Wang TS. Human papillomavirus DNA replication. Interactions between the viral E1 protein and two subunits of human dna polymerase alpha/primase. *J Biol Chem* 1999; 274(5): 2696–2705.

107. Frattini MG, Laimins LA. Binding of the human papillomavirus E1 origin-recognition protein is regulated through complex formation with the E2 enhancer-binding protein. *Proc Natl Acad Sci USA* 1994; 91(26): 12,398–12,402.
108. Frattini MG, Hurst SD, Lim HB, Swaminathan S, Laimins LA. Abrogation of a mitotic checkpoint by E2 proteins from oncogenic human papillomaviruses correlates with increased turnover of the p53 tumor suppressor protein. *Embo J* 1997; 16(2): 318–331.
109. Doorbar J, Ely S, Sterling J, McLean C, Crawford L. Specific interaction between HPV-16 E1-E4 and cytokeratins results in collapse of the epithelial cell intermediate filament network. *Nature* 1991; 352(6338): 824–827.
110. Raj K, Berguerand S, Southern S, Doorbar J, Beard P. E1 empty set E4 protein of human papillomavirus type 16 associates with mitochondria. *J Virol* 2004; 78(13): 7199–7207.
111. Crusius K, Auvinen E, Steuer B, Gaissert H, Alonso A. The human papillomavirus type 16 E5-protein modulates ligand-dependent activation of the EGF receptor family in the human epithelial cell line HaCaT. *Exp Cell Res* 1998; 241(1): 76–83.
112. Straight SW, Hinkle PM, Jewers RJ, McCance DJ. The E5 oncoprotein of human papillomavirus type 16 transforms fibroblasts and effects the downregulation of the epidermal growth factor receptor in keratinocytes. *J Virol* 1993; 67(8): 4521–4532.
113. Genter Williams SM, Disbrow GL, Schlegel R, Lee D, Threadgill DW, Lambert PF. Requirement of epidermal growth factor receptor for hyperplasia induced by E5, a high-risk human papillomavirus oncogene. *Cancer Res* 2005; 65(15): 6534–6542.
114. Cohen BD, Goldstein DJ, Rutledge L, et al. Transformation-specific interaction of the bovine papillomavirus E5 oncoprotein with the platelet-derived growth factor receptor transmembrane domain and the epidermal growth factor receptor cytoplasmic domain. *J Virol* 1993; 67(9): 5303–5311.
115. Gardiol D, Kuhne C, Glaunsinger B, Lee SS, Javier R, Banks L. Oncogenic human papillomavirus E6 proteins target the discs large tumour suppressor for proteasome-mediated degradation. *Oncogene* 1999; 18(40): 5487–5496.
116. Tong X, Howley PM. The bovine papillomavirus E6 oncoprotein interacts with paxillin and disrupts the actin cytoskeleton. *Proc Natl Acad Sci USA* 1997; 94(9): 4412–4417.
117. Tong X, Boll W, Kirchhausen T, Howley PM. Interaction of the bovine papillomavirus E6 protein with the clathrin adaptor complex AP-1. *J Virol* 1998; 72(1): 476–482.
118. Klingelhutz AJ, Foster SA, McDougall JK. Telomerase activation by the E6 gene product of human papillomavirus type 16. *Nature* 1996; 380(6569): 79–82.
119. Matthews K, Leong CM, Baxter L, et al. Depletion of Langerhans cells in human papillomavirus type 16-infected skin is associated with E6-mediated down regulation of E-cadherin. *J Virol* 2003; 77(15): 8378–8385.
120. Ronco LV, Karpova AY, Vidal M, Howley PM. Human papillomavirus 16 E6 oncoprotein binds to interferon regulatory factor-3 and inhibits its transcriptional activity. *Genes Dev* 1998; 12(13): 2061–2072.
121. Joyce JG, Tung JS, Przysiecki CT, et al. The L1 major capsid protein of human papillomavirus type 11 recombinant virus-like particles interacts with heparin and cell-surface glycosaminoglycans on human keratinocytes. *J Biol Chem* 1999; 274(9): 5810–5822.
122. Roden RB, Kirnbauer R, Jenson AB, Lowy DR, Schiller JT. Interaction of papillomaviruses with the cell surface. *J Virol* 1994; 68(11): 7260–7266.
123. Harro CD, Pang YY, Roden RB, et al. Safety and immunogenicity trial in adult volunteers of a human papillomavirus 16 L1 virus-like particle vaccine. *J Natl Cancer Inst* 2001; 93(4): 284–292.
124. Pinto LA, Castle PE, Roden RB, et al. HPV-16 L1 VLP vaccine elicits a broad-spectrum of cytokine responses in whole blood. *Vaccine* 2005; 23(27): 3555–3564.
125. Pinto LA, Edwards J, Castle PE, et al. Cellular immune responses to human papillomavirus (HPV)-16 L1 in healthy volunteers immunized with recombinant HPV-16 L1 virus-like particles. *J Infect Dis* 2003; 188(2): 327–338.
126. Ault KA, Giuliano AR, Edwards RP, et al. A phase I study to evaluate a human papillomavirus (HPV) type 18 L1 VLP vaccine. *Vaccine* 2004; 22(23–24): 3004–3007.
127. Kawana K, Yasugi T, Kanda T, et al. Safety and immunogenicity of a peptide containing the cross-neutralization epitope of HPV16 L2 administered nasally in healthy volunteers. *Vaccine* 2003; 21(27–30): 4256–4260.

128. Hallez S, Simon P, Maudoux F, et al. Phase I/II trial of immunogenicity of a human papillomavirus (HPV) type 16 E7 protein-based vaccine in women with oncogenic HPV-positive cervical intraepithelial neoplasia. *Cancer Immunol Immunother* 2004; 53(7): 642–650.
129. Santin AD, Bellone S, Gokden M, Cannon MJ, Parham GP. Vaccination with HPV-18 E7-pulsed dendritic cells in a patient with metastatic cervical cancer. *N Engl J Med* 2002; 346(22): 1752–1753.
130. Santin AD, Bellone S, Palmieri M, et al. HPV16/18 E7-pulsed dendritic cell vaccination in cervical cancer patients with recurrent disease refractory to standard treatment modalities. *Gynecol Oncol* 2006; 100(3): 469–478.
131. Bosch FX, Lorincz A, Muñoz N, Meijer CJ, Shah KV. The causal relation between human papillomavirus and cervical cancer, *J Clin Pathol* 2002; 55: 244–265.

# V

---

## GESTATIONAL TROPHOBLASTIC DISEASE

---



# 10

---

## Pathogenesis of Gestational Trophoblastic Lesions

---

*Ie-Ming Shih, MD, PhD*  
*and Robert J. Kurman, MD, PhD*

### CONTENTS

INTRODUCTION
OVERVIEW OF TROPHOBLASTIC SUBPOPULATIONS IN NORMAL PLACENTA
CLASSIFICATION OF GTD
PATHOGENESIS OF INTERMEDIATE TROPHOBLASTIC LESIONS
CONCLUSION
REFERENCES

---

### 1. INTRODUCTION

Gestational trophoblastic disease (GTD) can be broadly divided into two groups, hydatidiform moles, which represent abnormally formed placentas, and trophoblastic tumors, and tumor-like lesions. In contrast to hydatidiform moles, the pathogenesis of trophoblastic tumors and tumor-like lesions is largely unknown. In recent years, progress has been made in elucidating the biology of human trophoblast. The identification and characterization of the genes expressed in human trophoblast has led to a further understanding of the lineage and differentiation program of trophoblast and related this to trophoblastic lesions. It is now clear that trophoblastic lesions recapitulate the trophoblast present in the early developing placenta and implantation site. In this chapter, some of these recent observations will be summarized and correlated with the morphology and biology of human trophoblast in normal placentation and in trophoblastic disease.

### 2. OVERVIEW OF TROPHOBLASTIC SUBPOPULATIONS IN NORMAL PLACENTA

Based on morphological, immunophenotypical, and functional studies, the trophoblast in villous and extravillous locations can be divided into three distinct populations: cytotrophoblast (CT), syncytiotrophoblast (ST), and intermediate trophoblast (IT) (1,2). The anatomical locations and functional aspects of each trophoblastic subpopulation are briefly summarized next.

From: *Current Clinical Oncology: Molecular Pathology of Gynecologic Cancer*  
Edited by: A. Giordano, A. Bovicelli, and R. Kurman © Humana Press Inc., Totowa, NJ

### **2.1. Cytotrophoblast**

CT functions as a stem cell and is located on the villous surface. CT expresses epidermal growth factor receptor (EGF-R), which binds with EGF secreted by the decidua (3). It has been postulated that through a paracrine-like mechanism, EGF-R and its ligand may provide growth stimulation for CT (4). CT differentiates along two main pathways. On the villous surface, CT fuses to form the overlying ST. This process results in expansion of the surface area of chorionic villi in the developing placenta. In the second pathway, CT in the trophoblastic column differentiates into villous IT and then into implantation site IT in the placental site or chorionic-type IT in the chorion laeve (5). The mechanisms underlying the differentiation of CT are unclear. Recently, however, expression of syncytin has been shown to be involved in the fusion of CT into ST (6) and downregulation of Id-2 is associated with differentiation into implantation site IT (7). In addition, it has been shown that CT expresses the  $\Delta N$  isoforms of p63, whereas chorionic-type IT in the fetal membranes expresses the TA isoforms (8). Implantation site IT and ST do not express either of the p63 isoforms. As p63 isoforms have specific functions including those that relate to regulation of apoptosis and proliferation, these findings suggest that p63 may act as a molecular switch. Thus, turning off or turning on specific p63 isoforms may in turn control trophoblastic differentiation and placental development. The expression of the  $\Delta N$  isoform in CT is consistent with its proposed function of maintaining basal or stem cells in a state where they are capable of proliferation and differentiation, perhaps by preventing cell-cycle arrest and inhibiting apoptosis (9). Thus, as CT differentiates into either ST or implantation site IT in the trophoblastic columns, there is a dramatic decrease in  $\Delta N$ p63 expression, which may contribute to cell-cycle arrest (10) as evidenced by the virtual absence of Ki-67 labeling in ST and implantation site IT (5,11).

### **2.2. Syncytiotrophoblast**

ST is made up of terminally differentiated cells that cover the chorionic villi and synthesizes and secretes a number of pregnancy-associated hormones including human placental lactogen (hPL), SP-1, and  $\beta$ -hCG (human chorionic gonadotropin). Some of these secretory proteins may also have a paracrine function by regulating the local microenvironment of decidual cells, inflammatory cells, and smooth muscle cells at the placental site. In addition to its role as an endocrine organ, the ST is bathed in maternal blood and is responsible for the exchange of oxygen, nutrients, and a variety of metabolic products between the mother and the fetus.

### **2.3. Villous IT**

Villous intermediate trophoblastic cells consist of the trophoblastic columns that anchor the chorionic villi to the basal plate of the implantation site. They proliferate in the proximal portion of the trophoblastic columns and are the source of implantation site and chorionic-type intermediate trophoblastic cells. In addition, they maintain the structural integrity of the trophoblastic columns. The distinctive molecular feature that characterizes the villous intermediate trophoblastic cells is the expression of HNK-1 carbohydrate, which is not present in any of the other trophoblastic subpopulations (12). The HNK-1 moiety is present on the cell surface and might contribute to intercellular cohesion in the trophoblastic columns, which counteracts the mechanical sheering forces resulting from fetal movement and the turbulence created by the

pulsatile blood flow in the placental bed (12). Moreover, several genes including CD146 (Mel-CAM), hPL, human leukocyte antigen (HLA-G), and cyclin E are expressed in villous intermediate trophoblastic cells. Further increasing from the proximal to the distal end of the trophoblastic column, and reflecting the differentiation of implantation site IT (Table 1).

#### 2.4. Implantation Site IT

The major function of implantation site IT is to establish the maternal–fetal circulation by invading the spiral arteries in the basal plate during early pregnancy (13). It has been suggested that the mechanisms underlying trophoblastic invasion are similar to those involved in tumor cell invasion (14,15). Because in both processes a variety of proteases, cell-adhesion molecules, growth factors and their receptors, and tumor-associated antigens including HLA-G and CD146 are expressed in both and there is also loss of E-cadherin expression (16). However, unlike malignant tumors, the invasion of implantation site IT is tightly regulated, confined spatially to the implantation site, and limited temporally to early pregnancy (4,13,17,18). Whereas, extensively infiltrating the endometrium of the basal plate, the implantation site IT invades only the inner third of the myometrium in the first trimester, decreasing to less than 10% of the myometrium by term. Although, the molecular mechanisms underlying the control of trophoblastic invasion are unclear, the invasive process can be modulated by both the trophoblast and the local microenvironment (4,17–19). Fusion of mononucleate implantation site intermediate trophoblastic cells with multinucleated cells leads to the loss of their invasive and migratory phenotype. Implantation site intermediate trophoblastic cells are not proliferative as they are negative for Ki-67, a proliferation marker, and are positive for several proteins, which are involved in the arrest of cell-cycle progression including p21<sup>WAF1/CIP1</sup> (20) and p57<sup>kip-2</sup> (21). It is of interest that implantation site intermediate trophoblastic cells express cyclin E, but its biological significance is unknown at present (22).

#### 2.5. Chorionic-Type IT

This type of IT is located in the chorion laeve (fetal membrane). Unlike implantation site intermediate trophoblastic cells, the functional role of chorionic-type intermediate trophoblastic cells remains speculative. Chorionic-type IT may contribute to the synthesis of extracellular matrix, which is required to maintain the tensile strength of the fetal membrane (23). It is also possible that chorionic-type IT acts as a biological and mechanical barrier to the maternal immune system and is important for fetal allograft survival. Chorionic-type intermediate trophoblastic cells express HLA-G and p63, but hPL and CD146 are expressed only focally (Table 1) (5,24). Chorionic-type intermediate trophoblastic cells are believed to differentiate from CT, but the molecular mechanisms that underlie this process are unknown.  $\Delta$ Np63 is expressed by CT and TAp63 is expressed by chorionic-type intermediate trophoblastic cells. It is conceivable that an isoform switch from  $\Delta$ Np63 to TAp63 may be important for the transformation of CT into chorionic-type IT in the fetal membranes (8). Further, in vitro studies are required to determine whether this interpretation is correct.

### 3. CLASSIFICATION OF GTD

The third World Health Organization classification of GTD has been modified to include recently described entities (Table 2). In the past, the exaggerated placental site

Table 1  
Gene-Expression Profiling in Trophoblastic Subpopulations and Lesions

<i>Trophoblastic types</i>	<i>Lesions</i>	<i>HLA-G</i>	<i>hPL</i>	<i>hCG</i>	<i>Cyclin E</i>	<i>p63</i>	<i>CD146</i>	<i>HNK1</i>	<i>E-cad</i>
CT	Choriocarcinoma	-	-	-	+	++	-	-	++
ST		-	++	++	-	-	-	-	-
Villous IT <sup>a</sup>		++	-/+	-	-/+	-	-/+	++	+/+
Implantation site IT	EPS, PSTT	++	++	- <sup>b</sup>	++	-	++	-	+
Chorionic type IT	PSN, ETT	++	+	-	+ <sup>c</sup>	++	+	-	++

<sup>a</sup>IT, intermediate trophoblast; EPS, exaggerated placental site; PSTT, placental site trophoblastic tumor; PSN, placental site nodule; ETT, epithelioid trophoblastic tumor.

<sup>b</sup>Except in multinucleated IT cells.

<sup>c</sup>Cyclin E staining is diffuse in ETT but only very focal in PSN and chorionic-type IT.

**Table 2**  
**Classification of GTD**

---

Molar lesions
Complete hydatidiform mole
Partial hydatidiform mole
Invasive mole
Nonmolar lesions
Choriocarcinoma
PSTT
ETT
Nonneoplastic benign lesions
Exaggerated placental site
Placental site nodule

---

(EPS) and placental site nodule were classified as “unclassified GTD.” Both lesions are benign and have a distinct histogenesis and morphological features that justify their separate designation. The third World Health Organization classification also includes epithelioid trophoblastic tumor (ETT), a recently described trophoblastic neoplasm distinct from choriocarcinoma and placental site trophoblastic tumor (PSTT). Based on morphological and immunophenotypic features (Table 1), nonmolar GTD can be related to the different subpopulations of trophoblast. Although, each lesion is a distinct entity, it is not unusual for a nonmolar trophoblastic lesion to display mixed histological features of choriocarcinoma, PSTT, and ETT, underscoring the plasticity of trophoblastic differentiation within these tumors (5,24).

## 4. PATHOGENESIS OF INTERMEDIATE TROPHOBLASTIC LESIONS

### 4.1. Choriocarcinoma

Gestational choriocarcinoma is a highly malignant epithelial tumor that can be associated with any type of gestational event, most often a complete hydatidiform mole. Choriocarcinoma recapitulates the differentiation of cytotrophoblastic cells in early gestation. It may arise from neoplastic transformation of CT. Neoplastic CT, similar to its normal counterpart, retains its capacity to differentiate into ST and IT. As an intimate mixture of CT, IT, and ST is characteristic of choriocarcinoma. The CT and IT tend to grow in clusters and sheets, separated by ST, forming the characteristic dimorphic growth pattern of mononucleate trophoblast and ST. In choriocarcinoma, the percent of IT, as defined by CD146 (Mel-CAM) positive trophoblastic cells, is highly variable ranging from 1 to 90% of the mononucleate trophoblastic cellular population (25). The preliminary findings using immunohistochemical staining for  $\beta$ -catenin in choriocarcinoma demonstrate that  $\beta$ -catenin is localized in the nucleus in CT in contrast to its localization on the cell membrane in the adjacent IT. This pattern is similar to the distribution of  $\beta$ -catenin in the CT in the normal placenta. This finding suggests that  $\beta$ -catenin translocation to the nucleus may contribute to the cellular proliferation of trophoblastic cells in choriocarcinoma.

Choriocarcinoma has no intrinsic vascular stroma; the tumor receives its vascular supply by vascular invasion exclusively. However, infiltrative growth of normal tissues

and blood vessels can give the appearance of a vascular framework (26). The “pseudovasculogenesis” without neovasculogenesis permits an efficient blood supply to the tumor and contributes to the rapid growth of choriocarcinoma. This *in vivo* observation can be experimentally demonstrated in animals. The human choriocarcinoma cell line, JEG-3 when established in the subcutaneous tissue of mice, grows rapidly, forms intricate “vascular” channels lined by JEG-3 trophoblastic cells and not with host endothelial cells, and replaces the normal endothelium within the tumor xenograft (27). This animal model might be useful for experimental studies of the biology of choriocarcinoma, especially, the process of “pseudovasculogenesis.”

As in complete moles, synergistic upregulation of *c-myc*, *c-erb-2*, *c-fms*, and *bcl-2* oncoproteins appears to play an important role in the pathogenesis of choriocarcinoma (28). Mutational analysis of *K-ras* and *p53* has failed to show mutations of these genes in choriocarcinoma (28–30), although overexpression of *p53* has occasionally been found in choriocarcinoma (31). The other genes that are potentially involved in the development of choriocarcinoma include *DOC-2/hDab2*, a candidate tumor suppressor gene (32,33), and a putative tumor suppressor gene(s) located on chromosome 7p12-7q11.23 (34). Also, the ras GTPase activating protein (35) and HLA-G, which may participate in escape of immunosurveillance of tumor cells (36).

#### 4.2. Exaggerated Placental Site

The EPS is a benign nonneoplastic lesion characterized by an increased number of implantation site intermediate trophoblastic cells that extensively infiltrate the endometrium and underlying myometrium. The EPS can occur in a normal pregnancy, an abortion from the first trimester or a molar pregnancy, especially, a complete mole (24). The trophoblastic cells in an EPS display an identical morphological and immunophenotypical profile to the implantation site intermediate trophoblastic cells in the normal placental site. For example, they are strongly positive for CD146, HLA-G, and hPL, moderately positive for EGF-R and E-cadherin, and negative for p63, HNK-1, and  $\beta$ -hCG (except in the multinucleated intermediate trophoblastic cells). These findings indicate that the differentiation of IT is unaltered in an EPS, and support the view that an EPS is a normal variation of an implantation site (5,25). Despite the extensive infiltration of IT in an EPS, the Ki-67 indices of IT are near zero, suggesting that the increased number of IT in EPS is probably not the result of *de novo* proliferation of IT in the implantation site (24,25). The precise mechanism underlying the increased number of IT in EPS remains unclear, but may be because of rapid cell-cycle progression of IT in the trophoblastic columns or the suppression of apoptosis of IT in the implantation site.

#### 4.3. Placental Site Trophoblastic Tumor

The PSTT is a relatively uncommon form of trophoblastic tumors that is made up of neoplastic implantation site intermediate trophoblastic cells (8,24,37,38). In contrast to the normal implantation site in which invasion of IT is tightly regulated and is confined to the inner third of the myometrium, the tumor cells of PSTT are highly invasive and infiltrate deeply into the myometrium occasionally penetrating to the serosa.

Microscopically, PSTT resembles the trophoblastic infiltration of the endometrium and myometrium of the placental site during early pregnancy. The predominant cell

type in PSTT is implantation site IT (Table 1). PSTT is diffusely positive for HLA-G, hPL, and CD146 (Mel-CAM), but rarely positive for  $\beta$ -hCG, PIAP, p63, or HNK-1, an immunophenotype consistent with implantation site IT (Table 1) (5,24). PSTT is associated with abnormal expression of cell-cycle regulatory gene products including cyclins, cyclin-dependent kinases, and p53 (39). At the molecular genetic level, most PSTTs are diploid based on flow cytometric DNA analysis. The trophoblastic origin of PSTT has been confirmed by molecular genetic studies showing that they contain a Y chromosomal locus and/or new (paternal) alleles not present in adjacent normal uterine tissue in all informative cases (37,40,41). PSTTs express the activated (phosphorylated) form of mitogen activated protein kinase (MAPK) in 84% of cases; whereas normal intermediate trophoblastic cells do not (42). The RAS/RAF/MEK (MAPK/ERK Kinase)/MAPK signaling pathway is known to play a major role in various cellular activities including proliferation, differentiation, apoptosis, angiogenesis, and migration (43–49). In order to characterize the role of MAPK activation in PSTT, Kobel et al. (42) established the first PSTT cell culture, IST-2, from a surgically resected PSTT. IST-2 cells expressed HLA-G and Mel-CAM, but not E-cadherin, an immunophenotype characteristic of PSTT. IST-2 cells are highly motile and invasive in culture. Treatment with MEK inhibitors, CI-1040 and PD59089, which prevents activation of MAPK significantly, reduces the motility and invasion of IST-2 based on wound assay, cell tracking by time-lapse videomicroscopy, and invasion chamber assays. In contrast, neither of the compounds has an effect on normal intermediate trophoblastic cells in the implantation site. These findings demonstrate a functional role of MAPK activation in the motility and invasion of PSTT.

#### ***4.4. Placental Site Nodule***

Placental site nodules are small, well-circumscribed nodular aggregates of chorionic-type intermediate trophoblastic cells that are embedded in a hyalinized stroma. Placental site nodules have been believed to represent a portion of uninvolved placental site from a remote gestation. However, the constituent cells in placental site nodules are morphologically more closely related to the IT of the chorion laeve (chorionic-type intermediate trophoblast) than to the IT of the placental site (implantation site intermediate trophoblastic cells) (50). In addition, the trophoblastic cells in the placental site nodule exhibit an immunophenotype similar to that of trophoblastic cells in the chorion laeve, but distinct from implantation site IT (Table 1). The cells in a placental site nodule react with the antibody against p63, but only very focally with CD146 and hPL, an immunophenotype that characterizes the intermediate trophoblastic cells in chorionic laeve, but not the implantation site. These findings suggest that placental site nodules are derived from chorionic-type intermediate trophoblast. It remains a mystery, how these cells (from chorion laeve) are retained and survive in the uterus several years after delivery.

#### ***4.5. Epithelioid Trophoblastic Tumor***

ETT is an unusual type of trophoblastic tumor that is distinct from PSTT and choriocarcinoma with morphological features resembling a carcinoma (51). Microscopically, ETTs are nodular and generally well circumscribed although focal infiltrative features can be present at the periphery. The tumors are made up of chorionic-type intermediate trophoblastic cells. A characteristic type of geographic cell necrosis is frequently

observed. The trophoblastic origin of ETT has been confirmed by a molecular genetic analysis demonstrating that they contain a Y chromosomal locus and/or new (paternal) alleles not present in adjacent normal uterine tissue in all informative cases (37). The molecular features of ETTs are largely unknown, as this tumor has only been recently recognized. The tumors express cytokeratin, epithelial membrane antigen, E-cadherin, and EGF-R consistent with their epithelial origin. In addition, all the tumors are positive for p63, but only focally positive for hPL,  $\beta$ -hCG, and Mel-CAM, an immunophenotype identical to that observed in chorionic-type IT (8,24,50,52). Expression of the *p63* gene, a transcription factor belonging to the p53 family, characterizes ETT. As discussed previously, p63 has various isoforms that are classified into two groups designated TA and  $\Delta$ Np63 isoforms (8). The TA isoforms have a p53-like suppressor function, whereas the  $\Delta$ Np63 isoforms exert an oncogenic effect. Based on immunohistochemistry and reverse transcriptase polymerase chain reaction, it appears that CT expresses the  $\Delta$ Np63 isoform, whereas chorionic-type IT in the fetal membranes, placental site nodules, and ETT express the TAp63 isoform. The proliferative activity of ETT is relatively low as the mean Ki-67 labeling index in ETTs is  $17.7 \pm 4.5\%$  (mean  $\pm$  standard deviation) with a range from 10 to 25% (51). The expression of cyclin E in ETTs, but not in the majority of placental site nodules (22), suggests that cyclin E probably plays a role in neoplastic transformation of ETT as its oncogenic role had been demonstrated in other neoplastic diseases (53). Because placental site nodules are also made up of chorionic-type intermediate trophoblast, it has been hypothesized that some placental site nodules may represent a stage in tumor progression to ETTs. This view is supported by the observations that some proliferative placental site nodules with slightly higher cytological atypia tentatively classified as "atypical placental site nodules" have features intermediate between typical placental site nodules and ETTs. The percent of cyclin E-stained trophoblastic cells in an atypical placental site nodule is in between a conventional placental site nodule and an ETT, further supporting the aforementioned hypothesis (22). Moreover, in some cases, there is an intimate association of an ETT with a placental site nodule. Nevertheless, molecular genetic studies are necessary in order to confirm this hypothesis.

## 5. CONCLUSION

In conclusion, recent advances in molecular studies of trophoblastic cells in the normal placenta, implantation site, and in trophoblastic lesions have shown that the latter recapitulate the normal trophoblast in the early developing placenta and implantation site. This new knowledge, especially, the identification and characterization of the genes expressed in human trophoblast will help elucidate the pathogenesis of trophoblastic lesions, and will also provide a foundation to facilitate the pathological diagnosis of various types of trophoblastic tumors and tumor-like lesions.

## REFERENCES

1. Kurman RJ, Main CS, Chen HC. Intermediate trophoblast: a distinctive form of trophoblast with specific morphological, biochemical and functional features. *Placenta* 1984; 5: 349–370.
2. Kurman RJ. The morphology, biology, and pathology of intermediate trophoblast: a look back to the present. *Hum Pathol* 1991; 22: 847–855.
3. Haining RE, Cameron IT, van Papendorp C, et al. Epidermal growth factor in human endometrium: proliferative effects in culture and immunocytochemical localization in normal and endometriotic tissues. *Hum Reprod* 1991; 6: 1200–1205.



4. Bischof P, Meisser A, Campana A. Paracrine and autocrine regulators of trophoblast invasion—a review. *Placenta* 2000; 14: S55–S60.
5. Shih IM, Kurman RJ. The pathology of intermediate trophoblastic tumors and tumor-like lesions. *Int J Gynecol Pathol* 2001; 20: 31–47.
6. Mi S, Lee X, Li X-P, et al. Syncytin is a captive retroviral envelope protein involved in human placental morphogenesis. *Nature* 2000; 403: 785–789.
7. Janatpour MJ, McMaster MT, Genbacev O, et al. Id-2 regulates critical aspects of human cytotrophoblast differentiation, invasion and migration. *Development* 2000; 127: 549–558.
8. Shih IM, Kurman RJ. p63 expression is useful in the distinction of epithelioid trophoblastic and placental site trophoblastic tumors by profiling trophoblastic subpopulations. *Am J Surg Pathol* 2004; 28: 1177–1183.
9. Yang A, McKeon F. p63 and p73: p53 mimics, menaces and more. *Nat Rev Mol Cell Biol* 2000; 1: 199–207.
10. Westfall MD, Mays DJ, Sniezek JC, Pietenpol JA. The Delta Np63 alpha phosphoprotein binds the p21 and 14-3-3 sigma promoters in vivo and has transcriptional repressor activity that is reduced by Hay-Wells syndrome-derived mutations. *Mol Cell Biol* 2003; 23: 2264–2276.
11. Shih IM, Kurman RJ. Ki-67 labeling index in the differential diagnosis of exaggerated placental site, placental site trophoblastic tumor, and choriocarcinoma: a double immunohistochemical staining technique using Ki-67 and Mel-CAM antibodies. *Hum Pathol* 1998; 29: 27–33.
12. Shih IM, Schnaar RL, Gearhart JD, Kurman RJ. Distribution of cells bearing the HNK-1 epitope in the human placenta. *Placenta* 1997; 18: 667–674.
13. Fisher SJ, Damsky CH. Human cytotrophoblast invasion. *Semin Cell Biol* 1993; 4: 183–188.
14. Chassin D, Benifla JL, Delattre C, et al. Identification of genes overexpressed in tumors through preferential expression screening in trophoblasts. *Cancer Res* 1994; 54: 5217–5223.
15. Yagel S, Parhar RS, Jeffrey JJ, Lala PK. Normal nonmetastatic human trophoblast cells share in vitro invasive properties of malignant cells. *J Cell Physiol* 1988; 136: 455–462.
16. Shih IM, Hsu MY, Oldt RJ, Herlyn M, Gearhart JD, Kurman RJ. The Role of E-cadherin in the Motility and Invasion of Implantation Site Intermediate Trophoblast. *Placenta* 2002; 23: 706–715.
17. Graham CH. Effect of transforming growth factor-beta on the plasminogen activator system in cultured first trimester human cytotrophoblasts. *Placenta* 1997; 18: 137–143.
18. Graham CH, Connelly I, MacDougall JR, Kerbel RS, Stetler-Stevenson WG, Lala PK. Resistance of malignant trophoblast cells to both the anti-proliferative and anti-invasive effects of transforming growth factor- beta. *Exp Cell Res* 1994; 214: 93–99.
19. Caniggia I, Grisaru-Gravnosky S, Kuliszewsky M, Post M, Lye SJ. Inhibition of TGF-beta 3 restores the invasive capability of extravillous trophoblasts in preeclamptic pregnancies. *J Clin Invest* 1999; 103: 1641–1650.
20. Cheung AN, Shen DH, Khoo US, Wong LC, Ngan HY. p21WAF1/CIP1 expression in gestational trophoblastic disease: correlation with clinicopathological parameters, and Ki67 and p53 gene expression. *J Clin Pathol* 1998; 51: 159–162.
21. Chilosi M, Piazzola E, Lestani M, et al. Differential expression of p57kip2, a maternally imprinted cdk inhibitor, in normal human placenta and gestational trophoblastic disease. *Lab Invest* 1998; 78: 269–276.
22. Mao TT, Seidman JD, Kurman RJ, Shih IM. Cyclin E and p16 immunoreactivity in epithelioid trophoblastic tumor— an aid in differential diagnosis. *Am J Surg Pathol* 2006; 30: 1105–1110.
23. Bryant-Greenwood GD. The extracellular matrix of the human fetal membranes: structure and function. *Placenta* 1998; 19: 1–11.
24. Shih I-M, Mazur MT, Kurman RJ. Gestational trophoblastic disease, in *Blaustein's Pathology of the Female Genital Tract* (Kurman RJ, ed.), 5th ed., Springer-Verlag, New York, 2002, pp. 1193–1247.
25. Shih IM, Kurman RJ. Expression of melanoma cell adhesion molecule in intermediate trophoblast. *Lab Invest* 1996; 75: 377–388.
26. Mazur MT, Lurain JR, Brewer JI. Fatal gestational choriocarcinoma. Clinicopathologic study of patients treated at a trophoblastic disease center. *Cancer* 1982; 50: 1833–1846.
27. Grummer R, Donner A, Winterhager E. Characteristic growth of human choriocarcinoma xenografts in nude mice. *Placenta* 1999; 20: 547–553.
28. Fulop V, Mok SC, Genest DR, Szigetvari I, Cseh I, Berkowitz RS. c-myc, c-erbB-2, c-fms and bcl-2 oncoproteins. Expression in normal placenta, partial and complete mole, and choriocarcinoma. *J Reprod Med* 1998; 43: 101–110.
29. Chen CA, Chen YH, Chen TM, et al. Infrequent mutation in tumor suppressor gene p53 in gestational trophoblastic neoplasia. *Carcinogenesis* 1994; 15: 2221–2223.

30. Shi Y-F, Xie X, Zhao C-L, et al. Lack of mutation in tumour-suppressor gene p53 in gestational trophoblastic tumours. *Br J Cancer* 1996; 73: 1216–1219.
31. Fulop V, Mok SC, Genest DR, Gati I, Doszpod J, Berkowitz RS. p53, p21, Rb and mdm2 oncoproteins. Expression in normal placenta, partial and complete mole, and choriocarcinoma. *J Reprod Med* 1998; 43: 119–127.
32. Fulop V, Colitti CV, Genest D, et al. DOC-2/hDab2, a candidate tumor suppressor gene involved in the development of gestational trophoblastic diseases. *Oncogene* 1998; 17: 419–424.
33. Fulop V, Mok SC, Berkowitz RS. Molecular biology of gestational trophoblastic neoplasia: a review. *J Reprod Med* 2004; 49: 415–422.
34. Matsuda T, Sasaki M, Kato H, et al. Human chromosome 7 carries a putative tumor suppressor gene(s) involved in choriocarcinoma. *Oncogene* 1997; 15: 2773–2781.
35. Stahle-Backdhal M, Inoue M, Zedenius J, et al. Decreased expression of Ras GTPase activating protein in human trophoblastic tumors. *Am J Pathol* 1995; 146: 1073–1078.
36. Singer G, Kurman RJ, McMaster M, Shih I-M. HLA-G immunoreactivity is specific for intermediate trophoblast in gestational trophoblastic disease and can serve as a useful marker in differential diagnosis. *Am J Surg Pathol* 2002; 26 (7): 914–920.
37. Oldt RJ 3rd, Kurman RJ, Shih Ie M. Molecular genetic analysis of placental site trophoblastic tumors and epithelioid trophoblastic tumors confirms their trophoblastic origin. *Am J Pathol* 2002; 161: 1033–1037.
38. Shih I-M, Kurman RJ. Molecular basis of gestational trophoblastic diseases. *Curr Mol Med* 2002; 2: 1–12.
39. Ichikawa N, Zhai YL, Shiozawa T, et al. Immunohistochemical analysis of cell cycle regulatory gene products in normal trophoblast and placental site trophoblastic tumor. *Int J Gynecol Pathol* 1998; 17: 235–240.
40. Fisher RA, Paradinas FJ, Newlands ES, Boxer GM. Genetic evidence that placental site trophoblastic tumours can originate from a hydatidiform mole or a normal conceptus. *Br J Cancer* 1992; 65: 355–358.
41. Arima T, Imamura T, Sakuragi N, et al. Malignant trophoblastic neoplasms with different modes of origin. *Cancer Genet Cytogenet* 1995; 85: 5–15.
42. Kobel M, Pohl G, Schmitt WD, Hauptmann S, Wang TL, Shih Ie M. Activation of mitogen-activated protein kinase is required for migration and invasion of placental site trophoblastic tumor. *Am J Pathol* 2005; 167: 879–885.
43. Sebolt-Leopold JS. MEK inhibitors: a therapeutic approach to targeting the Ras-MAP kinase pathway in tumors. *Curr Pharm Des* 2004; 10: 1907–1914.
44. Holmstrom TH, Tran SE, Johnson VL, Ahn NG, Chow SC, Eriksson JE. Inhibition of mitogen-activated kinase signaling sensitizes HeLa cells to Fas receptor-mediated apoptosis. *Mol Cell Biol* 1999; 19: 5991–6002.
45. Cowley GP, Smith ME. Modulation of E-cadherin expression and morphological phenotype in the intravascular component of adenocarcinomas. *Int J Cancer* 1995; 60: 325–329.
46. Huang C, Jacobson K, Schaller MD. MAP kinases and cell migration. *J Cell Sci* 2004; 117: 4619–4628.
47. Eliceiri BP, Klemke R, Stromblad S, Cheresh DA. Integrin alphavbeta3 requirement for sustained mitogen-activated protein kinase activity during angiogenesis. *J Cell Biol* 1998; 140: 1255–1263.
48. Mansour SJ, Matten WT, Hermann AS, et al. Transformation of mammalian cells by constitutively active MAP kinase kinase. *Science* 1994; 265: 966–970.
49. Mansour SJ, Resing KA, Candi JM, et al. Mitogen-activated protein (MAP) kinase phosphorylation of MAP kinase kinase: determination of phosphorylation sites by mass spectrometry and site-directed mutagenesis. *J Biochem (Tokyo)* 1994; 116: 304–314.
50. Shih IM, Seidman JD, Kurman RJ. Placental site nodule and characterization of distinctive types of intermediate trophoblast. *Hum Pathol* 1999; 30: 687–694.
51. Shih I-M, Kurman RJ. Epithelioid trophoblastic tumor—A neoplasm distinct from choriocarcinoma and placental site trophoblastic tumor simulating carcinoma. *Am J Surg Pathol* 1998; 22: 1393–1403.
52. Fadare O, Parkash V, Carcangiu ML, Hui P. Epithelioid trophoblastic tumor: clinicopathological features with an emphasis on uterine cervical involvement. *Mod Pathol* 2006; 19: 75–82.
53. Schraml P, Bucher C, Bissig H, et al. Cyclin E overexpression and amplification in human tumours. *J Pathol* 2003; 200: 375–382.

# VI

---

## HEREDITARY ISSUES IN GYNECOLOGICAL CANCER

---

# 11

---

## Hereditary Issues In Ovarian Cancer

---

*Christina S. Chu, MD*  
*and Stephen C. Rubin, MD*

### CONTENTS

INTRODUCTION  
RISK FACTORS FOR OVARIAN CANCER  
HEREDITARY OVARIAN CANCER SYNDROMES  
HEREDITARY BREAST/OVARIAN CANCER SYNDROME  
HEREDITARY NONPOLYPOSIS COLORECTAL CANCER SYNDROME  
SCREENING FOR GENETIC SUSCEPTIBILITY  
MANAGEMENT OPTIONS  
CONCLUSIONS  
REFERENCES

---

### 1. INTRODUCTION

Epithelial ovarian cancer (EOC) is the leading cause of gynecological cancer deaths, although it accounts for only about one-quarter of all gynecological malignancies (1,2). A woman's lifetime risk of ovarian cancer is about 1 in 70. In the year 2004, the American Cancer Society estimated that 25,580 women would be diagnosed with ovarian cancer in the United States, and that 16,090 would die of this disease (3).

Although, the etiology of ovarian cancer is unknown, many associated risk factors have been identified (Table 1). Chief among these is the family history of the disease. In 1966, Lynch et al. (4) first suggested that hereditary factors contributed to a woman's risk for developing ovarian cancer. Since that time, several case-control studies (5-7) have noted an increase in risk for ovarian cancer in case of a family history of ovarian cancer as well as a personal history of breast cancer. Schildkraut and Thompson (7) examined 493 women with newly diagnosed EOC in comparison with 2465 controls. The odds ratios for ovarian cancer in first- and second-degree relatives were 3.6 (95% confidence interval [CI] 1.8-7.1) and 2.9 (95% CI 1.6-5.3), respectively. As compared with women with no family history of ovarian cancer, indicating a familial clustering of ovarian cancer cases. Similarly, a large meta-analysis performed by Stratton et al. (8), which included nearly 18,000 women showed the relative risk of ovarian cancer for women with a first-degree relative with ovarian cancer to be 3.1 (95% CI 2.6-3.7).

From: *Current Clinical Oncology: Molecular Pathology of Gynecologic Cancer*  
Edited by: A. Giordano, A. Bovicelli, and R. Kurman © Humana Press Inc., Totowa, NJ

**Table 1**  
**Risk Factors for Development of Epithelial Ovarian Cancer**

Age	>50 years
Demographics	White or European Jewish descent residence in industrialized nation (except Japan)
Reproductive factors	Early menarche, late menopause Infertility Nulliparity Breastfeeding, oral contraceptive use protective
Familial tendency	Family history <i>BRCA1</i> , <i>BRCA2</i> mutation DNA mismatch repair gene mutation
Diet	High fat intake High coffee intake Low fiber Low vitamin A
Environmental exposure	Perineal talc use Asbestos Radiation Viral infection (rubella, mumps)

In this chapter, risk factors for ovarian cancer will be discussed, with an emphasis on hereditary ovarian cancer syndromes as well as screening and management options.

## 2. RISK FACTORS FOR OVARIAN CANCER

### 2.1. Reproductive Factors

Although, the precise cause of EOC is unknown, several theories exist. The theory of “incessant ovulation” speculates that trauma to the ovarian surface epithelium during ovulation predisposes to malignant transformation. Accordingly, those with long periods of uninterrupted ovulations, such as nulliparous women (9), and those with early menarche or late menopause (10) have an increased risk for developing EOC. Higher risk has also been documented among infertile women (11–14), and some investigators have noted that drugs to induce ovulation, such as clomiphene citrate, have also been associated with an increased risk (14,15) (Table 2).

In contrast, several factors interrupting long periods of ovulation have been reported to decrease the risk of EOC. Multiparity is one such protective factor: women with one pregnancy have a relative risk of 0.6–0.8, and each subsequent pregnancy might lower the risk by about 10–15% (11,14,16–19). Breastfeeding has also been shown to confer some decrease in risk (16,20–22), although most studies show no correlation with length of lactation. In particular, use of oral contraceptives is associated with a dramatic reduction in risk. Studies have reported a decrease in risk by about 40–50% with any duration of use (23–25), but the protection is the most pronounced with long-term use. One study noted a reduction in risk of 80% with 10 years or more of use (26).

Previous hysterectomy has been associated with a lowered risk for ovarian cancer with odds ratios ranging from 0.58 to 0.78 (16–18,27–30). Annegers et al. (27) noted

**Table 2**  
**Reproductive Risk Factors for Development of Epithelial Ovarian Cancer**

<i>Factor</i>	<i>Odds ratio</i>
Parity (14)	
0 term pregnancies	1
1 term pregnancy	0.6
2 term pregnancies	0.53
3 term pregnancies	0.48
>3 term pregnancies	0.36–0.29
Early menarche (10)	
Age 13	1
Age <13	1.13
Late menopause (10)	
Age 45	1
Age 45–49	1.25
Age 50–53	1.40
Age 53	1.58
Contraception (25)	
No use	1
Any use oral contraceptives	0.6
Any use IUD	0.8
Any use barrier methods	0.8
Tubal ligation	0.5
Length of oral contraceptive use (26)	
Never	1
3–6 months	0.6
7–11 months	0.7
1–2 years	0.7
3–4 years	0.6
5–9 years	0.4
>9 years	0.2
Breastfeeding (22)	
Never	1
Ever	0.5
Infertility (13)	
<2 years unprotected intercourse	1
≥10 years unprotected intercourse	1.8
Previous hysterectomy (29)	0.58

that this reduction in risk was apparent even when one or both ovaries were preserved. This effect was present for 20–25 years (18,28). Surgical tubal ligation has been associated with reduction in ovarian cancer risk (16,17,25,28,29). Ness et al. (25) found that several methods of contraception (including oral contraceptives, intrauterine devices, barrier methods, and tubal ligation) were associated with reduced risk for ovarian cancer, even after adjustment for age, race, parity, and family history.

### 2.1.1. AGE

EOC is primarily seen in women more than the age of 50. Before the age of 30, the diagnosis is rare, even among women affected by hereditary syndromes. After the age

of 30, the incidence of ovarian cancer starts to rise. In the 40–44 year age group, the incidence is 15.7 cases per 100,000. The incidence rate peaks in the 75–79 year age group, at 57 cases per 100,000 (31). Older women tend to present with more advanced disease, and have decreased survival (32–34).

## 2.2. Demographic Factors

The incidence of ovarian cancer varies with race as well as country of origin. In the United States, ovarian cancer is more common among white women than among black women. The North American Association of Central Cancer Registries (NAACCR) data file for the period 1992–1997 contains information regarding 59,277 women with invasive ovarian cancer (35). For racial categorization, 53,496 (90.2%) were white, 3589 (6.1%) were black, 81 (0.1%) were American Indian, and 1596 (2.7%) were Asian/Pacific Islander. This analysis confirmed previous reports that white women in the United States are at a substantially higher risk for ovarian cancer compared with women of other racial and ethnic groups, especially, women of Asian/Pacific Islander ancestry. Surveillance, epidemiology, and end results (SEER) data for the period 1988–1992 showed even higher differences. The ovarian cancer rate among white women in the SEER program was 15.8 per 100,000 and that among black women was 10.2 per 100,000 compared with NAACCR rates of 13.1 per 100,000 and 9 per 100,000, respectively, for white and black women (36).

Residents of industrialized nations and affluent areas, such as Western Europe and North America have higher rates of ovarian cancer. The incidence of ovarian malignancies has been reported to be 14.9 per 100,000 for residents of Sweden and 13.3 per 100,000 for residents of the United States compared with only 4.6 per 100,000 for residents of India (37). Some postulated that differences in parity and use of oral contraceptives may in part account for the variation in ovarian cancer incidence between industrialized and nonindustrialized nations (38,39). Although, it is interesting to note that the incidence of ovarian cancer is only 2.7 per 100,000 for residents of Japan (37) and 3.2 per 100,000 for native-born Japanese immigrants in the United States, though the rate for second and third generation Japanese–Americans approximates the rate of other native-born Americans (40). Notably, the incidence of ovarian cancer among women of Jewish descent, whether born in the United States or Europe, is reported to be among the highest in the world, at 14.3 per 100,000 (37).

Racial differences affect survival rates as well. Several studies have documented higher rates of mortality among white women compared with women of other races (41–43). For the period 1973–1977, the National Cancer Institute reported the age-adjusted mortality rate to be 8.7 per 100,000 for white women compared with only 6.9 for black women (44). In a more recent evaluation of data from the NAACCR for the period 1992–1997 (45) age-adjusted ovarian cancer mortality rates per 100,000 were reported to be 7.8 for white women, 6.4 for black women, 4.2 for American Indian women, and 4.1 for women of Asian/Pacific island descent.

## 2.3. Diet

Dietary factors, such as high fat and meat intake as well as obesity have been associated with an increased risk for ovarian cancer (46). Some have suggested that these factors are associated with residence in an industrialized nation (47). Although, others

have noted that countries with higher per capital consumption of fat, such as Sweden have a higher incidence of ovarian cancer than those with lower consumption, such as Japan and China (48,49).

Coffee consumption may also play a role in risk modification. Again, epidemiological evidence has demonstrated that the highest risk of ovarian cancer occurs in Sweden, which also has the highest per capital consumption of coffee (50). A case-control study conducted by Trichopoulos et al. (51) confirmed a statistically significant association between coffee drinking and ovarian cancer, although others have found no significant correlation (49,52).

Vitamin A consumption has been noted to exert a protective effect, based on one study by Byers et al. (52), which may be because of its antioxidant effects. However, the Nurses' Health Study, encompassing more than 80,000 women, noted no correlation between intake of vitamins A, C, and E as well as fruit and vegetable intake, with ovarian cancer risk (53).

#### ***2.4. Environmental Factors***

A host of environmental exposures have been examined for their effect on ovarian cancer risk, although evidence is mixed. The introduction of chemical carcinogens, such as talc and asbestos, into the peritoneal cavity through retrograde migration from the vulva and vagina has been theorized to be associated with development of ovarian cancer. Venter et al. (54) used technetium Tc 99m-labeled human albumin microspheres to prove that particles in the lower genital tract could migrate to the ovaries. Although, talc particles have been found in both benign and malignant ovarian tumors (55,56) and occupational exposure to asbestos appears to confer a higher rate of intra-abdominal carcinomatosis (57,58), several studies have failed to find an association between these agents and the development of ovarian cancer (59-61). Modest increases in relative risk for ovarian cancer among women using perineal talc ranges from 1.6 to 1.9 (62,63).

The effect of radiation exposure is controversial. Although, Annegers et al. (27) reported an increase in relative risk by 1.8 for women exposed to radiation, others have noted no difference (58). The effect of viral infection on ovarian cancer risk is also controversial. Both rubella and influenza have been noted to play a role (9) and mumps has been the focus of more attention. Some investigators have noted mumps infection to exert a protective effect (64), whereas others have described a harmful effect (65,66). On one hand, authors have speculated that women exposed to mumps are more likely to be born into larger families with more children, and in turn, produce more children themselves, thereby lowering their risk for ovarian cancer (46,67). On the other hand, others have suggested that patients with subclinical mumps infection may suffer early ovarian failure, with associated elevation of gonadotropin levels, which may stimulate ovarian epithelial growth, leading to an elevated risk (65,66). The effect of mumps infection is not likely to be of future clinical concern in most industrialized nations given the low incidence with nearly universal vaccination programs (68,69), but mumps remains endemic in many parts of the developing world (70).

### **3. HEREDITARY OVARIAN CANCER SYNDROMES**

The greatest single risk factor for the development of EOC is a family history of breast and/or ovarian cancer. Pooled data from the SEER database at the National



Cancer Institute indicate the lifetime probability of ovarian cancer in the general population to be about 1.6%. This risk increases to 5% for women with one first-degree relative with ovarian cancer, and to 7.2% for women with two or three relatives with ovarian cancer (71). Currently, it is estimated that only approx 5–10% of ovarian cancers occur in patients with a familial predisposition (72–76). Based on studies of large families with multiple cases of ovarian cancer, two major syndromes of familial ovarian cancer have been described: hereditary breast/ovarian cancer syndrome (HBOC) and hereditary nonpolyposis colon cancer syndrome (HNPCC), or Lynch syndrome type II (67,77). In these families, cancer risk appears to be transmitted in an autosomal dominant fashion (67). Originally, site-specific ovarian cancer described as a third separate syndrome, is now felt to be a variant of HBOC in families experiencing a lack of breast cancer cases, as a result of variability of cancer risk with a specific genetic mutation, lack of accurate family history information, or chance variation. Together, HBOC and HNPCC are responsible for the vast majority of familial ovarian cancer.

#### 4. HEREDITARY BREAST/OVARIAN CANCER SYNDROME

HBOC accounts for approx 75–90% of cases of familial ovarian cancer (78). It is usually diagnosed in families with a history of breast and/or ovarian cancer affecting first- and second-degree relatives. Affected patients usually present with disease at younger ages. Although, SEER data from 1997 to 2001 indicate that the median age at diagnosis for breast cancer in the general population is 61 (79), patients with HBOC tend to present with median age in the early 40's (80). Similarly, patients in the general population with ovarian cancer present at a median age of 62 (79), compared with a mean age of 48 among patients diagnosed with EOC associated with germline mutations in *BRCA1* (81).

Families with HBOC may display multiple primary tumors. A single individual might suffer both breast and ovarian cancer, or bilateral breast cancer. Female family members may also be predisposed to colon cancer, whereas male members may also carry an increased risk of breast, prostate, and colon cancer (82).

Histological differences are apparent among ovarian cancer patients affected by HBOC. Serous histology is the predominant subtype. In a series of 53 ovarian cancer patients with germline mutations in *BRCA1* (81), 81% were noted to be of serous histology, compared with only 42% in the general population (83). Similarly, although mucinous and endometrioid types made up only 5% each, of the cases of hereditary ovarian cancer, these subtypes involved 12 and 15% of cancers in the general population, respectively. Though most cases of hereditary ovarian cancer are invasive, tumors of low malignant potential have been reported (81).

##### 4.1. *BRCA1* and *BRCA2*

In most families affected by HBOC, genetic linkage to a polymorphism on chromosome 17q21 has been found (84–86). Named *BRCA1*, this gene was finally cloned in 1994 (87), and one year later, *BRCA2* was isolated at chromosome 13q12 (88) (Table 3). Approximately, 90% of familial ovarian cancers are caused by germline mutations in the *BRCA1* gene, and most of the remaining are because of alterations in *BRCA2* (89). These genes are transmitted in an autosomal dominant fashion to offspring.

Although, *BRCA1* and *BRCA2* appear to be important in the development of familial ovarian cancer, significantly they do not appear to affect sporadic tumors. Mutations in

**Table 3**  
**Genes Involved in Familial Ovarian Cancer Syndromes**

<i>Gene</i>	<i>Location</i>	<i>Percent of ovarian cancer cases</i>	<i>Percent of ovarian cancer cases in each syndrome</i>
Hereditary breast and ovarian cancer syndrome			
<i>BRCA1</i>	17q21	4.1	75–90
<i>BRCA2</i>	13p12	3.3	10–25
Hereditary nonpolyposis colorectal cancer			
DNA mismatch repair genes:	–	2.9	–
<i>MSH2</i>	2p22-p21		30–35
<i>MLH1</i>	3p21		30–35
<i>MSH6</i>	2p16-p15		5
<i>PMS2</i>	7p22		<5
<i>PMS1</i>	2q31-q33		<1

Adapted from refs. 191–194.

*BRCA1* have been reported to occur in 3–6% of all patients with epithelial ovarian carcinoma (7,90) and in only 1 of 800 people in the general population. Even among women with a personal history of breast cancer (unselected for family history), the rate of *BRCA* mutation is approx 3–4% (91). However, the prevalence of *BRCA* mutations varies depending on ethnicity, and personal and family history (Table 4). The prevalence of mutations may be as high as 2.5% in individuals of Ashkenazi Jewish heritage (92,93). In these patients, three founder mutations, the 185delAG and 5382insC mutations in *BRCA1* and the 6174delT mutation in *BRCA2*, account for 90% of the cases of breast and ovarian cancer. Forty percent of Ashkenazi women with a personal history of ovarian cancer carry a mutation in the *BRCA1* or *BRCA2* genes (94,95). Among Ashkenazi women with breast cancer, the rate is approx 10% (96,97). Although, the mutation rate is approx 3% among women with breast cancer in the general population, those who also have a relative with ovarian cancer have a 22.8% rate of *BRCA* mutation (91). Among patients with breast cancer evaluated at a clinic for high-risk patients, those with a family history of breast and/or ovarian cancer have a 40% chance of carrying a mutation in *BRCA1* or *BRCA2* (91).

#### 4.2. Function of *BRCA1* and *BRCA2*

The exact function of the *BRCA1* and *BRCA2* genes is not known, however, current evidence suggests that they are involved in repair of DNA damage and the control of DNA replication fidelity. In support of this concept, mouse models with loss of both alleles of either *BRCA1* or *BRCA2* result in severe growth deficit and embryonic death. This has been associated with activation of the *p53* DNA damage response pathway (98–100). Similarly, in patients with *BRCA1* and *BRCA2* associated breast cancers, more than 90% display inactivation of *p53* (101–103).

In some respects, *BRCA1* and *BRCA2* function as tumor suppressor genes. Patients with germline mutations in either gene inherit functional loss of one allele, and the

**Table 4**  
**Prevalence of BRCA Mutation in Selected Populations**

<i>Population</i>	<i>Prevalence (%)</i>
General population	0.125
Ashkenazi Jewish Heritage	2.5
Ashkenazi Jewish Heritage and	
Personal history of EOC	40
Personal history of breast cancer	10
Personal history of breast cancer, diagnosis $\leq$ age 40	21
Personal history of breast cancer (unselected for family history)	
White women	3.3
Black women	0
Diagnosis < age 50 (white women)	1.4
Diagnosis $\geq$ age 50 (white women)	4.3
Personal history of breast cancer (unselected for family history), and	
Any relative with breast or ovarian cancer	6.6
Three or more relatives with breast or ovarian cancer	13.4
Any relative with ovarian cancer	22.8
Three or more relatives with both breast and ovarian cancer	33.3
Family history of breast and/or ovarian cancer, clinic-based families	40

From refs. 91–97,144.

development of cancer requires alteration of the second allele. However, unlike classical tumor suppressor genes, no disease-associated dominant mutations in *BRCA1* or *BRCA2* have been found in sporadic ovarian or breast cancers (104). These findings suggest a more complex paradigm of *BRCA* function. The model of Kinzler and Vogelstein (105) proposes that some genes act as “gatekeepers”—their mutation results in lifting of normal controls on cell division or apoptosis, allowing accelerated growth of cancer cells. In contrast, a “caretaker” gene may indirectly cause cancer when loss-of-function results in genomic instability. Cells deficient in the murine *BRCA2* analog accumulate spontaneous abnormalities in chromosome structure indicative of defective mitotic recombination (106). In vitro, similar aberrations are seen in murine cells deficient in *BRCA1* and in human cancer cells deficient in *BRCA1* or *BRCA2* (107–109). These findings suggest that the *BRCA* genes are necessary for maintaining genomic integrity. Accordingly, *BRCA* genes may function as “caretakers.” In patients with germline mutations in the *BRCA*, genes might have a predisposition to tumorigenesis, the loss of additional genes that function in concert with loss of *BRCA* function might be required for development of actual cancer.

Two principal methods of double-strand DNA break repair that exist are homologous recombination and nonhomologous end joining. Homologous recombination utilizes a complex of multiple proteins to allow strand exchange and correction in a potentially error-free process. Homologous recombination is also required to restart stalled replication forks (110). In contrast, nonhomologous end joining utilizes a sequence of various proteins to ligate broken ends, a process that is tolerant of nucleotide alterations at the site of ligation.

A key function of the *BRCA* genes appears to be maintenance of genomic integrity through homologous recombination. Although *BRCA1* has been implicated in a broad

variety of cellular pathways, including DNA replication, repair of single- and double-strand DNA breaks, cell-cycle control, apoptosis, transcription, chromatin remodeling, and protein ubiquitination, *BRCA2* is only known for its function to assist in DNA repair through regulation of *RAD51*. The interaction of the *BRCA2* and *RAD51* proteins is necessary to allow *RAD51* to facilitate homologous recombination DNA repair (111–113). In murine models, *BRCA1* deficient embryonic stem cells have been noted to display decreased homology-directed DNA repair, which can be reversed with restoration of *BRCA1* function (114,115). Although, both *BRCA1* and *BRCA2* proteins participate in aggregates of repair proteins in association with *RAD51* in the nuclei of cells exposed to ionizing radiation, *BRCA2* appears to play the more critical role. *BRCA2* appears to directly control *RAD51*, whereas *BRCA1* plays a regulatory role on both (104).

Human cells with mutated *BRCA1* have also been shown to have a defect in S phase arrest in response to ionizing radiation (116,117). This defect allows mutated cells to progress through the cell cycle. *BRCA1* deficient cells have also been shown to exhibit a cell-cycle checkpoint defect at G2/M (116,118,119). A particular mutation in *BRCA1* has been identified in which the G2/M cell-cycle checkpoint is defective, but cells are still sensitive to radiation-induced damage (120). This leads to the conclusion that both defective DNA repair and faulty cell-cycle checkpoints collaborate in *BRCA* mutant cells to produce chromosomal abnormalities.

Impaired *BRCA1* or *BRCA2* function may promote tumorigenesis through impaired homologous recombination in cooperation with other key cellular processes. Defects in homologous recombination might lead to an error-prone process or shunting of repair into a nonhomologous end joining pathway, which is inherently error-prone. However, despite progress in elucidating the complex functions of *BRCA1* and *BRCA2*, it remains unclear why mutation related cancer susceptibility is manifested in only specific tissues, such as breast and ovary. Proliferation of breast and ovarian epithelium may engender higher levels of DNA damage. Alternatively, *BRCA* deficiency might make breast or ovarian cells more sensitive to mutagens, such as estrogen metabolites. A third hypothesis is that loss of a second *BRCA* allele may be more likely in tissues, such as breast and ovary, where periods of increased proliferation alternate with prolonged periods of quiescence (when *BRCA* function may be unnecessary). Thus, leading to accumulation of cells lacking both normal *BRCA* alleles.

### 4.3. Penetrance

Mutations in *BRCA1* and *BRCA2* genotype do not uniformly produce a cancer phenotype. Estimates of risk for carriers vary depending on the population examined, patient age, and specific mutation involved. Overall in high-risk, clinic-based families, high penetrance of *BRCA1* mutations convey more than 90% lifetime risk of developing either breast or ovarian cancer (78). For *BRCA2*, the risk of developing either breast or ovarian cancer by the age of 70 has been reported to be 88% (121).

For *BRCA*-associated breast cancer, reported risk ranges widely from 35 to 75% (97,122–124). In large families with multiple cases of breast cancer carrying mutations in *BRCA1*, studied by the Breast Cancer Linkage Consortium, the risk of developing breast cancer was more than 50% by the age of 50, and 82% by the age of 70, compared with only 11% in the general population (78). In comparison, the risk for *BRCA2*

carriers reached 28% by the age of 50, and 84% by the age of 70 (121). The risk of cancer in mutation carriers in the general population is lower, yielding an overall penetrance for breast cancer of about 50–70% (123).

For ovarian cancer, the reported lifetime risk for mutation carriers ranges from 15 to 60% (78,121,123,125). For those in high-risk families carrying *BRCA1* mutations, the risk for developing ovarian cancer by the age of 70 has been estimated to be 44–63%, compared with only 1.4% in the general population (78). The risk for *BRCA2* carriers from similar families was 27% by age 70 (121). Given that penetrance is lower in mutation carriers from the general population, studies of women in the Ashkenazi Jewish population selected for no family history has revealed risk for ovarian cancer to be 16–37% (123,126).

#### 4.4. Clinical Course

Unlike *BRCA*-associated breast cancer, which has a poorer prognosis with lower levels of estrogen receptor expression, lower levels of histological differentiation, higher frequency of lymph node metastases, and shorter disease-free survival (96,127), *BRCA*-associated ovarian cancer seems to have a more favorable prognosis. Rubin et al. (81) examined 53 patients with germline mutations in *BRCA1* in comparison with sporadic age- and stage-matched controls. The investigators noted a significantly improved median survival for advanced stage patients with *BRCA1* mutations to be 77 months compared with only 29 months for patients with sporadic cancers ( $p < 0.001$ ). Boyd et al. (95) noted similar findings in their report of 88 Jewish ovarian cancer patients with either *BRCA1* or *BRCA2* mutations. Compared with controls, mutation carriers were noted to have longer median time to recurrence (7 months vs 14 months,  $p < 0.001$ ) and increased survival ( $p = 0.004$ ). After adjustment for age and disease residual, *BRCA* mutation status was noted to be an independent prognostic factor among patients with stage III tumors, associated with a reduction in relative risk of death of 25% in comparison with sporadic cancers.

### 5. HEREDITARY NONPOLYPOSIS COLORECTAL CANCER SYNDROME

HNPCC, or Lynch II syndrome occurs in families affected by a combination of early-onset colon cancer and cancers of the ovary, endometrium, stomach, small bowel, pancreas, bile ducts, skin (sebaceous adenomas and carcinomas), and urinary tract. HNPCC accounts for only 2% of cases of hereditary ovarian cancer, and 5% of all colorectal cancers. Cancer susceptibility in these families is transmitted in an autosomal dominant fashion, and penetrance varies. By the age of 65, approx 70% of carriers will develop colorectal cancer (128,129). Affected members tend to present with early-onset colorectal cancers (diagnosis before age 45), and have a tendency toward proximal tumors. Synchronous and metachronous cancers are common.

Following colorectal cancer, endometrial cancer is the second most common malignancy in these families. In fact, in a large family-based study conducted by Aarnio et al. (130) the incidence of endometrial cancer was more than the incidence of colorectal cancer in women (60% vs 54%, respectively). A population-based study noted similar results (42% vs 30%, respectively) (131). Patients with HNPCC incur a 3.5–8-fold increased risk of ovarian cancer (132,133), and lifetime risks vary between 9 and 12% (129,130). Ovarian cancer risk is particularly associated with mutations in *MSH2* (132).

Other noncolonic primaries occur with varying frequencies. Lifetime risks for gastric, biliary, and urinary tract primaries are 13–19%, 18%, and 10%, respectively (129,130). For other tumors, the risk is less than 4% (130). The majority of HNPCC carriers who develop colon cancer will also develop a second primary, usually a synchronous or metachronous colon cancer, or endometrial cancer. After the diagnosis of colorectal cancer, the risk of any metachronous cancer reached 90%. After the diagnosis of endometrial cancer, the risk reached 75%. The most common second tumor was a new colorectal cancer or endometrial cancer (129).

### 5.1. DNA Mismatch Repair Genes

HNPCC has been linked to multiple genetic mutations in the DNA mismatch repair (MMR) genes (134,135). One function of the MMR genes is to detect and correct mismatched nucleotides in DNA strands. Loss-of-function of these genes leads to error-prone DNA replication and microsatellite instability. Eventually, buildup of genetic replication errors in oncogenes and tumor suppressor genes leads to carcinogenesis. Indeed, Risinger et al. (136) detected microsatellite instability in 75% of endometrial carcinomas associated with HNPCC vs only 17% of sporadic cancers.

Five mutations in the MMR genes have been linked to HNPCC (Table 3). Two of these, *MLH1* on chromosome 3 and *MSH2* on chromosome 2, account for the vast majority of cases, 45 and 49%, respectively (137). Most of the remainder occurs in *PMS2* on chromosome 7, whereas mutations in *PSM1* and *MSH6* are noted only sporadically. Little is known about the prevalence of MMR gene mutations, but prevalence appears to vary widely. Carrier frequencies are usually calculated by screening individuals with colon cancer for mutations in various MMR genes. Samowitz et al. (138) conducted a population-based study of 1066 individuals from Utah and California with colon cancer and identified seven pathogenical mutations in *MSH2* and *MLH1*. Thus, leading to a prevalence of 0.86% after adjustment for availability of germline DNA. Percesepe et al. examined 336 consecutive cases of colon cancer in Italy and noted only one germline mutation (in *MSH2*), yielding a prevalence of 0.3% (139). In the largest study to date, Salovaara et al. (140) examined 1044 consecutive cases of colon cancer in Finland and noted 28 cases of mutation-positive HNPCC, predicting a rate of 2.7%, more than three times that found in the United States study.

## 6. SCREENING FOR GENETIC SUSCEPTIBILITY

Because of the low prevalence of mutations in the general population and the cost of testing, genetic screening is not appropriate for all individuals. The first step in risk assessment is accurate family history. This essential, cost-effective tool allows primary care physicians to initiate evaluation (141). Information on three generations for both maternal and paternal relatives should be gathered, including race, age, cancer type, age at diagnosis, and age at death. Information should be updated at each visit, as family history is not static. Based on history, patients at elevated risk may be referred for additional evaluation by an oncologist or cancer geneticist. In 1996, the American Society of Clinical Oncology (ASCO) recommended testing for genetic susceptibility only when: “(1) the person has a strong family history of cancer or very early-age onset of disease; (2) the test can be adequately interpreted; and (3) the results will influence the medical management of the patient or family member” (142). Before

DNA testing, all patients should undergo genetic counseling to carefully detail potential risks and benefits.

For patients at risk for HBOC, the ASCO panel suggested that testing is most likely to be of value for patients with at least a 10% probability of carrying a mutation in *BRCA1* or *BRCA2*. A summary of these patients is detailed in Table 5. Aside from identifying specific subsets of patients based on personal and family history, some investigators have developed risk assessment models to detect potential patients who may benefit from testing. Frank et al. (143) developed a statistical model to predict the probability of *BRCA1* or *BRCA2* mutation for women diagnosed with breast cancer before the age of 50 by utilizing personal and family history information. Couch et al. (144) incorporated the average age of breast cancer diagnosis in the family, and whether the family history included breast cancer only or breast and ovarian cancer to predict the probability of a *BRCA1* mutation. In both models, the likelihood of mutation rises with any history of ovarian cancer.

For individuals at risk for HNPCC mutations, the Amsterdam and Bethesda criteria are used to identify those likely to benefit from genetic screening (145). The Bethesda criteria stipulate that individuals with either two relatives (in small families) or two first-degree relatives with colon cancer, combined with a third relative with early-onset colon cancer or endometrial cancer should undergo genetic testing. The Amsterdam criteria recommend testing for individuals meeting any of the following conditions:

1. A family history of two or more successive generations affected by colorectal cancer,
2. One or more relatives diagnosed with colorectal cancer before the age of 50,
3. Colon cancer diagnosed in at least three relatives (one must be related to the other two), or
4. An increased incidence of other cancers (such as ovary, uterus, stomach, urinary tract, small bowel, and bile duct).

After genetic testing, careful counseling is necessary to interpret the meaning of both positive and negative test results. A positive result indicates that an individual carries a potential disease-causing mutation. In families where a specific mutation has been identified, the benefit for testing family members is clear. The family members testing negative for the mutation may be reassured that their risk, although not zero, is not elevated more than that in the general population. A negative test result must be carefully interpreted. False-negative results may occur when an individual's mutation arises in a gene that was not tested, or the mutation is not detected by polymerase chain reaction techniques (in the case of a mutation in a noncoding region or a large deletion). In cases, where multiple family members are affected, a single member's negative test should not preclude testing other relatives because a given individual might simply have suffered a case of sporadic cancer. As negative results are not necessarily informative in families without a specific defined mutation, physicians should still consider appropriate clinical management options for patients at high-risk by history, but with negative test results.

## 7. MANAGEMENT OPTIONS

### 7.1. Screening

Even though no method exists which can reliably identify patients with early ovarian cancer (146), attempts have been made to screen populations of women at elevated risk. In 1995, the National Institutes of Health Consensus Conference on Ovarian

**Table 5**  
**Individuals Likely to Benefit From BRCA Mutation Testing**

---

Ashkenazi Jewish heritage with personal or family history of breast or ovarian cancer
Personal history of breast cancer and family history of breast cancer < age 50
Personal history of breast cancer and family history of two or more cases of breast cancer
Personal history of breast cancer and family history of ovarian cancer
Personal history of ovarian cancer < age 50
Personal or family history of bilateral breast cancer
Family history of one first-degree relative with both breast and ovarian cancer
Family history of two or more cases of breast cancer < age 50
Family history of two or more cases of ovarian cancer
Family history of male breast cancer
First-degree relative with BRCA1 or BRCA2 mutation

---

Adapted from refs. 123,142,195–197.

Cancer (147) recommended a combination of annual or semiannual bimanual pelvic examination, transvaginal ultrasonography (TVUS), and serum CA-125 measurement to screen high-risk women. In 1997, the Cancer Genetics Studies Consortium recommended annual or semiannual screening of women with known BRCA mutations using TVUS and CA-125 testing starting at the age of 25–35 (145). Another strategy, the Risk of Ovarian Cancer Algorithm (ROCA), utilizes yearly longitudinal CA-125 measurements in a computerized Bayesian algorithm to calculate risk of ovarian cancer (148). Each patient's CA-125 levels are compared with known patterns for patients with ovarian cancer and controls. This strategy is currently being evaluated clinically in small trials in the United States and the United Kingdom.

Despite multiple screening strategies, no methods have been shown to reduce morbidity or mortality (147). The use of TVUS remains problematic as a screening modality, although small, potentially curable, ovarian tumors may be detected (149), TVUS might miss primary peritoneal cancers or ovarian cancers with normal sized ovaries. Also, TVUS is unable to reliably distinguish the difference between benign and malignant tumors, sometimes leading to unnecessary surgical intervention. CA-125 is the most commonly used tumor marker to screen for ovarian cancer, but the value is elevated in only 80% of cases. A prospective study of more than 20,000 women indicated a specificity of 99%, but a sensitivity of only 71% (150). For patients with the best potential for cure, those with stage I disease, only half present with elevated CA-125 levels (151) and again, false-positives may lead to unneeded surgical intervention.

For patients with elevated risk for breast cancer, BRCA mutation carriers are recommended to perform monthly breast self examinations beginning at the age of 18, to undergo annual or semiannual clinical breast examination and to obtain annual mammography beginning at the age of 25–35 (145). Patients with MMR gene mutations are recommended to undergo colonoscopy every 1–3 years beginning at the age of 25, and annual endometrial biopsy and/or TVUS for endometrial stripe evaluation beginning at the age of 25–35 (128). Surveillance options are summarized in Table 6.

Despite the well-documented increased risk of cancer, many women do not adhere to recommendations for surveillance. A recent study by Botkin et al. (152) noted that



**Table 6**  
**Surveillance Options for High-Risk Women**

<i>Disease</i>	<i>Recommendations</i>
Ovarian cancer	<ol style="list-style-type: none"> <li>1. Annual or semiannual bimanual pelvic examination</li> <li>2. Annual or semiannual transvaginal ultrasound</li> <li>3. Annual or semiannual CA-125 measurement starting at age 25–35</li> </ol>
Breast cancer	<ol style="list-style-type: none"> <li>1. Monthly breast self exam starting age 18</li> <li>2. Annual or semiannual clinical breast exam</li> <li>3. Annual mammography starting age 25–35</li> </ol>
Colon cancer	Colonoscopy every 1–3 years beginning at age 25
Endometrial cancer	<ol style="list-style-type: none"> <li>1. Annual endometrial biopsy</li> <li>2. Annual transvaginal ultrasound starting at age 25–35</li> </ol>

only 26% of women obtained a TVUS in the first year after testing positive for a mutation in the BRCA genes. This rate dropped to 11% in the second year. Similarly, even less invasive CA-125 testing was only utilized by 32% of women in the first year, and 37% of women in the second year after testing positive. In contrast, increased screening for breast cancer appears to be more acceptable. The authors noted that 71% of women obtained a mammogram within 2 years of mutation testing, and that more than 80% followed recommendations for clinical and breast self examination.

Future directions for screening of high-risk women will likely focus on the identification of biomarkers for early cancer detection and improved risk assessment. Several promising strategies under active investigation include differential protein and gene expression. Petricoin et al. (153) generated proteomic spectra using mass spectroscopy for 50 patients with ovarian cancer and 50 controls. These spectra were analyzed to identify a proteomic pattern that discriminated cancer from noncancer. The identified pattern was used to classify a test set of 116 samples. The investigators' algorithm correctly identified all 50 cases of ovarian cancer (including all 18 stage I cases) in the test set. Of the 66 control cases, 63 were correctly classified by the algorithm, yielding a sensitivity of 100%, specificity of 95%, and positive predictive value of 94%. The high positive predictive value indicates that this technique may be promising for high-risk patients, but given the low disease incidence in the general population, it may not yet be advisable for general screening.

### 7.2. Chemoprophylaxis

In addition to increased surveillance, several agents are under investigation for prevention of ovarian cancer. Although, oral contraceptive use was noted in 1979 to reduce the risk of ovarian cancer in the general population by as much as 40% (23), risk reduction in *BRCA1* and *BRCA2* mutation carriers was not examined until 1998. Narod et al. (24) compared 207 women with *BRCA1* and *BRCA2* mutation related ovarian cancer with 161 of their cancer-free sisters. Any past use of oral contraceptives was associated with a 50% reduction in ovarian cancer risk, although no difference in breast cancer risk was noted. Other researchers have found conflicting results. Modan et al. (154) conducted a large population-based case-control study comparing 840 Jewish women

in Israel with ovarian cancer and 751 controls. In this study, oral contraceptive use only appeared to reduce risk in women without *BRCA* mutations; among mutation carriers, the reduction in risk was only 0.2% per year of use. Any protective effects of oral contraceptives may not be solely because of ovulation suppression, as progestin only formulations (which do not suppress ovulation) have been observed to be as effective as combination preparations (155). Also, oral contraceptives with higher doses of progestin seem to confer a higher level of protection than those with lower doses (156). Evidence in primate models suggests that progesterone may mediate apoptosis of ovarian epithelial cells as well as changes in TGF- $\beta$  production (157,158). The results of large prospective chemoprevention trials are necessary to resolve the question of the effectiveness of oral contraceptives for ovarian cancer risk reduction. However, it appears that mutation carriers may use premenopausal oral contraceptives without increase in their breast cancer risk.

Several other agents are under investigation for chemoprevention. Epidemiological evidence has previously suggested a role for retinoids in the prevention of ovarian cancer (52,159). Fenretinide (N-4-hydroxyphenyl retinamide) has been used in treatment of breast cancer, and may reduce risk for ovarian cancer. In vitro, the agent has been noted to decrease proliferation and increase apoptosis in ovarian epithelium and cancer cell lines (160–163). In a study of patients with breast cancer randomized to receive fenretinide or placebo for five years as a means of possible chemoprophylaxis for contralateral breast cancer, patients in the fenretinide group were noted to have no cases of ovarian cancer, vs 6 cases in the control arm during the period of active treatment ( $p = 0.03$ ), although this effect was not observed after the drug was ceased (164). Gynecological Oncology Group trial No. 190 is currently underway to evaluate the benefit of fenretinide in high-risk women after prophylactic oophorectomy.

Vitamin D is also under study as a potential preventative agent. Ovarian cancer incidence has been noted to vary with latitude, and with lower rates in areas of higher ultraviolet exposure, the primary source of vitamin D (165,166). Lefkowitz et al. (167) investigated the association between average annual sunlight energy and age-specific ovarian cancer mortality rates and noted that the ovarian cancer mortality rate was inversely proportional to mean annual intensity of sunlight. These results were statistically significant on both univariate analysis and logistic regression. Prostate cancer mortality has also been noted to vary inversely with ultraviolet radiation (168), and the effects of vitamin D have been studied in more detail in this disease. Corder et al. (169) noted the level of 1,25-dihydroxyvitamin D, a metabolite of vitamin D, to be an important predictor of risk for palpable and anaplastic prostate tumors in men aged 57 or older. Unfortunately, the clinical use of pharmacological doses of vitamin D is limited by its hypercalcemic effects. Less calcemic vitamin D analogs have been studied by Schwartz et al. (170) in vitro and were found to exert significant antiproliferative activity on multiple prostate carcinoma cell lines. Studies of vitamin D as a chemopreventative agent are underway in animal models and as part of the Women's Health Initiative in relation to fracture and colon cancer risk, although data gathered will likely provide insight into ovarian cancer incidence as well (171).

Epidemiological evidence suggests that nonsteroidal anti-inflammatory drugs (NSAIDs) decrease the risk of ovarian cancer as well as other tumors (172–176). Rosenberg et al. performed a case-control study of 780 women with EOC compared

with 2570 controls and noted a statistically significant decrease in ovarian cancer risk with use of NSAIDs, four days or more a week for at least 5 years (174). Although, the basis for a protective effect is not well delineated, *in vitro* COX-2 inhibitors have been found to decrease cell proliferation, whereas increasing apoptosis in ovarian cancer cell lines (177), and limiting COX-2 catalyzed production of prostaglandins with subsequent effects of proliferation, apoptosis, and angiogenesis (178,179). Others have proposed that COX-2 inhibition might lead to decreased loss of ovarian surface epithelium basement membrane and reduction of malignant transformation (180). Additional studies are necessary for evaluation of these agents as chemopreventatives for ovarian cancer.

### 7.3. Prophylactic Surgery

To date, prophylactic oophorectomy has been the most definitive method for preventing ovarian cancer in high-risk women, and recent evidence shows that the procedure might also decrease the risk of breast cancer. In 2002, Rebbeck et al. (181) examined 551 women with germline mutations in *BRCA1* and *BRCA2*, of which 259 had and 292 matched controls had not undergone prophylactic oophorectomy. Among the women undergoing surgery, six (2.3%) were diagnosed with occult stage I ovarian cancer at the time of surgery, and 2 women (0.8%) were later diagnosed with primary peritoneal cancer. In contrast, 58 women (19.9%) out of the women in the control group were diagnosed with ovarian cancer after a mean follow-up of 8.8 years. Excluding the 6 diagnosed with occult cancer, prophylactic oophorectomy significantly decreased the risk of ovarian or primary peritoneal cancer by 96%. In addition, 99 women were studied for the risk of developing breast cancer; 21 women (21.2%) developed breast cancer from among the women undergoing prophylactic surgery, compared with 60 (42.3%) controls, showing a 53% reduction in risk. A similar study by Kauff et al. (182) prospectively followed 170 women, age 35 or older, with either *BRCA1* or *BRCA2* mutations. Among the 98 women who chose prophylactic oophorectomy, breast cancer was diagnosed in 3 (3%) and primary peritoneal cancer was diagnosed in 1 (1%) at a mean follow-up of 24.2 months. In contrast, of the 72 women who chose surveillance, breast cancer was diagnosed in 8 (11%), and ovarian or primary peritoneal cancer was diagnosed in 5 (7%). Prophylactic oophorectomy decreased the risk of subsequent ovarian/primary peritoneal cancer by 85%, and the risk of breast cancer by 70%.

Prophylactic oophorectomy may be performed laparoscopically on an outpatient basis in the vast majority of women, with low morbidity and mortality. However, aside from perioperative risks and issues associated with early menopause, patients should be carefully counseled that the procedure might not be entirely protective. Because primary peritoneal cancer has been reported to occur in 0.8–11% of high-risk women even after prophylactic oophorectomy (67,181–183) thorough exploration of the pelvic and abdominal cavity should be performed at the time of surgery. Also, complete meticulous histological assessment of the ovaries should be performed, in order to exclude the presence of occult malignancy, which has been reported to occur in 2–4% of women undergoing prophylactic oophorectomy (181,184–186). Given the documented increased risk of fallopian tube carcinoma in women with *BRCA1* and *BRCA2* mutations, the surgeon should take care to remove the entire fallopian tube. Without performing hysterectomy or corneal resection, a small interstitial portion of fallopian tube will always be retained, although this is felt to contribute negligible risk given

that no cases of fallopian tube carcinoma after prophylactic salpingo-oophorectomy have been reported.

As no consistent data exist to support the relationship of *BRCA1* and *BRCA2* mutations to endometrial cancer, current recommendations for surgical prophylaxis do not include routine hysterectomy. However, women undergoing tamoxifen therapy for a previous diagnosis of breast cancer might be considered candidates for hysterectomy. Given that women with breast cancer may be treated for five years, and that tamoxifen has been well documented to increase the risk of endometrial cancer (187,188) as well as cause subendothelial thickening, abnormal uterine bleeding, and endometrial polyps, these women may consider hysterectomy at the time of prophylactic salpingo-oophorectomy after careful consultation with their physician. Women with HNPCC should be offered both prophylactic oophorectomy and hysterectomy to decrease the risk of future gynecological malignancy.

Compared with intensive surveillance, prophylactic oophorectomy appears to be preferred by women at high-risk for ovarian cancer (152,189,190). Tiller et al. (190) noted a high level of satisfaction among women undergoing the procedure, accompanied by decreased levels of anxiety. Given the lack of clearly effective surveillance regimens, as well as the usually manageable side effects of early menopause, the clear reduction in ovarian cancer risk provided by surgical extirpation provides a strong argument for prophylactic oophorectomy in high-risk women.

## 8. CONCLUSIONS

Though extensive research has managed to identify risk factors for the development of ovarian cancer, other than prophylactic surgery, clearly effective management strategies remain elusive. Better approaches to early detection, cancer prevention, risk modification, and surveillance are desperately needed for women affected by hereditary ovarian cancer as well as for all women.

## REFERENCES

1. Tortolero-Luna G, Mitchell MF, Rhodes-Morris HE. Epidemiology and screening of ovarian cancer. *Obstet Gynecol Clin NA* 1994; 21: 1–23.
2. Baker TR, Piver MS. Etiology, biology, and epidemiology of ovarian cancer. *Seminars Surg Oncol* 1994; 10: 242–248.
3. Jemal A, Tiwari RC, Murray T, et al. Cancer statistics 2004. *CA Cancer J Clin* 2004; 54(1): 8–29.
4. Lynch HT, Shaw MW, Magnuson CW, Larsen AL, Krush AJ. Hereditary factors in cancer. Study of two large midwestern kindreds. *Arch Intern Med* 1966; 117(2): 206–212.
5. Koch M, Gaedke H, Jenkins H. Family history of ovarian cancer patients: a case-control study. *Int J Epidemiol* 1989; 18(4): 782–785.
6. Hartge P, Schiffman MH, Hoover R, McGowan L, Leshner L, Norris HJ. A case-control study of epithelial ovarian cancer. *Am J Obstet Gynecol* 1989; 161(1): 10–16.
7. Schildkraut JM, Thompson WD. Familial ovarian cancer: a population-based case-control study. *Am J Epidemiol* 1988; 128(3): 456–466.
8. Stratton JF, Pharoah P, Smith SK, Easton D, Ponder BA. A systematic review and meta-analysis of family history and risk of ovarian cancer. *Br J Obstet Gynaecol* 1998; 105(5): 493–499.
9. McGowan L, Parent L, Lednar W, Norris HJ. The woman at risk for developing ovarian cancer. *Gynecol Oncol* 1979; 7(3): 325–344.
10. Parazzini F, La Vecchia C, Negri E, Gentile A. Menstrual factors and the risk of epithelial ovarian cancer. *J Clin Epidemiol* 1989; 42(5): 443–448.
11. Joly DJ, Lilienfeld AM, Diamond EL, Bross ID. An epidemiologic study of the relationship of reproductive experience to cancer of the ovary. *Am J Epidemiol* 1974; 99(3): 190–209.

12. Nasca PC, Greenwald P, Chorost S, Richart R, Caputo T. An epidemiologic case-control study of ovarian cancer and reproductive factors. *Am J Epidemiol* 1984; 119(5): 705–713.
13. Whittemore AS, Wu ML, Paffenbarger RS Jr, et al. Epithelial ovarian cancer and the ability to conceive. *Cancer Res* 1989; 49(14): 4047–4052.
14. Whittemore AS, Harris R, Itnyre J. Characteristics relating to ovarian cancer risk: collaborative analysis of 12 US case-control studies. IV. The pathogenesis of epithelial ovarian cancer. Collaborative Ovarian Cancer Group. *Am J Epidemiol* 1992; 136(10): 1212–1220.
15. Rossing MA, Daling JR, Weiss NS, Moore DE, Self SG. Ovarian tumors in a cohort of infertile women. *N Engl J Med* 1994; 331(12): 771–776.
16. Booth M, Beral V, Smith P. Risk factors for ovarian cancer: a case-control study. *Br J Cancer* 1989; 60(4): 592–598.
17. Hankinson SE, Hunter DJ, Colditz GA, et al. Tubal ligation, hysterectomy, and risk of ovarian cancer. A prospective study. *JAMA* 1993; 270(23): 2813–2818.
18. Risch HA, Marrett LD, Howe GR. Parity, contraception, infertility, and the risk of epithelial ovarian cancer. *Am J Epidemiol* 1994; 140(7): 585–597.
19. Wu ML, Whittemore AS, Paffenbarger RS Jr, et al. Personal and environmental characteristics related to epithelial ovarian cancer. I. Reproductive and menstrual events and oral contraceptive use. *Am J Epidemiol* 1988; 128(6): 1216–1227.
20. Rosenblatt KA, Thomas DB. Lactation and the risk of epithelial ovarian cancer. The WHO Collaborative Study of Neoplasia and Steroid Contraceptives. *Int J Epidemiol* 1993; 22(2): 192–197.
21. Siskind V, Green A, Bain C, Purdie D. Breastfeeding, menopause, and epithelial ovarian cancer. *Epidemiology* 1997; 8(2): 188–191.
22. Tung KH, Goodman MT, Wu AH, et al. Reproductive factors and epithelial ovarian cancer risk by histologic type: a multiethnic case-control study. *Am J Epidemiol* 2003; 158(7): 629–638.
23. Casagrande JT, Louie EW, Pike MC, Roy S, Ross RK, Henderson BE. “Incessant ovulation” and ovarian cancer. *Lancet* 1979; 2(8135): 170–173.
24. Narod SA, Risch H, Moslehi R, et al. Oral contraceptives and the risk of hereditary ovarian cancer. Hereditary Ovarian Cancer Clinical Study Group. *N Engl J Med* 1998; 339(7): 424–428.
25. Ness RB, Grisso JA, Vergona R, Klapper J, Morgan M, Wheeler JE. Oral contraceptives, other methods of contraception, and risk reduction for ovarian cancer. *Epidemiology* 2001; 12(3): 307–312.
26. The reduction in risk of ovarian cancer associated with oral-contraceptive use. The Cancer and Steroid Hormone Study of the Centers for Disease Control and the National Institute of Child Health and Human Development. *N Engl J Med* 1987; 316(11): 650–655.
27. Annegers JF, Strom H, Decker DG, Dockerty MB, O’Fallon WM. Ovarian cancer: incidence and case-control study. *Cancer* 1979; 43(2): 723–729.
28. Green A, Purdie D, Bain C, et al. Tubal sterilisation, hysterectomy and decreased risk of ovarian cancer. Survey of Women’s Health Study Group. *Int J Cancer* 1997; 71(6): 948–951.
29. Rosenblatt KA, Thomas DB. Reduced risk of ovarian cancer in women with a tubal ligation or hysterectomy. The World Health Organization Collaborative Study of Neoplasia and Steroid Contraceptives. *Cancer Epidemiol Biomarkers Prev* 1996; 5(11): 933–935.
30. Loft A, Lidegaard O, Tabor A. Incidence of ovarian cancer after hysterectomy: a nationwide controlled follow up. *Br J Obstet Gynaecol* 1997; 104(11): 1296–1301.
31. Amos CI, Struwing JP. Genetic epidemiology of epithelial ovarian cancer. *Cancer* 1993; 71(Suppl 2): 566–572.
32. McGuire V, Jessor CA, Whittemore AS. Survival among US women with invasive epithelial ovarian cancer. *Gynecol Oncol* 2002; 84(3): 399–403.
33. Averette HE, Janicek MF, Menck HR. The National Cancer Data Base report on ovarian cancer. American College of Surgeons Commission on Cancer and the American Cancer Society. *Cancer* 1995; 76(6): 1096–1103.
34. Kosary CL. FIGO stage, histology, histologic grade, age and race as prognostic factors in determining survival for cancers of the female gynecological system: an analysis of 1973–1987 SEER cases of cancers of the endometrium, cervix, ovary, vulva, and vagina. *Semin Surg Oncol* 1994; 10(1): 31–46.
35. Goodman MT, Howe HL, Tung KH, Hotes J, Miller BA, Coughlin SS, Chen VW. Incidence of ovarian cancer by race and ethnicity in the United States, 1992–1997. *Cancer* 2003; 97(Suppl 10): 2676–2685.
36. Miller BA, Kolonel LN, Bernstein L, et al. (eds.). Racial/Ethnic Patterns of Cancer in the United States 1988–1992 (NIH Publication No. 96-4104). Bethesda, MD, National Institutes of Health, National Cancer Institute; 1996.

37. Lingeman CH. Environmental factors in the etiology of carcinoma of the human ovary: a review. *Am J Ind Med* 1983; 4(1-2): 365-379.
38. Beral V, Fraser P, Chilvers C. Does pregnancy protect against ovarian cancer? *Lancet* 1978; 1(8073): 1083-1087.
39. dos Santos Silva I, Swerdlow AJ. Recent trends in incidence of and mortality from breast, ovarian and endometrial cancers in England and Wales and their relation to changing fertility and oral contraceptive use. *Br J Cancer* 1995; 72(2): 485-492.
40. Buell P, Dunn JE. Cancer mortality among the Japanese Issei and Nisei of California. *Cancer* 1965; 18: 656-664.
41. Landis SH, Murray T, Bolden S, Wingo PA. Cancer statistics, 1999. *CA Cancer J Clin* 1999; 49(1): 8-31.
42. Piffath TA, Whiteman MK, Flaws JA, Fix AD, Busht TL. Ethnic differences in cancer mortality trends in the US, 1950-1992. *Ethn Health* 2001; 6(2): 105-119.
43. Oriol KA, Hartenbach EM, Remington PL. Trends in United States ovarian cancer mortality, 1979-1995. *Obstet Gynecol* 1999; 93(1): 30-33.
44. Roush GC, Holford TR, Schymura MJ, White C. Cancer risk and incidence trends: the Connecticut perspective. Hemisphere, New York, 1987; 268-277.
45. Howe HL, Tung KH, Coughlin S, Jean-Baptiste R, Hotes J. Race/ethnic variations in ovarian cancer mortality in the United States, 1992-1997. *Cancer* 2003; 97(Suppl 10): 2686-2693.
46. Greene MH, Clark JW, Blayney DW. The epidemiology of ovarian cancer. *Semin Oncol* 1984; 11(3): 209-226.
47. Rose DP, Boyar AP, Wynder EL. International comparisons of mortality rates for cancer of the breast, ovary, prostate, and colon, and per capita food consumption. *Cancer* 1986; 58(11): 2363-2371.
48. Li FP, Shiang EL. Cancer mortality in China. *J Natl Cancer Inst* 1980; 65(2): 217-221.
49. Cramer DW, Welch WR, Hutchison GB, Willett W, Scully RE. Dietary animal fat in relation to ovarian cancer risk. *Obstet Gynecol* 1984; 63(6): 833-838.
50. Stocks P. Cancer mortality in relation to national consumption of cigarettes, solid fuel, tea and coffee. *Br J Cancer* 1970; 24(2): 215-225.
51. Trichopoulos D, Papapostolou M, Polychronopoulou A. Coffee and ovarian cancer. *Int J Cancer* 1981; 28(6): 691-693.
52. Byers T, Marshall J, Graham S, Mettlin C, Swanson M. A case-control study of dietary and nondietary factors in ovarian cancer. *J Natl Cancer Inst* 1983; 71(4): 681-686.
53. Fairfield KM, Hankinson SE, Rosner BA, Hunter DJ, Colditz GA, Willett WC. Risk of ovarian carcinoma and consumption of vitamins A, C, and E and specific carotenoids: a prospective analysis. *Cancer* 2001; 92(9): 2318-2326.
54. Venter PF. Ovarian epithelial cancer and chemical carcinogenesis. *Gynecol Oncol* 1981; 12(3): 281-285.
55. Graham J, Graham R. Ovarian cancer and asbestos. *Environ Res* 1967; 1(2): 115-128.
56. Henderson WJ, Hamilton TC, Griffiths K. Talc in normal and malignant ovarian tissue. *Lancet* 1979; 1(8114): 499.
57. Keal EE. Asbestosis and abdominal neoplasms. *Lancet* 1960; 2: 1211-1216.
58. Newhouse ML, Pearson RM, Fullerton JM, Boesen EA, Shannon HS. A case control study of carcinoma of the ovary. *Br J Prev Soc Med* 1977; 31(3): 148-153.
59. Hartge P, Hoover R, Leshner LP, McGowan L. Talc and ovarian cancer. *JAMA* 1983; 250(14): 1844.
60. Roe FJ. Controversy: cosmetic talc and ovarian cancer. *Lancet* 1979; 2(8145): 744.
61. Whittemore AS, Wu ML, Paffenbarger RS Jr, et al. Personal and environmental characteristics related to epithelial ovarian cancer. II. Exposures to talcum powder, tobacco, alcohol, and coffee. *Am J Epidemiol* 1988; 128(6): 1228-1240.
62. Cook LS, Kamb ML, Weiss NS. Perineal powder exposure and the risk of ovarian cancer. *Am J Epidemiol* 1997; 145(5): 459-465.
63. Cramer DW, Welch WR, Scully RE, Wojciechowski CA. Ovarian cancer and talc: a case-control study. *Cancer* 1982; 50(2): 372-376.
64. West RO. Epidemiologic study of malignancies of the ovaries. *Cancer* 1966; 19(7): 1001-1007.
65. Menczer J, Modan M, Ranon L, Golan A. Possible role of mumps virus in the etiology of ovarian cancer. *Cancer* 1979; 43(4): 1375-1379.
66. Cramer DW, Welch WR, Cassells S, Scully RE. Mumps, menarche, menopause, and ovarian cancer. *Am J Obstet Gynecol* 1983; 147(1): 1-6.
67. Piver MS, Baker TR, Jishi MF, et al. Familial ovarian cancer—A report of 658 families from the Gilda Radner Familial Ovarian Cancer Registry 1981-1991. *Cancer* 1993; 71: 582-588.

68. Plotkin SA, Wharton M. Mumps Vaccine. In: *Vaccines* (Plotkin SA, Orenstein WA, eds.), 3rd ed. Saunders, Philadelphia, 1999, pp. 267–292.
69. Peltola H, Heinonen OP, Valle M, et al. The elimination of indigenous measles, mumps, and rubella from Finland by a 12-year, two-dose vaccination program. *N Engl J Med* 1994; 331(21): 1397–1402.
70. Recommendations of the Immunization Practices Advisory Committee Mumps Prevention. *MMWR* 1989; 38(22): 388–400.
71. Kerlikowske K, Brown JS, Grady DG. Should women with familial ovarian cancer undergo prophylactic oophorectomy? *Obstet Gynecol* 1992; 80(4): 700–707.
72. Schildkraut JM, Risch N, Thompson WD. Evaluating genetic association among ovarian, breast, and endometrial cancer: evidence for a breast/ovarian cancer relationship. *Am J Hum Genet* 1989; 45(4): 521–529.
73. Houlston RS, Collins A, Slack J, et al. Genetic epidemiology of ovarian cancer: segregation analysis. *Ann Hum Genet* 1991; 55(Pt 4): 291–299.
74. Bewtra C, Watson P, Conway T, Read-Hippee C, Lynch HT. Hereditary ovarian cancer: a clinicopathological study. *Int J Gynecol Pathol* 1992; 11(3): 180–187.
75. Narod SA, Madlensky L, Bradley L, et al. Hereditary and familial ovarian cancer in southern Ontario. *Cancer* 1994; 74(8): 2341–2346.
76. Lynch HT, Lynch JF, Conway TA. Hereditary ovarian cancer, in *Ovarian Cancer* (Rubin SC, Sutton GP, eds.), McGraw-Hill, New York, 1993, pp. 189–217.
77. Lynch HT, Harris RE, Guirgis HA, Maloney K, Carmody LL, Lynch JF. Familial association of breast/ovarian carcinoma. *Cancer* 1978; 41: 1543–1549.
78. Easton DF, Bishop DT, Ford D, Crockford GP. Genetic linkage analysis in familial breast and ovarian cancer: results from 214 families. The Breast Cancer Linkage Consortium. *Am J Hum Genet* 1993; 52(4): 678–701.
79. Median Age at Diagnosis and Death, 1997–2001. Surveillance, Epidemiology, and End Results, National Cancer Institute, 2004 (Accessed at [http://seer.cancer.gov/csr/1975\\_2001/sections.html](http://seer.cancer.gov/csr/1975_2001/sections.html)).
80. Robson M, Holcombe T, McCormick B, et al. Feasibility of breast conserving treatment for breast cancer in women with germline BRCA mutations: A clinic-based series. *J Clin Oncol* (Asco Ann Proc) 22(145, suppl): 9618.
81. Rubin SC, Benjamin I, Behbakht K, et al. Clinical and pathological features of ovarian cancer in women with germ-line mutations of BRCA1. *N Engl J Med* 1996; 335(19): 1413–1416.
82. Fasouliotis SJ, Schenker JG. BRCA1 and BRCA2 gene mutations: decision-making dilemmas concerning testing and management. *Obstet Gynecol Surv* 2000; 55(6): 373–384.
83. DiSaia PJ, Creasman WT. Epithelial Ovarian Cancer, in *Clinical Gynecologic Oncology* (DiSaia PJ, Creasman WT, eds.), Mosby, St. Louis, MO, 1997, pp. 282–350.
84. Hall JM, Lee MK, Newman B, et al. Linkage of early-onset familial breast cancer to chromosome 17q21. *Science* 1990; 250(4988): 1684–1689.
85. Steichen-Gersdorf E, Gallion HH, Ford D, et al. Familial site-specific ovarian cancer is linked to BRCA1 on 17q12-21. *Am J Hum Genet* 1994; 55(5): 870–875.
86. Merajver SD, Frank TS, Xu J, et al. Germline BRCA1 mutations and loss of the wild-type allele in tumors from families with early onset breast and ovarian cancer. *Clin Cancer Res* 1995; 1(5): 539–544.
87. Miki Y, Swensen J, Shattuck-Eidens D, et al. A strong candidate for the breast and ovarian cancer susceptibility gene BRCA1. *Science* 1994; 266(5182): 66–71.
88. Wooster R, Bignell G, Lancaster J, et al. Identification of the breast cancer susceptibility gene BRCA2. *Nature* 1995; 378(6559): 789–792.
89. Berchuck A, Cirisano F, Lancaster JM, et al. Role of BRCA1 mutation screening in the management of familial ovarian cancer. *Am J Obstet Gynecol* 1996; 175(3 Pt 1): 738–746.
90. Takahashi H, Behbakht K, McGovern PE, et al. Mutation analysis of the BRCA1 gene in ovarian cancers. *Cancer Res* 1995; 55(14): 2998–3002.
91. Newman B, Mu H, Butler LM, Millikan RC, Moorman PG, King MC. Frequency of breast cancer attributable to BRCA1 in a population-based series of American women. *JAMA* 1998; 279(12): 915–921.
92. Couch FJ, Hartmann LC. BRCA1 testing—advances and retreats. *JAMA* 1998; 279(12): 955–957.
93. Malone KE, Daling JR, Thompson JD, O'Brien CA, Francisco LV, Ostrander EA. BRCA1 mutations and breast cancer in the general population: analyses in women before age 35 years and in women before age 45 years with first-degree family history. *JAMA* 1998; 279(12): 922–929.

94. Moslehi R, Chu W, Karlan B, et al. BRCA1 and BRCA2 mutation analysis of 208 Ashkenazi Jewish women with ovarian cancer. *Am J Hum Genet* 2000; 66(4): 1259–1272.
95. Boyd J, Sonoda Y, Federici MG, et al. Clinicopathologic features of BRCA-linked and sporadic ovarian cancer. *JAMA* 2000; 283(17): 2260–2265.
96. Robson M, Levin D, Federici M, et al. Breast conservation therapy for invasive breast cancer in Ashkenazi women with BRCA gene founder mutations. *J Natl Cancer Inst* 1999; 91(24): 2112–2117.
97. Fodor FH, Weston A, Bleiweiss IJ, et al. Frequency and carrier risk associated with common BRCA1 and BRCA2 mutations in Ashkenazi Jewish breast cancer patients. *Am J Hum Genet* 1998; 63(1): 45–51.
98. Suzuki A, de la Pompa JL, Hakem R, et al. BRCA2 is required for embryonic cellular proliferation in the mouse. *Genes Dev* 1997; 11(10): 1242–1252.
99. Hakem R, de la Pompa JL, Mak TW. Developmental studies of BRCA1 and BRCA2 knock-out mice. *J Mammary Gland Biol Neoplasia* 1998; 3(4): 431–445.
100. Hakem R, de la Pompa JL, Sirard C, et al. The tumor suppressor gene BRCA1 is required for embryonic cellular proliferation in the mouse. *Cell* 1996; 85(7): 1009–1023.
101. Smith PD, Crossland S, Parker G, et al. Novel p53 mutants selected in BRCA-associated tumours which dissociate transformation suppression from other wild-type p53 functions. *Oncogene* 1999; 18(15): 2451–2459.
102. Crook T, Brooks LA, Crossland S, et al. p53 mutation with frequent novel condons but not a mutator phenotype in BRCA1- and BRCA2-associated breast tumours. *Oncogene* 1998; 17(13): 1681–1689.
103. Crook T, Crossland S, Crompton MR, Osin P, Gusterson BA. p53 mutations in BRCA1-associated familial breast cancer. *Lancet* 1997; 350(9078): 638–639.
104. Powell SN, Kachnic LA. Roles of BRCA1 and BRCA2 in homologous recombination, DNA replication fidelity and the cellular response to ionizing radiation. *Oncogene* 2003; 22(37): 5784–5791.
105. Kinzler KW, Vogelstein B. Cancer-susceptibility genes. Gatekeepers and caretakers. *Nature* 1997; 386(6627): 761–763.
106. Patel KJ, Yu VP, Lee H, et al. Involvement of Brca2 in DNA repair. *Mol Cell* 1998; 1(3): 347–357.
107. Tirkkonen M, Johannsson O, Agnarsson BA, et al. Distinct somatic genetic changes associated with tumor progression in carriers of BRCA1 and BRCA2 germ-line mutations. *Cancer Res* 1997; 57(7): 1222–1227.
108. Gretarsdottir S, Thorlacius S, Valgardsdottir R, et al. BRCA2 and p53 mutations in primary breast cancer in relation to genetic instability. *Cancer Res* 1998; 58(5): 859–862.
109. Xu X, Wagner KU, Larson D, et al. Conditional mutation of Brca1 in mammary epithelial cells results in blunted ductal morphogenesis and tumour formation. *Nat Genet* 1999; 22(1): 37–43.
110. Goodman MF. Coping with replication “train wrecks” in *Escherichia coli* using Pol V, Pol II and RecA proteins. *Trends Biochem Sci* 2000; 25(4): 189–195.
111. Chen J, Silver DP, Walpita D, et al. Stable interaction between the products of the BRCA1 and BRCA2 tumor suppressor genes in mitotic and meiotic cells. *Mol Cell* 1998; 2(3): 317–328.
112. Chen PL, Chen CF, Chen Y, Xiao J, Sharp ZD, Lee WH. The BRC repeats in BRCA2 are critical for RAD51 binding and resistance to methyl methanesulfonate treatment. *Proc Natl Acad Sci USA* 1998; 95(9): 5287–5292.
113. Davies AA, Masson JY, McIlwraith MJ, et al. Role of BRCA2 in control of the RAD51 recombination and DNA repair protein. *Mol Cell* 2001; 7(2): 273–282.
114. Snouwaert JN, Gowen LC, Latour AM, et al. BRCA1 deficient embryonic stem cells display a decreased homologous recombination frequency and an increased frequency of non-homologous recombination that is corrected by expression of a brca1 transgene. *Oncogene* 1999; 18(55): 7900–7907.
115. Moynahan ME, Cui TY, Jasin M. Homology-directed dna repair, mitomycin-c resistance, and chromosome stability is restored with correction of a Brca1 mutation. *Cancer Res* 2001; 61(12): 4842–4850.
116. Xu B, Kim S, Kastan MB. Involvement of Brca1 in S-phase and G(2)-phase checkpoints after ionizing irradiation. *Mol Cell Biol* 2001; 21(10): 3445–3450.
117. Kraakman-van der Zwet M, Overkamp WJ, van Lange RE, et al. Brca2 (XRCC11) deficiency results in radioresistant DNA synthesis and a higher frequency of spontaneous deletions. *Mol Cell Biol* 2002; 22(2): 669–679.
118. Xu X, Weaver Z, Linke SP, et al. Centrosome amplification and a defective G2-M cell cycle checkpoint induce genetic instability in BRCA1 exon 11 isoform-deficient cells. *Mol Cell* 1999; 3(5): 389–395.



119. Chen CF, Chen PL, Zhong Q, Sharp ZD, Lee WH. Expression of BRC repeats in breast cancer cells disrupts the BRCA2-Rad51 complex and leads to radiation hypersensitivity and loss of G(2)/M checkpoint control. *J Biol Chem* 1999; 274(46): 32,931–32,935.
120. Xu B, O'Donnell AH, Kim ST, Kastan MB. Phosphorylation of serine 1387 in BRCA1 is specifically required for the Atm-mediated S-phase checkpoint after ionizing irradiation. *Cancer Res* 2002; 62(16): 4588–4591.
121. Ford D, Easton DF, Stratton M, et al. Genetic heterogeneity and penetrance analysis of the BRCA1 and BRCA2 genes in breast cancer families. The Breast Cancer Linkage Consortium. *Am J Hum Genet* 1998; 62(3): 676–689.
122. Brose MS, Rebbeck TR, Calzone KA, Stopfer JE, Nathanson KL, Weber BL. Cancer risk estimates for BRCA1 mutation carriers identified in a risk evaluation program. *J Natl Cancer Inst* 2002; 94(18): 1365–1372.
123. Struewing JP, Hartge P, Wacholder S, et al. The risk of cancer associated with specific mutations of BRCA1 and BRCA2 among Ashkenazi Jews. *N Engl J Med* 1997; 336(20): 1401–1408.
124. Satagopan JM, Offit K, Foulkes W, et al. The lifetime risks of breast cancer in Ashkenazi Jewish carriers of BRCA1 and BRCA2 mutations. *Cancer Epidemiol Biomarkers Prev* 2001; 10(5): 467–473.
125. Risch HA, McLaughlin JR, Cole DE, et al. Prevalence and penetrance of germline BRCA1 and BRCA2 mutations in a population series of 649 women with ovarian cancer. *Am J Hum Genet* 2001; 68(3): 700–710.
126. Satagopan JM, Boyd J, Kauff ND, et al. Ovarian cancer risk in Ashkenazi Jewish carriers of BRCA1 and BRCA2 mutations. *Clin Cancer Res* 2002; 8(12): 3776–3781.
127. Moller P, Borg A, Evans DG, et al. Survival in prospectively ascertained familial breast cancer: analysis of a series stratified by tumour characteristics, BRCA mutations and oophorectomy. *Int J Cancer* 2002; 101(6): 555–559.
128. Burke W, Petersen G, Lynch P, et al. Recommendations for follow-up care of individuals with an inherited predisposition to cancer. I. Hereditary nonpolyposis colon cancer. Cancer Genetics Studies Consortium. *JAMA* 1997; 277(11): 915–919.
129. Aarnio M, Mecklin JP, Aaltonen LA, Nystrom-Lahti M, Jarvinen HJ. Life-time risk of different cancers in hereditary non-polyposis colorectal cancer (HNPCC) syndrome. *Int J Cancer* 1995; 64(6): 430–433.
130. Aarnio M, Sankila R, Pukkala E, et al. Cancer risk in mutation carriers of DNA-mismatch-repair genes. *Int J Cancer* 1999; 81(2): 214–218.
131. Dunlop MG, Farrington SM, Carothers AD, et al. Cancer risk associated with germline DNA mismatch repair gene mutations. *Hum Mol Genet* 1997; 6(1): 105–110.
132. Vasen HF, Wijnen JT, Menko FH, et al. Cancer risk in families with hereditary nonpolyposis colorectal cancer diagnosed by mutation analysis. *Gastroenterology* 1996; 110(4): 1020–1027.
133. Watson P, Lynch HT. Extracolonic cancer in hereditary nonpolyposis colorectal cancer. *Cancer* 1993; 71(3): 677–685.
134. Aaltonen LA, Peltomaki P, Leach FS, et al. Clues to the pathogenesis of familial colorectal cancer. *Science* 1993; 260(5109): 812–816.
135. Leach FS, Nicolaides NC, Papadopoulos N, et al. Mutations of a mutS homolog in hereditary non-polyposis colorectal cancer. *Cell* 1993; 75(6): 1215–1225.
136. Risinger JI, Berchuck A, Kohler MF, Watson P, Lynch HT, Boyd J. Genetic instability of microsatellites in endometrial carcinoma. *Cancer Res* 1993; 53(21): 5100–5103.
137. Bellacosa A, Genuardi M, Anti M, Viel A, Ponz de Leon M. Hereditary nonpolyposis colorectal cancer: review of clinical, molecular genetics, and counseling aspects. *Am J Med Genet* 1996; 62(4): 353–364.
138. Samowitz WS, Curtin K, Lin HH, et al. The colon cancer burden of genetically defined hereditary nonpolyposis colon cancer. *Gastroenterology* 2001; 121(4): 830–838.
139. Percepe A, Borghi F, Menigatti M, et al. Molecular screening for hereditary nonpolyposis colorectal cancer: a prospective, population-based study. *J Clin Oncol* 2001; 19(19): 3944–3950.
140. Salovaara R, Loukola A, Kristo P, et al. Population-based molecular detection of hereditary nonpolyposis colorectal cancer. *J Clin Oncol* 2000; 18(11): 2193–2200.
141. Tinley ST, Lynch HT. Integration of family history and medical management of patients with hereditary cancers. *Cancer* 1999; 86(Suppl 11): 2525–2532.
142. Statement of the American Society of Clinical Oncology: genetic testing for cancer susceptibility, Adopted on February 20, 1996. *J Clin Oncol* 1996; 14(5): 1730–1736, discussion 1737–1740.

143. Frank TS, Manley SA, Olopade OI, et al. Sequence analysis of BRCA1 and BRCA2: correlation of mutations with family history and ovarian cancer risk. *J Clin Oncol* 1998; 16(7): 2417–2425.
144. Couch FJ, DeShano ML, Blackwood MA, et al. BRCA1 mutations in women attending clinics that evaluate the risk of breast cancer. *N Engl J Med* 1997; 336(20): 1409–1415.
145. Burke W, Daly M, Garber J, et al. Recommendations for follow-up care of individuals with an inherited predisposition to cancer. II. BRCA1 and BRCA2. Cancer Genetics Studies Consortium. *JAMA* 1997; 277(12): 997–1003.
146. Mackey SE, Creasman WT. Ovarian cancer screening. *J Clin Oncol* 1995; 13(3): 783–793.
147. NIH consensus conference. Ovarian cancer. Screening, treatment, and follow-up. NIH Consensus Development Panel on Ovarian Cancer. *JAMA* 1995; 273(6): 491–497.
148. Skates SJ, Pauler DK, Jacobs IJ. Screening based on the risk of cancer calculation from bayesian hierarchical changepoint and mixture models of longitudinal markers. *J Am Stat Assoc* 2001; 96: 429.
149. van Nagell JR Jr, DePriest PD, Reedy MB, et al. The efficacy of transvaginal sonographic screening in asymptomatic women at risk for ovarian cancer. *Gynecol Oncol* 2000; 77(3): 350–356.
150. Jacobs IJ, Skates S, Davies AP, et al. Risk of diagnosis of ovarian cancer after raised serum CA 125 concentration: a prospective cohort study. *BMJ* 1996; 313(7069): 1355–1358.
151. van Nagell JR Jr, Gallion HH, Pavlik EJ, DePriest PD. Ovarian cancer screening. *Cancer* 1995; 76(Suppl 10): 2086–2091.
152. Botkin JR, Smith KR, Croyle RT, et al. Genetic testing for a BRCA1 mutation: Prophylactic surgery and screening behavior in women 2 years post testing. *Am J Med Genet* 2003; 118A(3): 201–209.
153. Petricoin EF, Ardekani AM, Hitt BA, et al. Use of proteomic patterns in serum to identify ovarian cancer. *Lancet* 2002; 359(9306): 572–577.
154. Modan B, Hartge P, Hirsh-Yechezkel G, et al. Parity, oral contraceptives, and the risk of ovarian cancer among carriers and noncarriers of a BRCA1 or BRCA2 mutation. *N Engl J Med* 2001; 345(4): 235–240.
155. Rosenberg L, Palmer JR, Zauber AG, et al. A case-control study of oral contraceptive use and invasive epithelial ovarian cancer. *Am J Epidemiol* 1994; 139(7): 654–661.
156. Schildkraut JM, Calingaert B, Marchbanks PA, Moorman PG, Rodriguez GC. Impact of progestin and estrogen potency in oral contraceptives on ovarian cancer risk. *J Natl Cancer Inst* 2002; 94(1): 32–38.
157. Rodriguez GC, Nagarsheth NP, Lee KL, et al. Progestin-induced apoptosis in the Macaque ovarian epithelium: differential regulation of transforming growth factor-beta. *J Natl Cancer Inst* 2002; 94(1): 50–60.
158. Rodriguez GC, Walmer DK, Cline M, et al. Effect of progestin on the ovarian epithelium of macaques: cancer prevention through apoptosis? *J Soc Gynecol Invest* 1998; 5: 271–276.
159. Brewer MA, Mitchell MF, Bast RC. Prevention of ovarian cancer. *In Vivo* 1999; 13(1): 99–106.
160. Zhang D, Holmes WF, Wu S, Soprano DR, Soprano KJ. Retinoids and ovarian cancer. *J Cell Physiol* 2000; 185(1): 1–20.
161. Formelli F, Cleris L. Synthetic retinoid fenretinide is effective against a human ovarian carcinoma xenograft and potentiates cisplatin activity. *Cancer Res* 1993; 53(22): 5374–5376.
162. Supino R, Crosti M, Clerici M, et al. Induction of apoptosis by fenretinide (4HPR) in human ovarian carcinoma cells and its association with retinoic acid receptor expression. *Int J Cancer* 1996; 65(4): 491–497.
163. Sabichi AL, Hendricks DT, Bober MA, Birrer MJ. Retinoic acid receptor beta expression and growth inhibition of gynecologic cancer cells by the synthetic retinoid N-(4-hydroxyphenyl) retinamide. *J Natl Cancer Inst* 1998; 90(8): 597–605.
164. De Palo G, Camerini T, Marubini E, et al. Chemoprevention trial of contralateral breast cancer with fenretinide. Rationale, design, methodology, organization, data management, statistics and accrual. *Tumori* 1997; 83(6): 884–894.
165. Devesa SS, Grauman DJ, Blot WJ, Pennello G, Hoover RN, Fraumeni JF Jr. Atlas of Cancer Mortality in the US: 1950–1994. NIH Publication No. 99-4564, Washington, DC, US Govt Print Off, 1999.
166. Ferlay Bray F, Pisani P, Parkin DM. GLOBOCAN 2000: Cancer incidence, mortality and prevalence worldwide, Version 1.0 ed. Lyon: IARC Press; 2001.
167. Lefkowitz ES, Garland CF. Sunlight, vitamin D, and ovarian cancer mortality rates in US women. *Int J Epidemiol* 1994; 23(6): 1133–1136.
168. Schwartz GG, Hulka BS. Is vitamin D deficiency a risk factor for prostate cancer? (Hypothesis). *Anticancer Res* 1990; 10(5A): 1307–1311.

169. Corder EH, Guess HA, Hulka BS, et al. Vitamin D and prostate cancer: a prediagnostic study with stored sera. *Cancer Epidemiol Biomarkers Prev* 1993; 2(5): 467–472.
170. Schwartz GG, Oeler TA, Uskokovic MR, Bahnson RR. Human prostate cancer cells: inhibition of proliferation by vitamin D analogs. *Anticancer Res* 1994; 14(3A): 1077–1081.
171. Design of the Women's Health Initiative clinical trial and observational study. The Women's Health Initiative Study Group. *Control Clin Trials* 1998; 19(1): 61–109.
172. Cramer DW, Harlow BL, Titus-Ernstoff L, Bohlke K, Welch WR, Greenberg ER. Over-the-counter analgesics and risk of ovarian cancer. *Lancet* 1998; 351(9096): 104–107.
173. Moysich KB, Mettlin C, Piver MS, Natarajan N, Menezes RJ, Swede H. Regular use of analgesic drugs and ovarian cancer risk. *Cancer Epidemiol Biomarkers Prev* 2001; 10(8): 903–906.
174. Rosenberg L, Palmer JR, Rao RS, et al. A case-control study of analgesic use and ovarian cancer. *Cancer Epidemiol Biomarkers Prev* 2000; 9(9): 933–937.
175. Tavani A, Gallus S, La Vecchia C, Conti E, Montella M, Franceschi S. Aspirin and ovarian cancer: an Italian case-control study. *Ann Oncol* 2000; 11(9): 1171–1173.
176. Akhmedkhanov A, Toniolo P, Zeleniuch-Jacquotte A, Kato I, Koenig KL, Shore RE. Aspirin and epithelial ovarian cancer. *Prev Med* 2001; 33(6): 682–687.
177. Rodriguez-Burford C, Barnes MN, Oelschlagel DK, et al. Effects of nonsteroidal anti-inflammatory agents (NSAIDs) on ovarian carcinoma cell lines: preclinical evaluation of NSAIDs as chemopreventive agents. *Clin Cancer Res* 2002; 8(1): 202–209.
178. Xu XC. COX-2 inhibitors in cancer treatment and prevention, a recent development. *Anticancer Drugs* 2002; 13(2): 127–137.
179. Dannenberg AJ, Altorki NK, Boyle JO, et al. Cyclo-oxygenase 2: a pharmacological target for the prevention of cancer. *Lancet Oncol* 2001; 2(9): 544–551.
180. Smith ER, Daly MB, Xu XX. A mechanism for cox-2 inhibitor anti-inflammatory activity in chemoprevention of epithelial cancers. *Cancer Epidemiol Biomarkers Prev* 2004; 13(1): 144–145.
181. Rebbeck TR, Lynch HT, Neuhausen SL, et al. Prophylactic oophorectomy in carriers of BRCA1 or BRCA2 mutations. *N Engl J Med* 2002; 346(21): 1616–1622.
182. Kauff ND, Satagopan JM, Robson ME, et al. Risk-reducing salpingo-oophorectomy in women with a BRCA1 or BRCA2 mutation. *N Engl J Med* 2002; 346(21): 1609–1615.
183. Tobacman JK, Greene MH, Tucker MA, Costa J, Kase R, Fraumeni JF, Jr. Intra-abdominal carcinomatosis after prophylactic oophorectomy in ovarian-cancer-prone families. *Lancet* 1982; 2(8302): 795–797.
184. Scheuer L, Kauff N, Robson M, et al. Outcome of preventive surgery and screening for breast and ovarian cancer in BRCA mutation carriers. *J Clin Oncol* 2002; 20(5): 1260–1268.
185. Colgan TJ, Murphy J, Cole DE, Narod S, Rosen B. Occult carcinoma in prophylactic oophorectomy specimens: prevalence and association with BRCA germline mutation status. *Am J Surg Pathol* 2001; 25(10): 1283–1289.
186. Lu KH, Garber JE, Cramer DW, et al. Occult ovarian tumors in women with BRCA1 or BRCA2 mutations undergoing prophylactic oophorectomy. *J Clin Oncol* 2000; 18(14): 2728–2732.
187. Fisher B, Costantino JP, Redmond CK, Fisher ER, Wickerham DL, Cronin WM. Endometrial cancer in tamoxifen-treated breast cancer patients: findings from the National Surgical Adjuvant Breast and Bowel Project (NSABP) B-14. *J Natl Cancer Inst* 1994; 86(7): 527–537.
188. Fisher B, Costantino JP, Wickerham DL, et al. Tamoxifen for prevention of breast cancer: report of the National Surgical Adjuvant Breast and Bowel Project P-1 Study. *J Natl Cancer Inst* 1998; 90(18): 1371–1388.
189. Meijers-Heijboer H, Brekelmans CT, Menke-Pluymers M, et al. Use of genetic testing and prophylactic mastectomy and oophorectomy in women with breast or ovarian cancer from families with a BRCA1 or BRCA2 mutation. *J Clin Oncol* 2003; 21(9): 1675–1681.
190. Tiller K, Meiser B, Butow P, et al. Psychological impact of prophylactic oophorectomy in women at increased risk of developing ovarian cancer: a prospective study. *Gynecol Oncol* 2002; 86(2): 212–219.
191. Boyd J. Molecular genetics of hereditary ovarian cancer. *Oncology* (Huntingt) 1998; 12(3): 399–406; discussion 409–310.
192. Lynch HT, Schuelke GS, Kimberling WJ, et al. Hereditary nonpolyposis colorectal cancer (Lynch syndromes I and II). II. Biomarker studies. *Cancer* 1985; 56(4): 939–951.
193. Lynch HT, Kimberling W, Albano WA, et al. Hereditary nonpolyposis colorectal cancer (Lynch syndromes I and II). I. Clinical description of resource. *Cancer* 1985; 56(4): 934–938.

194. Boyd J. Molecular genetics of hereditary ovarian cancer, in *Ovarian Cancer* (Rubin SC, Sutton GP, eds.), 2nd ed., Williams & Wilkins, Lippincott, Philadelphia, 2001, pp. 3–22.
195. Shattuck-Eidens D, Oliphant A, McClure M, et al. BRCA1 sequence analysis in women at high risk for susceptibility mutations. Risk factor analysis and implications for genetic testing. *JAMA* 1997; 278(15): 1242–1250.
196. Levine DA, Gemignani ML. Prophylactic surgery in hereditary breast/ovarian cancer syndrome. *Oncology* (Huntingt) 2003; 17(7): 932–941; discussion 946–948, 950–952.
197. Easton DF, Ford D, Bishop DT. Breast and ovarian cancer incidence in BRCA1-mutation carriers. Breast Cancer Linkage Consortium. *Am J Hum Genet* 1995; 56(1): 265–271.

# 12

---

## Hereditary Factors in Endometrial Cancer

---

*Henry T. Lynch, MD, Murray Joseph Casey, MD,  
Joseph A. Knezetic, PhD, Trudy G. Shaw, MA,  
Jane F. Lynch, BSN, and Chhanda Bewtra, MD*

### CONTENTS

INTRODUCTION  
FAMILIAL AND HEREDITARY TERMINOLOGY  
DISTINCTION BETWEEN EC AND UTERINE CERVICAL CARCINOMA  
TAKING THE FAMILY HISTORY  
PATHOLOGY OF ENDOMETRIAL CARCINOMA  
MOLECULAR PATHOLOGY OF EC  
MICROSATELLITE INSTABILITY  
LYNCH SYNDROME MUTATIONS AND EC  
ORGAN SITE CANCER SELECTION  
HORMONES AND EC  
CLINICAL CHARACTERISTICS OF EC IN LYNCH SYNDROME  
AGE OF EC DIAGNOSIS IN LYNCH SYNDROME  
OVARIAN CANCER AND EC  
MULTIPLE PRIMARY CANCERS  
SURVEILLANCE AND SURGICAL PROPHYLAXIS  
DISCUSSION  
CONCLUSION  
REFERENCES

---

### 1. INTRODUCTION

Over 40,000 cases of endometrial cancer (EC) accounting for more than 7000 deaths occur in the United States each year (1). About 10–15% of these cases are found in family clusters, of which approx 7% will have a clear-cut hereditary etiology. The majority of hereditary EC cases are found in families with the Lynch syndrome, also called hereditary nonpolyposis colorectal cancer (HNPCC) syndrome (2,3). Other extracolonic cancers of the Lynch syndrome include carcinomas of the ovary, stomach,

From: *Current Clinical Oncology: Molecular Pathology of Gynecologic Cancer*  
Edited by: A. Giordano, A. Bovicelli, and R. Kurman © Humana Press Inc., Totowa, NJ

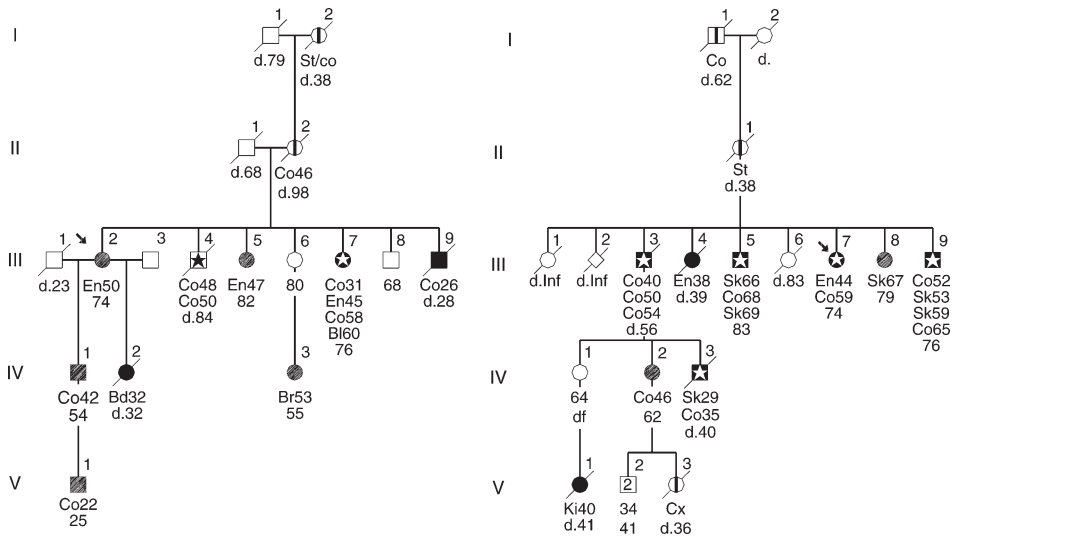

**Fig. 1.** Pedigrees of two Lynch syndrome families showing EC in the direct genetic lineage. (Republished by permission from ref. 75.)

small bowel, hepatobiliary tract, pancreas, breast, brain, and transitional cell carcinoma of the ureter and renal pelvis (4). Figure 1 shows two pedigrees that depict typical Lynch syndrome families with EC in the direct genetic lineage. The purpose of this chapter is to describe hereditary EC, its phenotypical features, molecular genetics, pathology, diagnosis, and management strategies.

## 2. FAMILIAL AND HEREDITARY TERMINOLOGY

Families containing two or more first- and/or second-degree relatives with EC are designated as showing “familial” cancer clustering. The term familial does not consider age of onset or extrauterine cancers, such as colorectal or ovarian cancer, which if found in combination with EC, are cardinal features of the Lynch syndrome (4). Subsets of familial EC, when pedigrees are more extensively studied, may, in fact, be found to be hereditary.

Hereditary EC, in contrast, is a more precise term that specifies a segregating model of EC transmission within a family pedigree, which is consistent with Mendelian autosomal dominant inheritance. Hereditary EC most commonly occurs in the Lynch syndrome, the cardinal features of which are shown in Table 1. Genetic susceptibility to EC in a specific family might be confirmed by identification of a cancer-associated germline mutation in a mismatch repair (MMR) gene, such as *MSH2*, *MLH1*, or *MSH6* (2,3).

Hereditary site-specific occurrences of EC have been described (5). However, when diagnosing this so-called “genetic entity,” one must constantly search for features of known hereditary syndromes. For example, Fig. 2 is the pedigree of a family in which EC has occurred in three generations (II-3, III-7, and III-10, as IV-5). But notice the later age of onset in the progenitor (II-3) and her sister (II-4), and also ovarian cancer in two individuals (III-4 and IV-8) and breast carcinoma in the proband (III-10).

**Table 1**  
**Cardinal Features of Lynch Syndrome**

- 
- Earlier average age of CRC onset than in the general population; the average age of CRC onset in HNPCC is approx 45 years, whereas the average age of onset in sporadic CRC is approx 63 years
  - Proximal colon involvement (70% of CRCs arise proximal to the splenic flexure)
  - A significant excess of synchronous and metachronous CRCs (approx 25–30% among patients having a second primary CRC within 10 years of surgical resection for initial CRC, if the surgery was anything less than a subtotal colectomy)
  - Autosomal dominant inheritance pattern
  - Increased risk for malignancy at certain extracolonic sites, foremost of which is endometrial carcinoma, followed by carcinoma of the ovary, stomach, small bowel, hepatobiliary tract, pancreas, upper uro-epithelial tract, and brain
  - CRC tumors in HNPCC are more often poorly differentiated, with an excess of mucoid and signet-cell features, show a Crohn's-like reaction, and contain a significant excess of infiltrating lymphocytes within the tumor. MSI is found in most CRC tumors in the Lynch syndrome
  - Increased survival from CRC
  - Accelerated carcinogenesis and interval CRC; a tiny adenoma may emerge into a carcinoma within 2–3 years, as opposed to 8–10 years in the general population
  - Sebaceous adenomas, sebaceous carcinomas, and multiple keratoacanthomas in the Muir–Torre syndrome variant of Lynch syndrome
  - The *sine qua non*, the identification of a germline *MMR* mutation segregating with syndrome-affected individuals in the family
- 

This raises questions as to whether Lynch syndrome or another hereditary cancer disorder, such as the hereditary breast-ovarian cancer syndrome (6,7) can be dealt with.

EC may occur with other genital cancers, such as ovarian or tubal carcinomas, perhaps as a part of a Mullerian field effect. But with the exception of colorectal carcinomas (8) in the Lynch syndrome, the occurrence with any nongenital malignancy is distinctly uncommon. The lifetime risk of EC in carriers of a Lynch syndrome germline mutation is 40–60% (8,9), whereas Lynch syndrome-related hereditary ECs constitute an estimated 7% of the total number of endometrial malignancies (2,3). Other rare instances of hereditary ECs include Cowden's syndrome, linked to *PTEN* mutations in chromosome 10, and characterized by autosomal dominant inheritance, multiple hamartomatous lesions, and carcinomas of endometrium, breast, and ovaries (10–12). There has also been an anecdotal report of lymphomas with endometrial and ovarian cancers observed in two relatives in the direct genetic lineage (5).

### 3. DISTINCTION BETWEEN EC AND UTERINE CERVICAL CARCINOMA

One of the most vexing problems in the interpretation of the genetics of EC relates to the loose handling of the definition of this disorder. For example, Way (13) in 1954, commented on the confusion in reporting uterine fundus, and uterine cervix carcinomas as being because of the "...pernicious habit that doctors in general have of talking very loosely about uterine cancer." He stressed even more strongly the fallacy of reporting data based on death certificate verification as follows: "I would plead for a much more careful differentiation of cervical and corporeal cancer in all levels of medicine and at the same time I

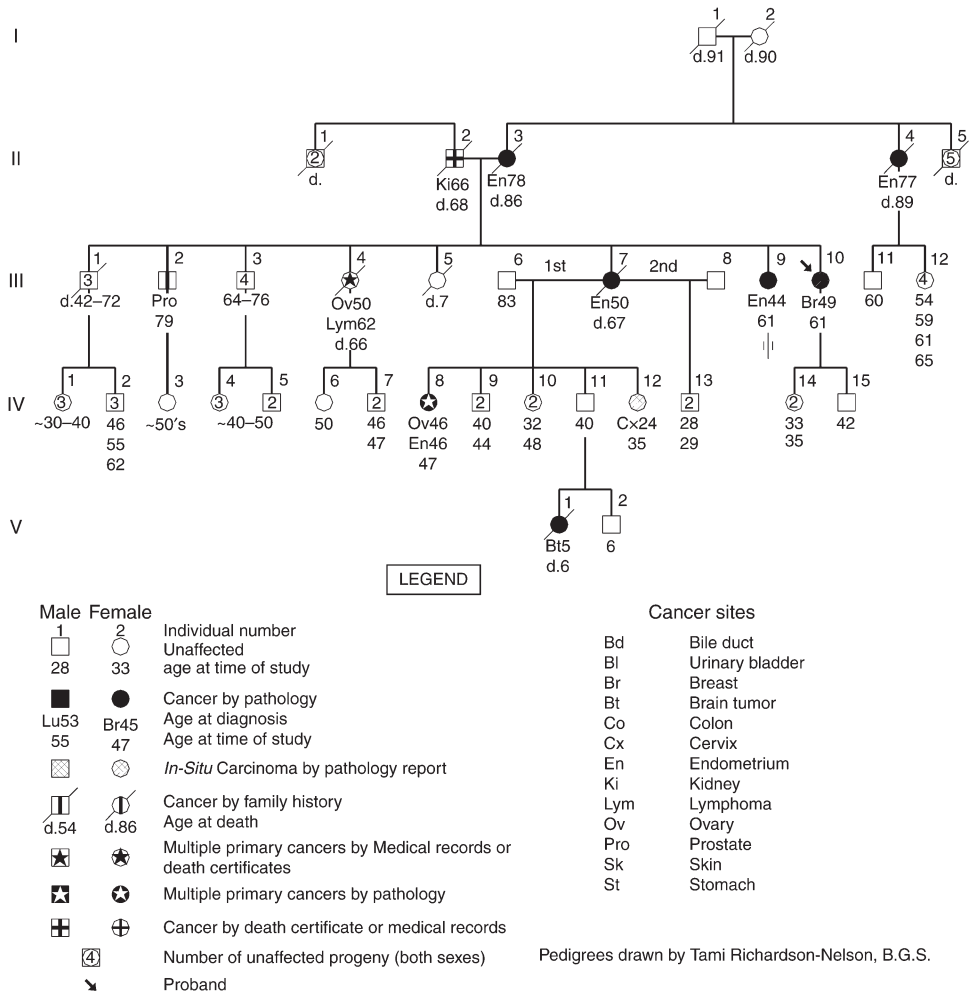
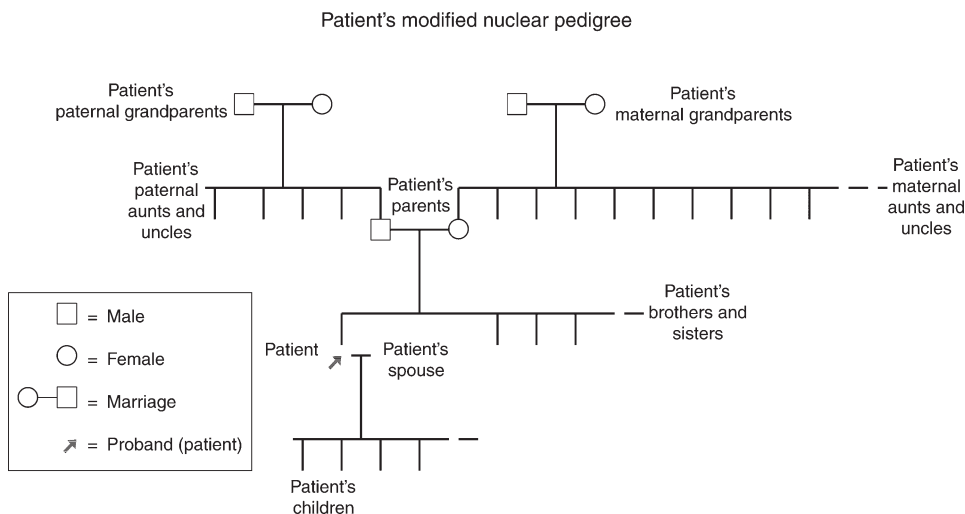

**Fig. 2.** Pedigree of family showing endometrial carcinoma in five women through three generations (Republished by permission from ref. 5).

would warn you that the growing number of papers based on the statistical analysis of the cause of death as certified on death certificates are not worth the paper they are written on. Nothing can take the place of careful, extensive documentation. Only after you have done that, can you get out the slide rule and the log tables so beloved by the mathematician, but you cannot get out of statistics more than you put in.” Although, Dr. Way made these statements 50 years back, the problems about which he spoke still exist, despite the fact that slide rules and log tables have given way to calculators and computers.

Murphy (14) studied 201 probands with EC and had similar problems because of the lack of differentiation between EC and cervical carcinoma. He found an increased risk for uterine cancer in relatives of affected probands, but it was impossible to assess whether this risk was for cervical carcinoma or EC. Having pooled the data for EC and cervical carcinoma, he states, “...We have combined the figures for cancer of the cervix and fundus because examination of the data convinced us that separation is impossible.





**Fig. 3.** Patient's modified nuclear pedigree.

A high proportion of reported uterine cancer in our data is, we believe, really cervical cancer.” Studying these lesions in combination is entirely inappropriate, as they have different cell types, histologies, and expectantly, different etiologies.

#### 4. TAKING THE FAMILY HISTORY

In most instances of hereditary EC, the family history, when extended through three generations in the modified nuclear pedigree (Fig. 3), will demonstrate patterns of cancer clustering, which merit the consideration of a hereditary cancer syndrome. Details about the proband's cancer history and the histories of parents, siblings, progeny, and both paternal and maternal lineages, including cancer of all anatomical sites with pathology documentation whenever possible, will serve to confirm the initial impression. Extended pedigree analysis is essential and must include parents, grandparents, aunts, and uncles who are likely to be older individuals who, having passed through the cancer risk age will be genetically more informative.

Ivanovich et al. (15) analyzed the process for collecting and verifying reported cancer family histories and concurrently evaluating inaccuracies from a series of women with EC. They obtained detailed family histories from 80 women. Medical records were obtained to verify cancer reporting. Findings showed that medical records were more likely to be obtained when the cancer-affected relative was living and closely related to the study participant in whom the cancer type was already known. Expectedly, the success in retrieving medical records decreased with increasing age of the records ( $p < 0.001$ ). Inaccurate reporting was identified in 28.6% of verified cancers. In addition, there was a significantly higher number of inaccurate reports among second-degree and third-degree relatives as opposed to first-degree relatives ( $p = 0.02$ ). The authors concluded that additional studies to improve record collection efficiency and to identify cancer reporting accuracy are needed among the general research community.

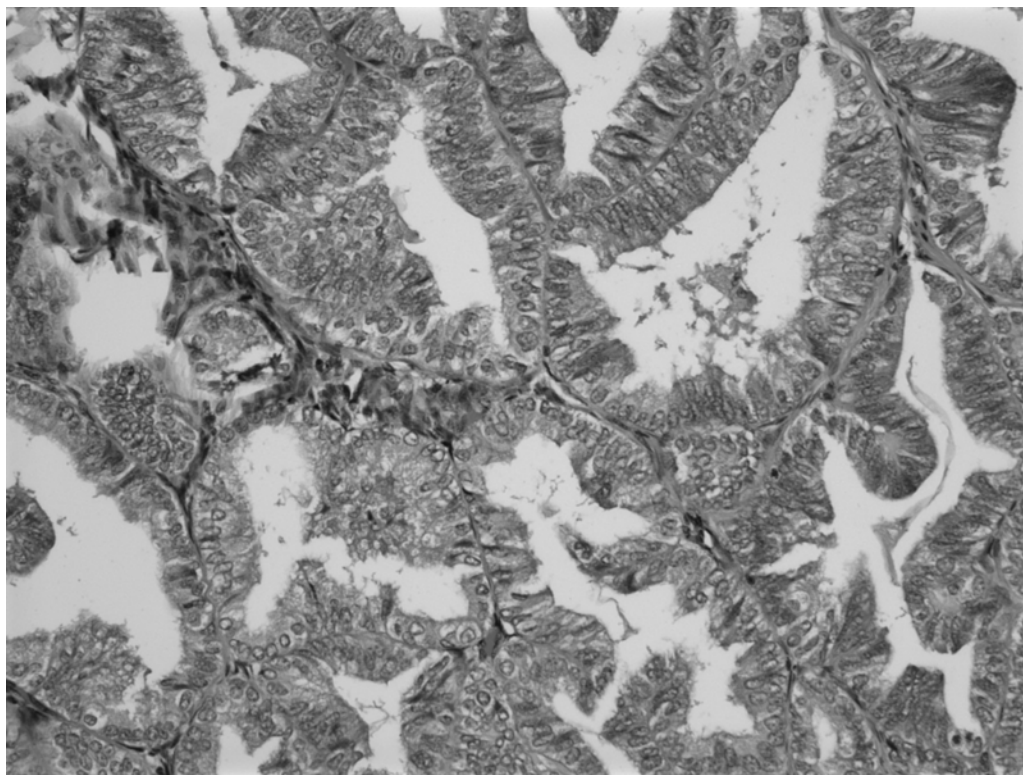
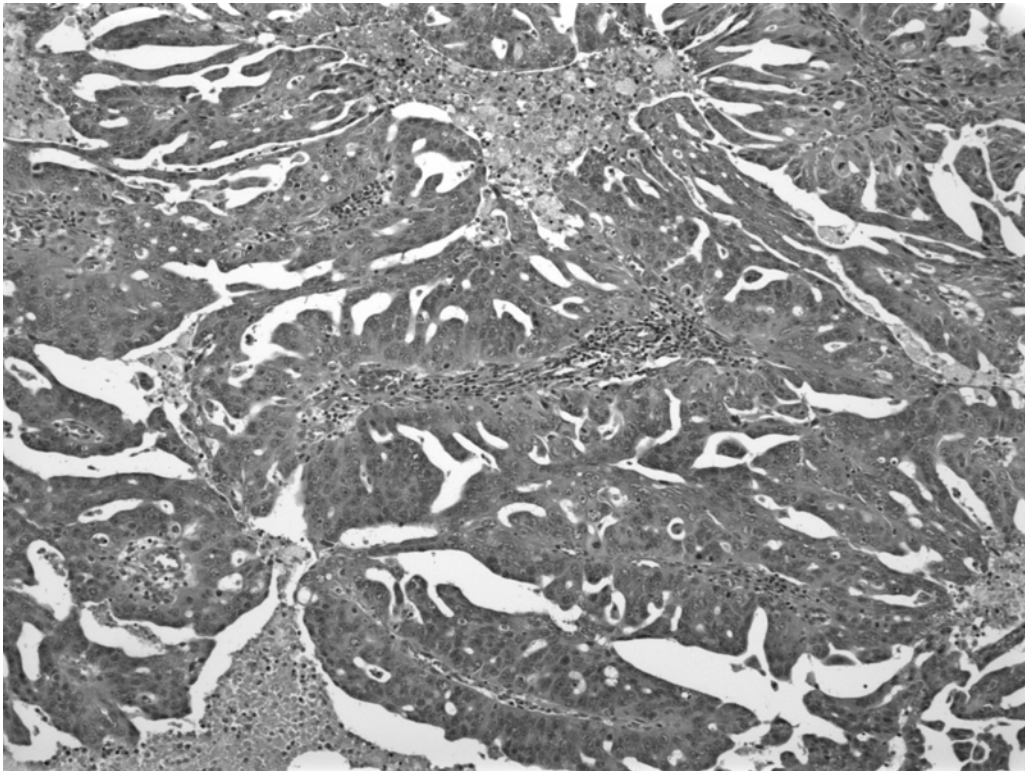

**Fig. 4.** Prototype endometrioid carcinoma.

## 5. PATHOLOGY OF ENDOMETRIAL CARCINOMA

Nyholm et al. (16) suggested in 1993 that EC is a complex disorder with two distinct variants, which have since been designated as type I and type II. Type I is characterized by endometrioid histology and occurs in women with certain classical features associated with hyperestrogenism, including obesity, anovulation, nulliparity, exogenous estrogen, and endometrial hyperplasia. Type II is of serous cell type, which appears to lack direct hormonal influence and may arise as anaplastic cancer in older women even in the presence of atrophic endometrium.

The most common EC variant is the endometrioid type, with an indolent biological behavior. The aggressive serous, papillary, and clear cell types of EC fortunately are rarer. Other types of ECs include pure squamous, mixed adenosquamous, mucinous, and mixed types. It is the endometrioid type carcinoma that is often preceded by endometrial precursor lesions, such as complex and atypical endometrial hyperplasia. Type I cancers (prototype endometrioid carcinomas) (Fig. 4) are often well differentiated, typically slow-growing cancers with usually excellent prognosis. Type I ECs (approx 80% of all ECs) tend to occur in perimenopausal or recently postmenopausal women with preceding endometrial hyperplasia and other indications of excessive estrogenic effects unopposed by progesterone. Endometrioid tumors may show glandular, solid, or villoglandular histological patterns. Occasional morules of benign squamous metaplasias can be seen. Predictably, these tumors have high estrogen receptor (ER) and progesterone receptor (PR) content and respond well to treatment. However, there is marked heterogeneity in the expressions of these receptors



**Fig. 5.** Prototype serous papillary carcinoma.

as demonstrated by tissue immunohistochemistry, which makes interpretation difficult in routine clinical situations. Because there is excellent correlation of tissue hormone receptors with histological type and grade of the tumor, ER and PR are not routinely measured in type I ECs (17,18). To date, there has been no reported systematic comparison of the hormone receptors in sporadic and hereditary endometrial carcinomas.

Type II cancers (prototype serous papillary carcinomas) (Fig. 5) on the other hand, tend to occur in older, late postmenopausal women with no previous sign of excess estrogen effect. These tumors (approx 10% of all ECs) are high grade, biologically aggressive, hormone receptor negative, and have a poor prognosis. They are characterized by distinct papillae with fibrovascular cores and markedly atypical nuclei. Clear cell and “hobnail” features are not uncommon. The histology closely resembles serous papillary tumors of the ovary. The precursor lesion of this tumor is flat, and superficial glandular change is characterized by marked nuclear atypia. This is termed endometrial intraepithelial neoplasia (EIN) and is usually seen in an atrophic background. The predominant molecular marker for this tumor is mutation of *p53*, a tumor inhibitor gene. Immunoperoxidase stains with DO7 (anti-*p53*) marks 70–100% of serous papillary ECs as well as the precursor EIN lesions (19,20). Other useful molecular markers include high cell proliferation markers, such as MIB-1 and Ki-67, and loss of heterozygosity (LOH) in multiple chromosomal regions. In contrast to the serous papillary tumors of the ovary, these ECs are negative for WT-1 (21,22).

Both endometrioid and serous EC can manifest a primary genetic etiology, although most studies show that hereditary EC more commonly is of endometrioid histology and

hereditary serous EC is rare. Hereditary endometrioid EC shares pathological features with type I EC. However, because the role of estrogen in hereditary EC is still elusive, if type I is defined as involving hyperestrogenism, it is unclear whether hereditary ECs would fall into that category. Sporadic and hereditary endometrioid ECs follow separate molecular genetic pathways during carcinogenesis (*infra vide*). Recently (22a), *MLH1* promoter hypermethylation has been found in 91% of ECs with micro-satellite instabilities causing loss of *MLH1* expression. Moreover, primary hereditary factors may predispose susceptible individuals to the perturbation of endogenous or exogenous cofactors.

Endometrioid carcinoma is the most frequently diagnosed EC in HNPCC syndrome patients, and no survival or prognostic differences are found between sporadic type I and hereditary EC (23). However, recent studies (23a) have shown the HNPCC related ECs to be more poorly differentiated, more often associated with Crohn-like lymphoid infiltrates and more often exhibiting angiolymphatic invasion than its sporadic counterpart.

## 6. MOLECULAR PATHOLOGY OF EC

Numerous recent studies have been published on the molecular pathology of EC (10–12,24). The molecular hallmark of sporadic type I carcinomas is inactivation of the *PTEN* tumor suppressor gene. Loss of *PTEN* function is the most common genetic defect in ECs, especially in the type I variety (10,25). It appears that this nonphysiological loss of *PTEN* may occur in the earliest stages of endometrial carcinogenesis, which can be seen in the persistent estrus of anovulatory women (10,25), thus, suggesting the emergence of a monoclonal population of neoplastic cells ([www.endometrium.org](http://www.endometrium.org)) (26). Studies of *PTEN* in normal endometrium show strong expressions in estrogen-dominated proliferative phase and weaker expression in progesterone-added secretory phase. Thus, it is possible that *PTEN*-deficient tumor cells might have a survival advantage in an estrogen-rich environment (10,24). Besides *PTEN*, other molecular markers include the protooncogenes *bcl-2*, and *bax*, which are overexpressed in these tumors. Features helpful in differentiating high-grade type I tumors from type II tumors are, strong nuclear  $\beta$ -catenin immunostaining in the type I cancers and strong e-cadherin immunostaining in the type II cancers (27). As expected, cell proliferation markers, such as MIB-1 and Ki-67 are usually lower in type I EC compared with the type II EC (Table 2).

Thus, three distinct molecular pathways are seen in the pathogenesis of EC. First, *PTEN* loss in sporadic occurrences of the usual, type I low-grade endometrioid cancers. Second, *p53* mutation in sporadic cases of the rarer, type II high-grade serous cancers. Third, microsatellite instability (MSI), as a result of mutations in several *MMR* genes in the hereditary ECs associated with colorectal carcinoma CRCs in the Lynch syndrome. Table 3 shows a comparison of sporadic and HNPCC-associated ECs.

## 7. MICROSATELLITE INSTABILITY

Although, the hereditary ECs most prevalent in Lynch syndrome can be classified histologically with sporadic type I ECs, the hereditary ECs are characterized by a third molecular mechanism (*supra vide*). These tumors show increased MSI secondary to germline mutations in the *MMR* genes (20). So far, at least 39 types of *MMR* mutations have been found in HNPCC syndrome families, including the more common mutations of *MLH1*, *MSH2*, and *MSH6* (28). Sporadic EC, can also be MSI positive. Studies have shown higher MSI levels (17%) in endometrioid EC as compared with the nonendometrioid cancers (5%) (29). But the specific, frequently occurring *MMR* mutations in sporadic tumors are

**Table 2**  
**Comparative Features of Type I and Type II Endometrial Carcinomas**

	<i>Type I</i>	<i>Type II</i>
Age	Perimenopausal	Late menopause
Clinical features	Unopposed estrogen	None
Prototype histology	Endometrioid	Serous papillary
Precursor lesions	Hyperplasia	EIN
FIGO grade	Low	High
Clinical stage	Low	High
Prognosis	Good	Poor
Hormone receptors	High	Low
<i>PTEN</i> function loss	High	Low
<i>p53</i> mutation	Low	High
MLH/MSH	Approximately 17%	Approximately 5%
MIB, Ki-67 index	Low	High
Bcl-2, Bax function loss	High	Low
B-catenin immunostain	Positive	Negative
E-Cadherin immunostain	Negative	Positive

**Table 3**  
**Comparison of Sporadic and HNPCC-Related Endometrial Carcinomas**

	<i>Sporadic</i>	<i>HNPCC</i>
Average age of onset	55 years	45 years
Prototype histology	Endometrioid	Endometrioid
Survival	Stage dependant	Stage dependant
MSI	Occasional	Frequent
Other carcinomas	Ovary	Colorectal

not yet recognized, and the usual mutations associated with MSI in hereditary EC are not found in the sporadic cancers (29,30). It is postulated that there may be epigenetic inactivation of *MSH1* in sporadic cases, which might not be evident in the usual mutational screens used to query the functional integrity of *MLH1* (10,30,31).

The manner in which MSI influences cell function is extremely complex, and beyond the scope of this chapter. Suffice to say that secondary inactivation of the specific genes may occur by alteration of repeat sequences in the coding regions, epigenetic inactivation of MSI in the regulatory domains, or a hypermutable state in the nonrepeat regions. The overall effect may not be mediated through *PTEN* or *p53* inhibition, as these genes are comparable in both stable and MSI-positive cancers (10,30,31).

MSI is a well-known feature of MMR-driven tumorigenesis of uterine mucosa in sporadic tumors, which show predominantly somatic hypermethylation of *MLH1* (32). The finding of MSI in endometrial hyperplasia and altered protein staining for the *MMR* genes suggest that inactivation of *MMR* genes is an early event in endometrial carcinogenesis.

In the general population, MSI is typically seen more frequently in type I endometrioid carcinomas (17–29%) compared with serous papillary types (5–8%) (20), and MSI was seen more frequently in the tumors of patients younger than 50 years age. This is consistent with younger average age of diagnosis for HNPCC-related ECs. However,

the presence or absence of MSI did not correlate with clinical stage or overall prognosis of these tumors (33). Immunoperoxidase staining for *MMR* genes in HNPCC-related EC tissues showed strong positivity in the tumor foci, but not in the adjacent normal tissues, suggesting a possible clonal population of the malignant cells (34). Interestingly, MLH1 and MSH2 protein losses have been demonstrated in the benign endometrial hyperplasias of HNPCC-related cancer patients, but similar changes were not seen in the endometrial hyperplasias of sporadic cases (35). This may characterize an early event in the pathway of the endometrial carcinogenesis in the HNPCC syndrome patients, and might possibly serve as a helpful marker for early diagnosis of these malignancies (35). To date, not much information is available regarding the prognostic significance of MSI. Although, one study (36) suggests an association of MSI-positive phenotype with higher Fédération Internationale de Gynécologie et d'Obstetrique (FIGO) clinical stage and histological grade, and with mucinous and cribriform patterns, and increased necrosis in the tumors.

de Leeuw et al. (32) studied MSI, which has been observed in CRC and in certain extracolonic malignancies, particularly EC, in the Lynch syndrome. In the study of all EC ( $n = 12$ ) from patients with *MLH1* and *MSH2* germline mutations, de Leeuw et al. observed MSI-high phenotype to involve all types of repeat markers. However, in EC from *MSH6* mutation carriers, only 36% (4 out of 11) demonstrated an MSI-high phenotype. MSI-high phenotype was observed in endometrial hyperplasias from *MSH2* mutation carriers, whereas hyperplasias from *MLH1* mutation carriers exhibited an MSI-stable phenotype. Instability of only the mononucleotide repeat markers was found in both endometrial carcinomas and hyperplasias from *MSH6* mutation carriers in 29 out of 31 (94%) endometrial tumor foci. Correlation found between the variation in the extent and level of MSI and the age of onset of EC suggested differences in the rate of progression. A high frequency of MSI in endometrial hyperplasias was found only in *MSH2* mutation carriers, and might indicate more rapid tumor progression in these patients. de Leeuw et al. concluded that assessment of altered MLH1, MSH2, and MSH6 protein staining combined with MSI analysis can direct the mutation analysis to predict the *MMR* germline mutation in endometrial tumors.

On the other hand, Ichikawa et al. (34) analyzed MSI as well as the immunohistochemical expression of MLH1 and MSH2 proteins, in 20 histologically normal epithelia (12 endometrial and 8 ovarian) and 8 cancers (four endometrial and four ovarian) from 20 individuals who were part of seven unrelated Lynch syndrome families. MSI was observed in endometrial (75%) and ovarian (100%) cancers. However, these investigators did not find a single case that exhibited MSI in histologically normal epithelia of the endometrium or ovary. In their investigation of immunohistochemical expressions of MLH1 and MSH2 proteins in histologically normal epithelia, they found no genetic changes predisposing to malignancy. However, in cancer cases there was a correlation between the expression of MLH1 and MSH2 proteins, the presence of germline mutations in *MLH1* and *MSH2* genes, and the presence of MSI in the tumor. These authors concluded that MSI expression and expression of MLH1 and MSH2 proteins are biomarkers, which have no efficacy for the early detection of endometrial and ovarian malignancy in cancer-unaffected HNPCC germline mutation carriers.

Planck et al. (37) investigated MSI-high phenotype and *MMR* protein expression in a series of patients harboring both EC and CRC. Their findings indicated that double primary malignancies of the colorectum and endometrium at a young age (<50 years)

raised the index of suspicion for the Lynch syndrome. Shannon et al. (8), noted that MSI occurs in 17–32% of sporadic ECs and in 3–17% of sporadic ovarian cancers. He hypothesized that a higher rate of MSI might be found in primary carcinomas of the ovary and the endometrium, which occurred in women with synchronous primary cancers of these organs. However, based on 52 cases of synchronous tumors of the ovary and endometrium from the databases of four gynecological oncology units, Shannon et al. (8) failed to identify MSI-high in this cohort. This led the authors to conclude that synchronous primary ovarian and endometrial carcinomas are unlikely to be part of the HNPCC syndrome unless the family history is compatible with the modified Amsterdam criteria.

Noting that CRC and EC are the two most common cancers in Lynch syndrome, Schwartz et al. (38) reported that MSI-positive EC in Lynch syndrome shows mutations in some of the same genes as does the CRC pathway, including *BAX* (55%), *MSH3* (28%), and *MSH6* (17%). They also detected frameshift mutations in caspase-5, a member of the caspase family of proteases that has a (A)<sub>10</sub> repeat within its coding region, in MSI-positive tumors of the endometrium (28%), colon (62%), and stomach (44%). They suggested from these observations that caspase-5 is a target gene in the MSI pathway to cancer.

## 8. LYNCH SYNDROME MUTATIONS AND EC

Cederquist et al. (39) studied MSI-positive double primary CRC and EC in women of Lynch syndrome kindreds, and found that 14 of the 23 patients with both CRC and EC carried mutations of *MLH1*, *MSH2*, or *MSH6* that likely affect protein function. Five of the mutations (36%) were in *MLH1*, three (21%) in *MSH2*, and six (43%) in *MSH6*. Families that carry *MSH6* mutations have higher proportions of EC than those that carry *MLH1* and *MSH2* mutations. Ten out of 14 patients were diagnosed with cancer before 50 years of age. Carriers of *MSH6* mutations had later mean ages for the diagnoses of both CRC and EC. The mean age of 58 years at which EC was diagnosed in *MSH6* mutation carriers contrasted with the mean age of 48 years at which EC was diagnosed in *MLH1* and *MSH2* mutation carriers.

Mutation of *MSH6* merits special attention when considering its role in the Lynch syndrome in general and EC in particular. Hendriks et al. (40) investigated the cumulative risk for cancer in a large series of *MSH6* mutation carriers and compared them with *MLH1* and *MSH2* mutation carriers. This study found that, for female *MSH6* mutation carriers, the cumulative risk of 71% by age 70 years for EC, exceeded the 30% cumulative risk for CRC by this age. Although, the risk for CRC was significantly lower in female *MSH6* mutation carriers than in female *MLH1* or *MSH2* mutation carriers, the risk for EC was significantly higher ( $p = 0.02$ ) in *MSH6* carriers compared with carriers of *MLH1* and *MSH2* mutations.

## 9. ORGAN SITE CANCER SELECTION

Kuismanen et al. (41) noted that the genetic basis of organ susceptibility to malignant transformation is poorly understood in the Lynch syndrome. Given the fact that carcinogenesis in this disorder is driven by defective MMR DNA, these investigators compared instability at microsatellite sequences in the endometrium and colorectum, the two organs most commonly affected in this disorder. They analyzed patients with identified predisposing *MLH1* or *MSH2* MMR gene mutations for noncoding (*BAT25*,

*BAT26*, *BAT40*) and coding mononucleotide repeats in the *MSH6*, *MSH3*, *MLH3*, *BAX*, *IGF2R*, *TGF $\beta$ RII*, and *PTEN* genes, in addition to *MLH1*- and *MSH2*-linked dinucleotide repeats (D3S1611 and CA7). Their findings disclosed significant quantitative and qualitative differences between the two tumor types. Whereas CRCs displayed a predominant pattern consisting of instability at the *BAT* loci (in 89% of tumors), *TGF $\beta$ RII* (73%), dinucleotide repeats (70%), *MSH3* (43%), and *BAX* (30%), no such single pattern was discernable in ECs. Instead, the pattern was more heterogeneous, with a lower proportion of unstable markers per tumor (mean 0.27 for ECs vs 0.45 for CRCs,  $p < 0.001$ ) and shorter allelic shifts for *BAT* markers (average 5.1 bp for unstable ECs vs 9.3 bp for CRCs,  $p < 0.001$ ). Among the individual putative target loci, *PTEN* instability was associated with ECs, and *TGF $\beta$ RII* instability was associated with CRCs. These findings led the authors to conclude that the instability profile of EC differs from that of CRC, even though an identical genetic predisposition underlies the organ-specific differences that are crucial determinants of the Lynch syndrome tumor spectrum.

## 10. HORMONES AND EC

Studies by Sasaki et al. (42) contend that the metabolic activation of estradiol is a key factor in endometrial carcinogenesis. Particular attention was given to the role of 4-hydroxy estrogen metabolites that result from catalytic effects directed by the *CYP1B1* gene in the malignant transformation of endometrium. Specifically, 4-hydroxy estrogens can bind with DNA through a pathway involving their quinone metabolites, which then contribute to oxidative damage, and they have estrogenic effects on the endometrium through their binding with ER sites. The highest level of CYP1B1 expression is in the endometrium. Six polymorphisms of the *CYP1B1* gene have been described of which four result in amino acid substitutions: 1-13C→T, codon 48C→G, codon 119 G→T, codon 432C→G, codon 449T→C, and codon 453A→G. Polymorphisms on exons 2 and 3 have significant effects on the catalytic function of CYP1B1. These authors concluded that inherited alterations in CYP1B1 hydroxylation activity appear to be associated with significant pathogenic alterations in the pathway involved in estrogen-mediated carcinogenesis in the endometrium.

In another study, Sasaki et al. (43) investigated polymorphic CAG repeats in the N-terminal domain, which are contained in the human androgen receptor (*AR*) gene and, which influence transcription efficiency. Because androgens have an antiproliferative effect on endometrial cells, the authors hypothesize that the length of CAG repeats on the *AR* gene may be a predictor for an increased incidence of EC. To test this hypothesis the distributions of CAG repeats on *AR* gene polymorphisms were investigated in EC patients and healthy controls. Genotyping revealed that the distribution of CAG repeats was significantly longer in EC patients than in normal healthy controls ( $p < 0.001$ ). The longer CAG repeats on the *AR* gene may contribute to a decrease in the transactivation function in the receptor and thereby weaken an antiproliferative effect on endometrial cells and promote carcinogenesis.

## 11. CLINICAL CHARACTERISTICS OF EC IN LYNCH SYNDROME

ECs occurring in the Lynch syndrome setting show some distinctive features. Unlike sporadic ECs hereditary EC occurs more commonly among younger women. Fifty-seven



percent of hereditary ECs are diagnosed in women younger than 50 years of age. The average age of HNPCC-related EC is 48 years (range 27–72 years), compared with an average age of 55 years in sporadic EC (44). Sixty-one percent of EC in Lynch syndrome germline mutation carriers occurred with second primary CRCs, and 15% occurred with a third primary tumor (44).

## 12. AGE OF EC DIAGNOSIS IN LYNCH SYNDROME

Data from an international collaborative study of 125 cases of EC collected from HNPCC registries in Western Europe, the United States, and Japan, found that the mean age for diagnosis of this cancer was 48 years (44). A review of 120 HNPCC syndrome families registered in the Familial Bowel Cancer Service of The Royal Melbourne Hospital in Melbourne, Australia, also reported a mean age of 48 years for the diagnosis of EC (45). This mean age of EC in HNPCC kindreds is significantly younger than the 63 years mean age of uterine corpus cancer diagnosis reported by FIGO (46).

A study of 23 unrelated HNPCC syndrome families in the Creighton University Hereditary Cancer Institute registry found that the median age for EC diagnosis was 46 years, which was 14 years younger than the median age of EC reported by the National Institutes of Health Surveillance, Epidemiology and End Results (NIH-SEER) program (4,47). The international collaborative study of 125 patients with EC from HNPCC syndrome families, found that 98% of the ECs were diagnosed in women younger than 65 years, and 57% were diagnosed before the age of 50 years (44). Several members of HNPCC syndrome kindreds documented in these studies were diagnosed with EC as early as their third decades of life (4,44,45). Not only were the mean and median ages younger for the diagnosis of hereditary EC compared with sporadic EC, but, as noted in the studies of Hemminki et al. (48), when EC was diagnosed before the age of 50 years in mothers recorded by the Swedish Cancer Registry, the risk for EC in daughters was increased nearly by 10-fold.

## 13. OVARIAN CANCER AND EC

Excess ovarian cancers have been associated with familial EC (4,45). In a recent study of 19,175 women with invasive ovarian cancer in the nationwide Swedish Family-Cancer Database, Hemminki and Granström calculated standardized incidence ratios (SIRs) for ovarian cancer of 1.45 if mothers had EC and 2.53 when sisters were affected with EC (49). The SIR for endometrioid ovarian carcinoma was 3.40 when mothers had EC. These results confirmed earlier observations by Watson et al. (50), which showed that ovarian cancers associated with HNPCC syndrome were predominantly epithelial tumors with an unusually large proportion being endometrioid and clear cell carcinomas, both of which are histological types that also arise from endometrium (50). In this international collaborative study of women who were known, presumed (based on cancer status), or considered at high-risk (based on pedigree position) to be mutation carriers from HNPCC syndrome families, 94% of the ovarian neoplasms were epithelial tumors (50). Endometrioid (18.3%) and clear cell (9.9%) carcinomas together included 28.2% of the invasive ovarian epithelial cancers in 71 women with recorded histologies (50). These ratios of endometrioid carcinoma or clear cell carcinoma individually and combined, considerably exceeded the 13.2% combined total of endometrioid (9.6%)

and clear cell (3.6%) ovarian carcinomas in general population studies reported from the NIH-SEER program. Also, the 20% combined total of endometrioid (14%) and clear cell (6%) ovarian carcinomas reported by FIGO (51,52). A case-control study by Schildkraut and Thompson (53) of 493 epithelial ovarian cancer cases against 2465 control subjects, found that an increased risk (odds ratio = 2.7, 95%CI = 1–6.9) for endometrioid ovarian carcinoma was associated with family history of EC. Borderline ovarian tumors made up just 4.1% of the epithelial ovarian neoplasms in HNPCC mutation carriers in the international collaborative study compared with 10.4% of the sporadic ovarian neoplasms reported by FIGO (50,52).

Women from HNPCC syndrome kindreds who developed ovarian cancer, were diagnosed at 43 years mean age (50). This was at least 16 years younger than the mean age for the diagnosis of ovarian cancer reported by the NIH-SEER program in the general population of the United States and 13 years younger than the mean age reported by FIGO (51,52). The total proportion (72.2%) of well-differentiated (30.6%) and moderately well-differentiated (41.7%) carcinomas in the international collaborative study of ovarian neoplasms in women from HNPCC syndrome kindreds did not significantly differ from the total proportion (76.6%) of well-differentiated (42.5%) and moderately well-differentiated (34%) carcinomas in the FIGO data (51,53). Most of the ovarian carcinomas diagnosed in HNPCC syndrome kindreds were still confined to the ovary (Stage I, 60.9%) or not extending beyond the gynecological organs and pelvic peritoneum (Stage II, 41.7%) in marked contrast to only 26% Stage I and 10.2% Stage II carcinomas reported by FIGO data (50,52). The relatively earlier age and lower stage of ovarian cancer diagnosis in members of HNPCC syndrome families may reflect a unique genesis of these tumors. Or, on the other hand, these findings might be a result of the early discovery of some unexpected ovarian cancers during surveillance for CRC and EC. Because of known or suspected increased cancer risk or the coincidental finding of early ovarian cancers at the time of therapeutic or prophylactic surgery for CRC and/or EC in the high-risk patients.

The 5-year survival rate for carcinomas that were diagnosed, although still confined to the ovary in women from HNPCC syndrome families (85%) was commensurate with the 5-year survival rate for Stage I cancers in the FIGO data (83%). But, as yet unexplained, women with Stage III ovarian carcinoma from HNPCC syndrome families had better prognosis for 5-year survival (42%) than did women with Stage III ovarian carcinoma patients reported by FIGO (26%) (50). This may simply reflect the small number of patients with ovarian carcinoma (9/64) in the data available to the international collaborative HNPCC study group (50). Or there may have been slightly more favorable tumors by stage, more aggressive treatment, or a younger and more physiologically healthy cohort of ovarian cancer patients diagnosed from HNPCC syndrome families in the collaborative study.

#### 14. MULTIPLE PRIMARY CANCERS

Eighteen of the 80 women (22.5%), deemed to be at high risk for HNPCC who were diagnosed with ovarian cancers in the international collaborative study, also had synchronous ECs, and two further patients subsequently developed primary ECs after the diagnosis of ovarian cancer in this group (50). Multiple primary tumors are common findings with hereditary EC (44,48,54–56). Analysis of the NIH-SEER database showed that women with antedating endometrial or ovarian cancers diagnosed before

50 years of age had significantly increased risks for CRC (57). Registry-based studies in Canada also found that the first-degree relatives of women who were diagnosed with double primary CRC and EC younger than age 55, carried a very high relative risk (RR = 30.5, 95%CI = 18.8–46.6) for developing CRC before the age of 55 years (58).

In patients from known or suspected HNPCC kindreds, multiple primary tumors generally are neoplasms that characterize the spectrum of this syndrome, including (besides colorectal, endometrial, and ovarian cancers) especially upper gastrointestinal, hepatobiliary duct, renal pelvis, and ureteral cancers (4,48,59–63). Seventy-five of 113 (61%) EC cases collected from HNPCC registries in seven countries were associated with second primary cancers, 72% of which were CRCs; and in 18/113 (16%) of the EC patients, there were two or more primary cancers (44). When a second primary tumor followed CRC in 1113 patients from the Swedish Family-Cancer Database, 100% of the ECs came from patients that fulfilled the Bethesda criteria for HNPCC syndrome (64). After a previous CRC, the risk for EC was increased 257-fold among the 12 families that fulfilled the Amsterdam criteria for the HNPCC syndrome in this study from the Swedish database (64). Moreover, the first-degree relatives of *MMR* gene mutation carriers with both primary CRC and EC bore a high relative risk (RR = 23.8, 95%CI = 6.4–61) for EC (56). And, although the risk for EC was lower, it remained significant (RR = 5.4, 95%CI = 2–11.7) in the first-degree relatives of mutation negative probands with both primary CRC and EC (56).

Investigations of EC utilizing some 9.6 million individuals from the Swedish Family-Cancer Database (48), included a subset of 20,000 cases of EC, among which there were 76 families in which both the mother and daughter were affected. This consisted of a familial SIR of 3.19 for daughters and 2.78 for mothers. The risk was inversely related to the age at diagnosis, reaching a risk of almost 10 in daughters who were diagnosed before age of 50 years when their mothers were also diagnosed before that age. The discordant primary cancer site most associated with EC between the two generations was colon, with a SIR of 1.44–1.68. When the maternal EC was diagnosed before age of 50 years, increased SIRs were observed in daughters or sons for rectal, pancreatic, breast, ovarian, and nervous system cancers. Second primary cancers with the highest overall risks in females diagnosed with EC were ovarian and connective tissue cancers with CRCs, also clearly in excess.

## 15. SURVEILLANCE AND SURGICAL PROPHYLAXIS

An absolute identification of women at increased genetic risk for EC may be difficult in the absence of detailed pedigrees and molecular evidence of which the *sine qua non* is a cancer-linked *MMR* gene mutation. Clearly, patients from family pedigrees with tumor spectrums that match the characteristic criteria for HNPCC syndrome are at definably high risk of developing EC. However, unless a woman is delineated by analysis of her extended family cancer pedigree to be an obligatory carrier of the adverse autosomal dominant trait or by DNA testing she is confirmed to carry the known *MMR* gene mutation associated with cancer in her family, hereditary susceptibility to EC will be little more than a conjecture. Nonetheless, through observations from the forgoing review of the pertinent literature on the hereditary aspects of EC, certain management strategies for individuals known or expected to be at increased genetic risk for this disease can be counseled and recommended.

Besides individuals who are found to carry cancer-associated *MMR* gene mutations, and family members in a direct line of descent from HNPCC syndrome affected, women who have been diagnosed with CRC at younger ages, and those with multiple cases of colorectal, endometrial, and ovarian cancer in close relatives, should be considered at risk for EC (7). First-degree relatives of patients diagnosed with EC and CRC at younger than 50 years of age must be suspected to be at heightened risk for cancers of the HNPCC syndrome. As it has been seen from the discussion of pathology (*supra vide*), the typical EC associated with hereditary predisposition is a type I carcinoma, characterized by the presence of ERs and PRs and hyperplastic precursors. Recent studies have demonstrated rather frequent MSI positivity and loss of markers for *MMR* genes in endometrial hyperplasias and carcinomas, but not in normal endometrium from patients deemed to be at genetic risk for endometrial carcinoma (35,65–67). If these data are substantiated in further and expanded investigations, when practical tests become more commonly available to clinically examine endometrial hyperplasias for evidence of MSI and the loss of *MMR* gene markers, patients who are members of families with EC clusters may be considered for this testing.

Because of the very early ages at which endometrial and ovarian cancers have been manifested in patients with a proven or a likely increased hereditary risk for these diseases (4,44,45,50,68), it is believed that baseline studies and then interval transvaginal pelvis ultrasound scans and endometrial cytological and histological screening are appropriate, beginning in the fourth decade of life (69,70). Although, the mean and median ages at which endometrial and ovarian cancers have been diagnosed in women from HNPCC kindreds lie in the fifth decade of life (4,44,45,50,68), as long as the uterus and ovaries are retained, surveillance ought to continue with alertness to symptoms and signs and judicious screening well into the eighth decade and beyond because of the persisting risk for gynecological cancers (44,45,50,68). In the context of thorough cancer genetics counseling, prophylactic surgery will be an alternative chosen by some women with high genetic risk for EC (71–73).

Members of HNPCC syndrome kindreds who are shown through DNA testing to carry the deleterious mutations associated with cancer in their families, and those who are demonstrated by pedigree analysis to be obligate mutation carriers, should be offered the consideration of prophylactic surgery. Other women assessed to be at significantly increased risk for EC, by analysis of their pedigrees, and in the future women who may be found to have endometrial hyperplasia with MSI or abnormal *MMR* gene function may be considered for prophylactic surgery. It is believed that appropriate prophylactic surgery in these patients should include not only hysterectomy but also bilateral salpingo-oophorectomy, because of the high risk for ovarian carcinoma. Additionally, members of HNPCC syndrome kindreds who have already developed cancer of a target organ as young women are, candidates for prophylactic surgery. As it has been noted, besides EC in women, CRC is by far the most frequently encountered malignancy in the Lynch syndrome. Therefore, when CRC is diagnosed and surgically treated in women from HNPCC syndrome families, serious consideration should be given to combining this operation with hysterectomy–salpingo-oophorectomy, if childbearing has been completed or surely by the fifth decade of life. Certainly, no extirpative surgery for EC should be undertaken without a thorough preoperative work-up to rule-out CRC and other target organ cancers of HNPCC syndrome, particularly ovarian carcinoma.

Unless laparotomy is indicated for coexisting indications, when prophylactic hysterectomy–salpingo-oophorectomy is done in women at hereditary risk (71), it has been found that peritoneal exploration is maximized and complications are minimized by employing video-laparoscopic techniques (74,75). These procedures permit meticulous inspection of most of the peritoneal cavity and its organs, collection of fluid for cytology, biopsies of any suspicious lesions, visualization, and dissection of the ovaries and fallopian tubes, and removal of the adnexal organs *en bloc* with transvaginal hysterectomy (71,76).

## 16. DISCUSSION

One of the earliest studies of hereditary EC (77–78) involved 154 consecutive patients, all of whom were histologically confirmed. They were seen over a 20-year period (1946–1965). Obesity was the most frequently occurring constitutional factor in this series of patients with EC, being present in 123 (80%) of the 154 patients. Obesity was extreme in many of the patients, with several weighing more than 300 pounds and two of those weighing more than 400 pounds. Hypertension was present in 65% and diabetes mellitus was present in 43% of these patients.

Twenty-six patients (16%) had first-degree relatives with EC. The finding of 16% of the probands whose first-degree relatives had EC is conservative. Rigorous documentation, either through personal examination of tissues or evaluation of pathology reports, or highly reliable information from physicians were the criteria, which are required for family members to be included with a diagnosis of EC. In one of the families, three sisters had EC histologically confirmed. Two of the families had a mother and daughter with histologically confirmed EC. In two of the families, sisters had histologically confirmed EC. The average age of EC in multicase families was 50 years, contrasted with an average age of 63 years in probands of the EC series overall.

Multiple primary cancers were found in 17 patients (11%), and five of these individuals had three primary malignant neoplasms. When one of the cancers was EC, carcinoma of the colon was the most frequently associated extra-EC primary malignant neoplasm. This finding was in striking contrast to the probands of the overall EC series in which no patients with multiple primary cancers had carcinoma of the colon as their associated extra-EC primary malignancy.

Previous studies of EC had been primarily concerned with selective evaluation of patients for the related incidences of obesity, diabetes mellitus, endometrial hyperplasia, hypertension, cardiovascular disease, parity, and other constitutional associations (79,80) as well as a study of hereditary factors (14,81,82). The 11% incidence of multiple primary malignancies in the series was not significantly different from that of Moertel and associates (83) who found an incidence of 9.9% of multiple primary malignancies in their study of 807 patients with EC. These investigators found carcinoma of the breast to be the primary cancer most frequently associated with EC. They found CRC as a separate primary site in 14% of their EC patients. Therefore, it was of interest that none of the probands in the EC series showed carcinoma of the colon as a separate primary site; yet, this was the most frequent site for a second primary in patients with EC in “cancer families,” which demonstrated early ages of onset and multiple cancers. These studies were an early indication that EC in some cases is a heritable disease (84).

Besides the inheritance of adverse germline mutations of *MMR* genes, other hereditary predispositions to EC could result from genetic defects of the endocrine system, such as Stein–Leventhal syndrome leading to anovulation and excess unopposed estrogen stimulation of the endometrium (85). Any inherited defect in the hypothalamic–pituitary–ovarian axis or defective thyroid or adrenal function could result in anovulation and unopposed estrogenic milieu leading to endometrial hyperplasia. It is speculated that such endocrinopathies could predispose to type I EC by serving as cofactors in women who are more susceptible to malignant transformation because they also carry defective *MMR* genes.

## 17. CONCLUSION

In conclusion, the multifaceted etiology and pathogenesis of EC have been described with major attention to its association with the Lynch syndrome. It is clear from this review that only the tip of the proverbial iceberg concerning hereditary EC has been glimpsed.

## REFERENCES

1. Jemal A, Tiwari RC, Murray T, et al. Cancer statistics 2004. *CA Cancer J Clin* 2004; 54: 8–29.
2. Lynch HT, de la Chapelle A. Genetic susceptibility to non-polyposis colorectal cancer. *J Med Genet* 1999; 36: 801–818.
3. Lynch HT, de la Chapelle A. Genomic medicine: hereditary colorectal cancer. *N Engl J Med* 2003; 348: 919–932.
4. Watson P, Lynch HT. Extracolonic cancer in hereditary nonpolyposis colorectal cancer. *Cancer* 1993; 71: 677–685.
5. Lynch HT, Lynch J, Conway T, Watson P, Coleman RL. Familial aggregation of carcinoma of the endometrium. *Am J Obstet Gynecol* 1994; 171: 24–27.
6. Lynch HT, Snyder CL, Lynch JF, Riley BD, Rubinstein WS. Hereditary breast-ovarian cancer at the bedside: role of the medical oncologist. *J Clin Oncol* 2003; 21: 740–753.
7. Lynch HT, Cavalieri RJ, Lynch JF, Casey MJ. Gynecologic cancer clues to Lynch syndrome II diagnosis: a family report. *Gynecol Oncol* 1992; 44: 198–203.
8. Shannon C, Kirk J, Barnetson R, et al. Incidence of microsatellite instability in synchronous tumors of the ovary and endometrium. *Clin Cancer Res* 2003; 9: 1387–1392.
9. Chung L, Broaddus R, Crozier M, Luthraa R, Levenback C, Lu K. Unexpected endometrial cancer at prophylactic hysterectomy in a woman with hereditary nonpolyposis colon cancer. *Obstet Gynecol* 2003; 102: 1152–1155.
10. Mutter GE. Molecular pathogenesis of endometrial cancer. International Society of Gynecologic Pathologists, Companion Meeting Syllabus. Annual meeting of the United States and Canadian Academy of Pathologists; 2003 March 22–28; Washington, DC. United States and Canadian Academy of Pathologists 2003, pp. 59–72.
11. Mutter GL. Pten, a protean tumor suppressor. *Am J Pathol* 2001; 158: 1895–1898.
12. Matias-Guiu X, Catusas L, Bussaglia E, et al. Molecular pathology of endometrial hyperplasia and carcinoma. *Hum Pathol* 2001; 32: 569–577.
13. Way SA. The aetiology of carcinoma of the body of the uterus. *J Obstet Gynaecol Br Comm* 1954; 61: 46–58.
14. Murphy DP. Heredity in Uterine Cancer. Cambridge MA: Harvard University Press, 1952.
15. Ivanovich J, Babb S, Goodfellow P, et al. Evaluation of the family history collection process and the accuracy of cancer reporting among a series of women with endometrial cancer. *Clin Cancer Res* 2002; 8: 1849–1856.
16. Nyholm HCJ, Nielsen AL, Norup P. Endometrial cancer in postmenopausal women with and without previous estrogen replacement treatment: Comparison of clinical and histopathological characteristics. *Gynecol Oncol* 1993; 49: 229–235.
17. Chambers JT, Carcangiu ML, Voynick IM, Schwartz PE. Immunohistochemical evaluation of estrogen and progesterone receptor content in 183 patients with endometrial carcinoma. Part II:

- Correlation between biochemical and immunohistochemical methods and survival. *Am J Clin Pathol* 1990; 94: 255–260.
18. Kadar N, Malfetano JH, Homesley HD. Steroid receptor concentrations in endometrial carcinoma: effect on survival in surgically staged patients. *Gynecol Oncol* 1993; 50: 281–286.
  19. Sherman ME. Theories of endometrial carcinogenesis: a multidisciplinary approach. *Mod Pathol* 2000; 13: 295–308.
  20. Sherman ME, Kurman RJ. Evolving concepts in endometrial carcinogenesis: importance of DNA repair and deregulated growth. *Hum Pathol* 1998; 29: 1035–1038.
  21. McCluggage WG. Immunohistochemistry of endometrial cancer. International Society of Gynecologic Pathologists, Companion Meeting Syllabus. Annual meeting of the United States and Canadian Academy of Pathologists; 2003 March 22–28; Washington, DC. United States and Canadian Academy of Pathologists 2003, pp. 49–58.
  22. Goldstein NS, Uzieblo A. WT1 immunoreactivity in uterine papillary serous carcinomas is different from ovarian serous carcinomas. *Am J Clin Pathol* 2002; 117: 541–545.
  - 22a. Herman JG, Baylin SB. Gene silencing in cancer in association with promoter hypermethylation. (Mechanisms of Disease). *N Engl J Med* 2003; 349: 2042–2054.
  23. Ronnett BM, Zaino RJ, Ellenson LH, Kurman RJ. Chapter 12, in *Blaustein's Pathology of the Female Genital Tract* (Kurman RJ, ed.), New York, NY: Springer-Verlag Publishers, 2002, pp. 501–536.
  - 23a. van den Bos M, van den Hoven M, Jonhegan E, et al. More differences between HNPCC-related and sporadic carcinomas from the endometrium as compared to the colon. *Am J Surg Pathol* 2004; 28: 706–711.
  24. Mutter GL, Lin MC, Fitzgerald JT, Kum JB, Eng C. Changes in endometrial PTEN expression throughout the human menstrual cycle. *J Clin Endocrinol Metab* 2000; 85: 2334–2338.
  25. Mutter GL. Histopathology of genetically defined endometrial precancers. *Int J Gynecol Pathol* 2000; 19: 301–309.
  26. Mutter GL. Endometrium.org. Brigham and Women's Hospital, Harvard Medical School. Available at: URL:<http://www.endometrium.org>. Accessed August 16, 2004.
  27. Schlosshauer PW, Ellenson LH, Soslow RA. Beta-catenin and E-cadherin expression patterns in high-grade endometrial carcinoma are associated with histological subtype. *Mod Pathol* 2002; 15: 1032–1037.
  28. Nilbert M, Gronberg H, Lindblom A. Essential to discover hereditary colorectal and endometrial cancer. Mutations in “HNPCC individuals” can cause several different tumors. *Lakartidningen* 2002; 99: 3296–3300.
  29. Faquin WC, Fitzgerald JT, Lin MC, Boynton KA, Muto MG, Mutter GL. Sporadic microsatellite instability is specific to neoplastic and preneoplastic endometrial tissues. *Am J Clin Pathol* 2000; 113: 576–582.
  30. Esteller M, Levine R, Baylin SB, Ellenson LH, Herman JG. *MLH1* promoter hypermethylation is associated with the microsatellite instability phenotype in sporadic endometrial carcinomas. *Oncogene* 1998; 17: 2413–2417.
  31. Kowalski LD, Mutch DG, Herzog TJ, Rader JS, Goodfellow PJ. Mutational analysis of *MLH1* and *MSH2* in 25 prospectively-acquired RER+ endometrial cancers. *Genes Chromosomes Cancer* 1997; 18: 219–227.
  32. de Leeuw WJ, Dierssen J, Vasen HF, et al. Prediction of a mismatch repair gene defect by microsatellite instability and immunohistochemical analysis in endometrial tumours from HNPCC patients. *J Pathol* 2000; 192: 328–335.
  33. Catusus L, Machin P, Matias-Guiu X, Prat J. Microsatellite instability in endometrial carcinomas: clinicopathologic correlations in a series of 42 cases. *Hum Pathol* 1998; 29: 1160–1164.
  34. Ichikawa Y, Lemon SJ, Wang S, et al. Microsatellite instability and expression of *MLH1* and *MSH2* in normal and malignant endometrial and ovarian epithelium in hereditary nonpolyposis colorectal cancer family members. *Cancer Genet Cytogenet* 1999; 112: 2–8.
  35. Berends MJW, Hollema H, Wu Y, et al. *MLH1* and *MSH2* protein expression as a pre-screening marker in hereditary and non-hereditary endometrial hyperplasia and cancer. *Int J Cancer* 2001; 92: 398–403.
  36. Parc YR, Halling KC, Burgart LJ, et al. Microsatellite instability and h*MLH1*/h*MSH2* expression in young endometrial carcinoma patients: associations with family history and histopathology. *Int J Cancer* 2000; 86: 60–66.

37. Planck M, Rambech E, Moslein G, Muller W, Olsson H, Nilbert M. High frequency of microsatellite instability and loss of mismatch-repair protein expression in patients with double primary tumors of the endometrium and colorectum. *Cancer* 2002; 94: 2502–2510.
38. Schwartz S Jr, Yamamoto H, Navarro M, Maestro M, Reventos J, Perucho M. Frameshift mutations at mononucleotide repeats in caspase-5 and other target genes in endometrial and gastrointestinal cancer of the microsatellite mutator phenotype. *Cancer Res* 1999; 59: 2995–3002.
39. Cederquist K, Emanuelsson M, Göransson I, et al. Mutation analysis of the *MLH1*, *MSh2* and *MSh6* genes in patients with double primary cancers of the colorectum and the endometrium: a population-based study in Northern Sweden. *Int J Cancer* 2004; 109: 370–376.
40. Hendriks YMC, Wagner A, Morreau H, et al. Cancer risk in hereditary nonpolyposis colorectal cancer due to *MSh6* mutations: impact on counseling and surveillance. *Gastroenterology* 2004; 127: 17–25.
41. Kuismanen SA, Moisio AL, Schweizer P, et al. Endometrial and colorectal tumors from patients with hereditary nonpolyposis colon cancer display different patterns of microsatellite instability. *Am J Pathol* 2002; 160: 1953–1958.
42. Sasaki M, Kaneuchi M, Fujimoto S, Tanaka Y, Dahiya R. CYP1B1 gene in endometrial cancer. *Mol Cell Endocrinol* 2003; 202: 171–176.
43. Sasaki M, Sakuragi N, Dahiya R. The CAG repeats in exon 1 of the androgen receptor gene are significantly longer in endometrial cancer patients. *Biochem Biophys Res Commun* 2003; 305: 1105–1108.
44. Vasen HFA, Watson P, Mecklin J-P, et al. The epidemiology of endometrial cancer in hereditary nonpolyposis colorectal cancer. *Anticancer Res* 1994; 14: 1675–1678.
45. Brown GJ, St. John DJ, Macrae FA, Aittomaki K. Cancer risk in young women at risk of hereditary nonpolyposis colorectal cancer: implications for gynecologic surveillance. *Gynecol Oncol* 2001; 80: 346–349.
46. Creasman W, Odincino F, Maisonneuve P, et al. Carcinoma of the corpus uteri. *J Epidemiol Biostat* 1998; 3: 35–61.
47. Demographic Analysis Section DoCCaPNCI. Surveillance, epidemiology, and end results: incidence and mortality data, 1973–1977 (Young JL Jr, Percy CL, Asire AJ ed.). NIH Publication No. 81-2330, 1981, 66–88. Bethesda, Maryland, US. Department of Health and Human Services, Public Health Service, National Institutes of Health, National Cancer Institute. National Cancer Institute Monograph 57.
48. Hemminki K, Vaittinen P, Dong C. Endometrial cancer in the Family-Cancer Database. *Cancer Epidemiol Biomarkers Prev* 1999; 8: 1005–1010.
49. Hemminki K, Granström C. Familial clustering of ovarian and endometrial cancers. *Eur J Cancer* 2004; 40: 90–95.
50. Watson P, Bützow R, Lynch HT, et al. The clinical features of ovarian cancer in hereditary nonpolyposis colorectal cancer. *Gynecol Oncol* 2001; 82: 223–228.
51. Kosary CL. FIGO stage, histology, histologic grade, age and race as prognostic factors in determining survival for cancers of the female gynecological system: an analysis of 1973–1987 SEER cases of cancers of the endometrium, cervix, ovary, vulva, and vagina. *Sem Surg Oncol* 1994; 10: 31–46.
52. Pecorelli S, Odicino F, Maisonneuve P, et al. Carcinoma of the ovary. *J Epidemiol Biostat* 1998; 3: 75–102.
53. Schildkraut JM, Thompson WD. Relationship of epithelial ovarian cancer to other malignancies within families. *Genet Epidemiol* 1988; 5: 355–367.
54. Hakala T, Mecklin JP, Forss M, Jarvinen H, Lehtovirta P. Endometrial carcinoma in the cancer family syndrome. *Cancer* 1991; 68: 1656–1659.
55. Aarnio M, Mecklin JP, Aaltonen LA, Nystrom-Lahti M, Jarvinen HJ. Life-time risk of different cancers in hereditary non-polyposis colorectal cancer (HNPCC) syndrome. *Int J Cancer* 1995; 64: 430–433.
56. Millar AL, Pal T, Madlensky L, et al. Mismatch repair gene defects contribute to the genetic basis of double primary cancers of the colorectum and endometrium. *Hum Mol Genet* 1999; 8: 823–829.
57. Weinberg DS, Newschaffer CJ, Topham A. Risk for colorectal cancer after gynecologic cancer. *Ann Intern Med* 1999; 131: 189–193.
58. Pal T, Flanders T, Mitchell-Lehman M, et al. Genetic implications of double primary cancers of the colorectum and endometrium. *J Med Genet* 1998; 35: 978–984.
59. Vasen HFA, Offerhaus GJA, Den Hartog Jager FCA, et al. The tumor spectrum in hereditary nonpolyposis colorectal cancer: a study of 24 kindreds in the Netherlands. *Int J Cancer* 1990; 46: 31–34.



60. Vasen HFA, Wijnen JT, Menko FH, et al. Cancer risk in families with hereditary nonpolyposis colorectal cancer diagnosed by mutation analysis. *Gastroenterology* 1996; 110: 1020–1027.
61. Wijnen JT, Vasen HFA, Khan PM, et al. Clinical findings with implications for genetic testing in families with clustering of colorectal cancer. *N Engl J Med* 1998; 339: 511–518.
62. Aarnio M, Sankila R, Pukkala E, et al. Cancer risk in mutation carriers of DNA-mismatch-repair genes. *Int J Cancer* 1999; 81: 214–218.
63. Cederquist K, Golovleva I, Emanuelsson M, Stenling R, Grönberg H. A population-based cohort study of patients with multiple colon and endometrial cancer: correlation of microsatellite instability (MSI) status, age at diagnosis and cancer risk. *Int J Cancer* 2001; 91: 486–491.
64. Hemminki K, Li X, Dong C. Second primary cancers after sporadic and familial colorectal cancer. *Cancer Epidemiol Biomarkers Prev* 2001; 10: 793–798.
65. Maruyama A, Saito T, Hachitanda Y, Tsukamoto N. Cancer history and loss of MSH2 and MSH1 protein expression in patients with endometrial hyperplasia. *Int J Gynecol Cancer* 2003; 13: 352–360.
66. Orbo A, Nilsen MN, Arnes MS, Pettersen I, Larsen K. Loss of expression of MLH1, MSH2, MSH6, and PTEN related to endometrial cancer in 68 patients with endometrial hyperplasia. *Int J Gynecol Pathol* 2003; 22: 141–148.
67. Sutter C, Dallenbach-Helweg G, Schmidt D, et al. Molecular analysis of endometrial hyperplasia in HNPCC-suspicious patients may predict progression to endometrial carcinoma. *Int J Gynecol Pathol* 2004; 23: 18–25.
68. Watson P, Vasen HFA, Mecklin J-P, Jarvinen H, Lynch HT. The risk of endometrial cancer in hereditary nonpolyposis colorectal cancer. *Am J Med* 1994; 96: 516–520.
69. Burke W, Petersen G, Lynch P, et al. Recommendations for follow-up care of individuals with an inherited predisposition to cancer: I. Hereditary nonpolyposis colon cancer. *JAMA* 1997; 277: 915–919.
70. Rijcken FE, Mourits MJ, Kleibeuker JH, Hollema H, van der Zee AG. Gynecologic screening in hereditary nonpolyposis colorectal cancer. *Gynecol Oncol* 2003; 91: 74–80.
71. Casey MJ, Bewtra C, Garcia-Padial J, Lynch HT. Laparoscopic examination and assisted bilateral salpingo-oophorectomy hysterectomy for prophylactic removal of the ovaries and uterus in women at genetic risk for ovarian cancer. *J Gynecol Tech* 1995; 1: 111–114.
72. Lynch HT, Watson P, Shaw TG, et al. Clinical impact of molecular genetic diagnosis, genetic counseling, and management of hereditary cancer. Part II: hereditary nonpolyposis colorectal carcinoma as a model. *Cancer* 1999; 86: 2457–2463.
73. Lynch HT, Riley BD, Weismann S, et al. Hereditary nonpolyposis colorectal carcinoma (HNPCC) and HNPCC-like families: problems in diagnosis, surveillance, and management. *Cancer* 2004; 100: 53–64.
74. Casey MJ, Garcia-Padial J, Johnson C, Osborne NG, Sotolongo J, Watson P. A critical analysis of laparoscopic assisted vaginal hysterectomies compared with vaginal hysterectomies unassisted by laparoscopy and transabdominal hysterectomies. *J Gynecol Surg* 1994; 10: 7–14.
75. Casey MJ, Garcia-Padial J, Hakert D, Watson P. Changing trends in surgical approaches to hysterectomy: an analysis of the use of laparoscopic assisted vaginal hysterectomies in clinic practice. *J Gynecol Surg* 1988; 14: 15–24.
76. Garcia-Padial J, Sotolongo J, Casey MJ, Johnson C, Osborne NG. Laparoscopy-assisted vaginal hysterectomy: report of seventy-five consecutive cases. *J Gynecol Surg* 1992; 8: 81–85.
77. Lynch HT, Krush AJ, Larsen AL, Magnuson cW. Endometrial carcinoma: multiple primary malignancies, constitutional factors, and heredity. *Am J Med Sci* 1966; 252: 381–390.
78. Lynch HT, Krush AJ, Larsen AL. Heredity and endometrial carcinoma. *Southern Med J* 1967; 60(3): 231–235.
79. Wynder EL, Escher GC, Mantel N. An epidemiological investigation of cancer of the endometrium. *Cancer* 1966; 19: 489–520.
80. Stewart HL, Dunham LJ, Casper J, et al. Epidemiology of cancers of the uterine cervix and corpus, breast and ovary in Israel and New York City. *J Natl Cancer Inst* 1966; 37: 1–95.
81. Baanders-vanHalewijn EA, de Waard F, Mastboom JL, Tonkes E, Meinsma L. Constitutional and hereditary aspects of endometrial cancer. *Z Geburtshilfe Gynakol* 1963; 161: 77–93.
82. Brobeck Ø. Heredity in Cancer Uteri: A Genetical and Clinical Study of 200 Patients with Cancer of the Cervix Uteri and 90 Patients with Cancer of the Corpus Uteri. Aarhus, Denmark: Universitetsforlaget, 1949.

83. Moertel CG, Dockerty MB, Baggenstoss AH. Multiple primary malignant neoplasms. II. Tumors of different tissues or organs. *Cancer* 1961; 14: 231–237.
84. Lynch HT, Shaw MW, Magnuson CW, Larsen AL, Krush AJ. Hereditary factors in cancer: study of two large Midwestern kindreds. *Arch Intern Med* 1966; 117: 206–212.
85. Dockerty MB, Jackson RL. The Stein-Levinthal syndrome: analysis of 43 cases with special reference to association with endometrial carcinoma. *Am J Obstet Gynecol* 1957; 73: 161–173.

---

**VII** THE MULTIDISCIPLINARY THERAPEUTIC  
APPROACH TO GYNECOLOGICAL  
CANCER IN THE NEW MILLENIUM

---

# 13

---

## The Holistic Approach to Female Cancer Patients

---

*Alessandro Bovicelli, MD, PhD,  
Pier Paolo Claudio, MD, PhD,  
and Antonio Giordano, MD, PhD*

---

For years, the doctor has fundamentally been an autonomous professional figure. He took care of his patients, carried out diagnostic investigations, and did the autopsies when the inevitable happened—a clinician and a pathologist practically united in one single person. Then, the growth of knowledge, which has taken place in recent years, has profoundly modified the structure of the medical class so that currently, the profession is characterized by the existence of numerous specialties and subspecialties. This has been followed by the creation of distinct professional figures, clinician on the one hand and pathologist on the other, which has contributed in large measure to the growth of knowledge in medicine, which has resulted in large benefits in contrast to some minor problems. In this regard, separating the fields of specialization has determined, in reality, separation of the culture and the language, creating a deep rift. Unfortunately, there are numerous realities, in which the clinician and the pathologist operate in different structures, and therefore, interact very little or not at all.

The surgeon carries out an operation, often sends the specimen accompanied by insufficient clinical indications and this involves a high risk of inaccuracy and also, errors on the part of the pathologist. For example, the diagnosis on an endometrial biopsy can be impossible without information relative to the date of the last menstruation or the assumption of contraceptives up to eventual treatment with substitute therapies. Again, if an endometrial biopsy is carried out for a neoplasia, it is impossible to obtain a pathological diagnosis useful for programming therapy if the pathologist is not informed of the clinical staging and the protocols used pre- and postsurgically.

Finally, in the presence of innovative surgical techniques, the pathologist must be informed about the modality of the operation. The use of endoscopy rather than laparotomy (laparoscopy or hysteroscopy), of laser and/or loops rather than surgical cones provokes artifacts in the tissue, which the pathologist has to be able to recognize and formulate. On the other hand, if the damage to the tissue is significant, the pathologist has to inform the operator, who in turn, will better formulate the aspects of his method. It is also evident, from these simple examples, how, from inadequate clinical information,

an incomplete response of the pathologist cannot help, and therefore, inevitably offer an often inadequate therapy.

Furthermore, the contribution of the pathologist, even in the light of the indications, which the researcher will furnish using molecular biology and the study of genetics, will always be more strongly determinant in reaching earlier diagnosis, in better defining the prognosis and therapeutic treatment (pharmacological or surgical), and in making them more specific and personalized and, therefore more resolute. New methods and more innovative technology, such as, for example, proteomics and microarray technology, which have begun to be implemented presently, will allow the molecular classification of tumors with analysis of the expression profile of hundreds of genes and proteins in a simultaneous manner. All these are assisted by computer technology. These techniques will determine a superexponential increase of information relative to the genetic expression of a tumor, even if the topographical characteristics of the protein furnished by immunohistochemistry will, of course, remain important.

The substantial difference with respect to traditional histopathological evaluation is that the more global approach furnished by the expression profile using microarray or proteomics could substitute the current diagnosis, which is fundamentally morphological; that is, which would be passed from “morphopathology” to “biopathology.” The molecular profile of more genes and proteins will permit better characterization of neoplasias. Tumors having a similar molecular behavior will have a similar prognosis and a specific response to the therapy. In particular, in gynecology, currently it is possible to identify populations at high risk for developing a mammary or an ovarian neoplasia, thanks to mutation research on the *BRCA1* and *BRCA2* genes. Female carriers do not only have a higher probability of developing these neoplasias, but also of developing them at an earlier age. The study of the genetic set of neoplasias has therefore furnished the theoretical basis for understanding the origin, biological behavior, and response to therapy. Each carcinoma possesses a set of oncogenes, oncosuppressors, and numerous other factors, such as, for example, angiogenetic factors, which determine the various degrees of aggressivity, the age of onset, the means of diffusion, the capacity of survival of the immune system, dependence on the environment, and the alterations at the level of the cell cycle.

Molecular investigation, carried out in detail by the researcher, will permit the identification of subgroups of patients to be treated more or less conservatively, taking into consideration the “state of health” of the genes and the proteins. From this “state of health,” it should be understood precisely, which neoplasias will respond efficaciously to chemotherapy or surgery and which, will not respond. The clinical management of patients should therefore understandably be influenced by this knowledge. The biological distinctiveness of the pathology must modify the attitude of the clinician. It is therefore necessary that medical updating take place at many levels, expanding the horizons of one’s speciality beyond those considered insurmountable until a few years back. In order to completely take advantage of the theoretical results obtained, it is essential that the updating of the clinician is continuous, and completely well rounded with special attention being paid to the achievements of the pathologist and researcher.

In particular, in daily practice, the jobs of the clinician, the pathologist, and the researcher have to be united as much as possible through the creation of mixed units with the same objectives. It is no longer the various specialities, which condition the

creation of work groups, but instead the common fields of interest, which bring together professional figures coming from different fields of interest. Wherever these research units have been constituted, the results are tangible both in terms of clinical care and research. The creation of work groups made up of gynecologists, pathologists, molecular biologists, oncologists, and radiotherapists has profoundly modified the treatment protocols of gynecological neoplasias. Meetings are held weekly during which clinical cases are discussed, problems linked to research under way are addressed, updating takes place in a continuous and reciprocal manner by comparisons with the international literature. Other than the increase in clinical care, this has led to a notable improvement of the quality of teaching offered to residents. Only in this way, through close collaboration, clinical and basic research, and patient care can offer better results.

The way of curing cancer has therefore changed because today research is part of the cure. Because through analysis of the genetic profile of a cancer cell, molecular medicine is capable of reading the cell's capacity of growth and diffusion, and simultaneously, its possible response to medical therapy. Therapy is also research. In addition to personalized and less toxic therapy, innovative therapies have also been introduced because the transfer of research data to the clinic is more rapid. Therefore, this is the era of more scientific and certainly more efficacious medicine, but it inevitably runs the risk of losing its humanity. This is why the journey from the laboratory to the bedside of the patient should also be taken in the opposite direction. The researcher has learned, or will learn, to go into the ward and look into the eyes of the patients because the more you go toward technical and technological medicine, the more you need to nourish empathetic medicine, that of dialog, communication, and attention to the psychological and subjective aspect of the disease. For the doctor, a patient is a body to heal; for the researcher, it is a body to study, but the two attitudes have to coexist. Science cannot cure without research, but medicine cannot neglect its human commitment owing to the impatience of research and innovation. The fine equilibrium between curing and caring for the patient becomes the discriminating factor. When the patient is the focal point, results obtained are, reduction of total mortality from cancer, increase in the rate of healing, and better quality of life for all oncological patients, thanks to the fight against physical pain, which is today treated as a symptom, and psychological pain that causes unnecessary suffering.

---

# Index

---

## A

- AKT2, amplification in ovarian carcinogenesis, 23
- Androgen receptor, polymorphisms in endometrial cancer, 206
- Angiogenesis, cervical cancer, 119
- ApoE, overexpression in ovarian carcinogenesis, 23

## B

- Bax, ovarian cancer prognostic marker, 37
- Bcl-2, ovarian cancer prognostic marker, 37
- BRAF*, mutations in ovarian carcinogenesis, 20—22
- BRCA*,
  - functions
    - BRCA1*, 175—177
    - BRCA2*, 175—177
  - mutation testing, 181
  - ovarian cancer
    - carcinogenesis mutations, 22
    - clinical course with mutations, 178
    - mutations, 174, 175
    - penetrance of mutations, 177, 178
- Breast cancer,
  - breast/ovarian cancer syndrome and *BRCA* mutations, 174—178
  - surveillance, 182

## C

- CA 125, ovarian cancer,
  - early detection marker, 30, 31, 181
  - prognostic marker, 38
- $\beta$ -Catenin,
  - cervical cancer marker, 116
  - endometrial cancer mutations, 79
- CDK, *see* Cyclin-dependent kinase
- Cell cycle,
  - alterations in malignant transformation, 5
  - G1/S phase alterations in cancer
    - cyclin D1, 6
    - cyclin D2, 7
    - cyclin D3, 7
    - cyclin-dependent kinase inhibitors, 7, 8
    - cyclin-dependent kinase-4, 7
    - cyclin E, 6
  - G2/M phase alterations in cancer, 9, 10
  - human papillomavirus oncoprotein effects, 114, 133
  - p53 pathway in cancer, 8
  - prospects for study, 10

- regulation, 3—5
- retinoblastoma protein pathway in cancer, 8, 9
- Cervical cancer, *see also* Human papillomavirus, markers,
  - $\beta$ -catenin, 116
  - cyclooxygenase-2, 118
  - FHIT*, 117p16, 117
  - Her-2/neu, 117, 118
  - keratins, 118—119
  - Ki-67, 117
  - matrix metalloproteinases, 119
  - p53 polymorphisms, 114, 115
  - screening, 107, 108
  - squamous intraepithelial lesion,
    - high-grade, 104, 113, 132, 133
    - low-grade, 104, 105, 108, 109, 113, 132
    - natural history in adolescents, 106, 107
    - triage, 108, 109
- Choriocarcinoma, pathogenesis, 161, 162
- Chorionic-type intermediate trophoblastic cell, features, 159
- Cisplatin, endometrial cancer management, 66
- CKIs, *see* Cyclin-dependent kinase inhibitors
- Colon cancer, *see also* Hereditary nonpolyposis colorectal cancer syndrome,
  - surveillance, 182
- COX-2, *see* Cyclooxygenase-2
- Cyclin D1,
  - cancer alterations, 6
  - ovarian cancer prognostic marker, 37
- Cyclin D2, cancer alterations, 7
- Cyclin D3, cancer alterations, 7
- Cyclin-dependent kinase (CDK),
  - cancer alterations, 7
  - cell cycle control, 3—5
- Cyclin-dependent kinase inhibitors (CKIs),
  - cancer alterations, 7, 8
  - cell cycle control, 3
  - ovarian cancer prognostic markers,
    - p16, 36
    - p21, 36
    - p27, 36
- Cyclin E,
  - cancer alterations, 6
  - ovarian cancer prognostic marker, 37
- Cyclooxygenase-2 (COX-2),
  - cervical cancer marker, 118
  - ovarian cancer chemoprophylaxis, 183, 184
- CYP1B1, polymorphisms in endometrial cancer, 206
- Cytotrophoblast, features, 158

**D**

DNA microarray, ovarian cancer marker development, 39

Doxorubicin, endometrial cancer management, 66

**E**

EGD, *see* Endometrial glandular dysplasia

EIC, *see* Endometrial intraepithelial carcinoma

Endometrial cancer,

adenocarcinoma,

histological classification, 53—56

hormonal risk modulation in type I, 83, 85

*p53* mutations in type II, 74, 75, 85, 95, 202

preinvasive disease, *see* Endometrial glandular dysplasia; Endometrial hyperplasia; Endometrial intraepithelial

carcinoma progression,

endometrioid adenocarcinoma, 64, 65

uterine papillary serous carcinoma, 65

prospects for study, 67, 68

*PTEN* mutations in type I, 74, 75, 83, 85, 92—94, 202

types, 52, 53, 73—75, 92—95, 200—202

carcinogenesis,

emergence of lesions, 79

endometrial intraepithelial carcinoma, *see*

Endometrial intraepithelial carcinoma

preclinical phase, 78, 79

premalignant lesion features, 76, 77

prospects for study, 88

*PTEN* changes, 77, 78, 80, 202

clear cell carcinoma molecular genetics, 96, 97

epidemiology, 51, 52, 195

heredity,

family history taking, 199

hereditary nonpolyposis colorectal cancer syndrome,

age at diagnosis, 207

association, 195—197, 202, 205, 211

clinical characteristics, 206, 207

multiple primary cancers, 208, 209

surveillance and surgical prophylaxis, 209—211

ovarian cancer with familial disease, 207, 208

pedigree analysis, 196, 198, 199

Stein—Leventhal syndrome, 212

syndromes, 75, 76

hormone relationships with molecular genetic

alterations, 97, 98, 206

*MLH1* microsatellite instability, 78, 79, 94, 202—205

mouse models, 98

surveillance, 182

treatment of advanced and recurrent disease, 65—67

uterine cervical carcinoma distinction, 197—199

Endometrial glandular dysplasia (EGD), features and carcinogenesis, 87

Endometrial hyperplasia,

carcinogenesis, 76

classification, 58—60

definition, 57, 58

diagnostic reproducibility, 60—63

Endometrial intraepithelial carcinoma (EIC),

clinical outcome prediction, 83

diagnostic criteria, 80—83

histology, 64

molecular features, 80, 81

serous carcinoma association, 63, 64

serous endometrial intraepithelial carcinoma, 86, 87

Epidermal growth factor receptor, *see* Her-2/neu

Epithelial trophoblastic tumor (ETT), pathogenesis, 163, 164

EPS, *see* Exaggerated placental site

ETT, *see* Epithelial trophoblastic tumor

Exaggerated placental site (EPS), pathogenesis, 162

**F**

Fenretinide, ovarian cancer chemoprophylaxis, 183

*FHIT*, cervical cancer marker, 117

**G**

Gestational trophoblastic disease (GTD),

classification, 157, 159, 161

trophoblastic subpopulations in placenta,

chorionic-type intermediate trophoblastic cell, 159

cytotrophoblast, 158

gene expression profiles, 160

implantation site intermediate trophoblastic cell, 159

syncytiotrophoblast, 158

villous intermediate trophoblastic cell, 158, 159

pathogenesis,

choriocarcinoma, 161, 162

epithelial trophoblastic tumor, 163, 164

exaggerated placental site, 162

placental site nodule, 163

placental site trophoblastic tumor, 162, 163

GTD, *see* Gestational trophoblastic disease

**H**

HE4/WFDC2, ovarian cancer early detection marker, 31

Her-2/neu,

cervical cancer marker, 117, 118

ovarian cancer,

amplification in ovarian carcinogenesis, 23

prognostic marker, 38

Hereditary nonpolyposis colorectal cancer syndrome (HNPCC),

cardinal features, 197



- endometrial cancer,  
 age at diagnosis, 207  
 association, 195—197, 202, 205, 211  
 clinical characteristics, 206, 207  
 multiple primary cancers, 208, 209  
 surveillance and surgical prophylaxis, 209—  
 211  
 mismatch repair gene mutations, 179, 205  
 ovarian cancer risks, 178, 179, 207, 208
- HIV, *see* Human immunodeficiency virus
- HLA-G, overexpression in ovarian carcinogenesis, 23
- HNPCC, *see* Hereditary nonpolyposis colorectal cancer syndrome
- HPV, *see* Human papillomavirus
- Human immunodeficiency virus (HIV), human papillomavirus and cervical cancer interactions, 116
- Human papillomavirus (HPV), *see also* Cervical cancer,  
 adolescent biological vulnerability, 105, 106  
 cervical cancer association evidence, 125, 126  
 clearance versus oncogenic progression, 131—133, 140  
 DNA integration into host genome, 115  
 epidemiology, 127  
 genotypes, 125, 126  
 high-risk types in cervical cancer, 127  
 human immunodeficiency virus interactions, 116  
 infection mechanism, 130, 131  
 natural history in adolescents, 106, 107  
 oncoproteins,  
 cell cycle effects, 114, 133  
 types and functions, 127—130, 140  
 prevalence by age, 104  
 sexual transmission, 103, 104, 126  
 squamous intraepithelial lesion, *see* Cervical cancer  
 structure, 127  
 vaccination,  
 prophylaxis,  
 comparison of vaccines, 139  
 L1-based vaccines, 134—136  
 L2-based vaccines, 136, 138, 140  
 rationale, 134  
 therapeutic vaccines,  
 combination approaches, 146  
 dendritic cell-based vaccines, 144, 145  
 DNA vaccines, 143, 144, 146  
 live vector-based vaccines, 140, 143, 146  
 peptide-based vaccines, 141, 142  
 prospects, 147, 148  
 RNA vaccines, 144  
 tumor cell-based vaccines, 145
- Hydatidiform mole, *see* Gestational trophoblastic disease
- I**
- Implantation site intermediate trophoblastic cell, features, 159
- K**
- Kallikreins, ovarian cancer,  
 early detection marker, 31  
 prognostic marker, 32, 33
- Keratins, cervical cancer markers, 118—119
- Ki-67, cervical cancer marker, 117
- KRAS*,  
 endometrial cancer mutations, 79, 80, 94, 95  
 ovarian carcinogenesis mutations, 20—22, 24
- L**
- Lynch syndrome, *see* Hereditary nonpolyposis colorectal cancer syndrome
- M**
- Matrix metalloproteinases (MMPs), cervical cancer markers, 119
- Medroxyprogesterone acetate, endometrial cancer management, 67
- Microsatellite instability, endometrial cancer, 78, 79, 94, 202—205
- MLH1*,  
 hereditary nonpolyposis colorectal cancer syndrome mutations, 179  
 microsatellite instability in endometrial cancer, 78, 79, 94, 202—205
- MMPs, *see* Matrix metalloproteinases
- MSH2*, hereditary nonpolyposis colorectal cancer syndrome mutations, 179
- Muc16, *see* CA 125
- N**
- Nonsteroidal anti-inflammatory drugs (NSAIDs), ovarian cancer chemoprophylaxis, 183, 184
- NSAIDs, *see* Nonsteroidal anti-inflammatory drugs
- O**
- Oral contraceptives, ovarian cancer chemoprophylaxis, 183
- Ovarian cancer,  
 classification, 17—19  
 epidemiology, 17, 169  
 heredity,  
 breast/ovarian cancer syndrome, 174—178  
 genetic susceptibility screening, 179, 180  
 hereditary nonpolyposis colorectal cancer syndrome, 178, 179, 207, 208  
 odds ratios, 169  
 markers,  
 early detection markers,  
 CA 125, 30, 31, 181  
 candidate markers, 32

- HE4/WFDC2, 31  
 importance, 29, 30  
 kallikreins, 31  
 serum proteomics, 31, 32  
 prognosis, outcome, or drug resistance markers,  
 Bax, 37  
 Bcl-2, 37  
 CA 125, 38  
 cyclin D1, 37  
 cyclin E, 37  
 Her-2/neu, 38  
 kallikreins, 32, 33  
 microarray analysis, 39  
 p16, 36  
 p21, 36  
 p27, 36  
 p53, 33—36  
 retinoblastoma protein, 37  
 survivin, 37, 38  
 prospects, 39, 40  
 prophylaxis,  
 chemoprophylaxis, 182—184  
 surgery, 184, 185  
 risk factors,  
 age, 171, 172  
 diet, 172, 173  
 environmental factors, 173  
 family history, 173, 174  
 race and ethnicity, 172  
 reproductive factors, 170, 171  
 screening, 180—182  
 serous carcinogenesis model,  
 clinicopathology, 18, 19  
 genetic alterations, 19—24  
 prospects for study, 25  
 surveillance, 182  
 survival, 17, 29
- P**  
 p16,  
 cervical cancer marker, 117  
 ovarian cancer prognostic marker, 36  
 p21, ovarian cancer prognostic marker, 36  
 p27, ovarian cancer prognostic marker, 36  
 p53,  
 angiogenesis, 119  
 cancer alterations, 8  
 cervical cancer polymorphisms, 114, 115  
 chromosomal alterations, 119, 120  
 endometrial cancer mutations,  
 type I cancer, 94  
 type II cancer, 74, 75, 85  
 human immunodeficiency virus interactions, 116  
 ovarian cancer,  
 mutations in carcinogenesis, 22, 23  
 prognostic marker, 33—36  
 Paclitaxel, endometrial cancer management, 66  
 Placental site nodule, pathogenesis, 163  
 Placental site trophoblastic tumor (PSTT), pathogenesis, 162, 163  
 Proteomics, ovarian cancer marker development, 31, 32, 40  
 PSTT, *see* Placental site trophoblastic tumor  
*PTEN*,  
 endometrial cancer type I mutations, 74, 75, 77, 78, 83, 85, 95  
 ovarian carcinogenesis mutations, 24  
 transgenic mice, 98
- R**  
 Radiation therapy, endometrial cancer management, 66  
 Rb, *see* Retinoblastoma protein  
 Retinoblastoma protein (Rb),  
 cancer alterations, 8, 9  
 ovarian cancer prognostic marker, 37
- S**  
 Serous ovarian carcinogenesis, *see* Ovarian cancer  
 Stein—Leventhal syndrome, endometrial cancer, 212  
 Survivin, ovarian cancer prognostic marker, 37, 38  
 Syncytiotrophoblast, features, 158
- T**  
 Tamoxifen, endometrial cancer management, 66  
 Trophoblastic tumor, *see* Gestational trophoblastic disease  
*TSLC1*, tumor suppressor activity, 120
- V**  
 Vaccines, *see* Human papillomavirus  
 Villous intermediate trophoblastic cell, features, 158, 159  
 Vitamin D, ovarian cancer chemoprophylaxis, 183